

# Chapter 7

## Transmission Media

---

**Figure 7.1** *Transmission medium and physical layer*

---

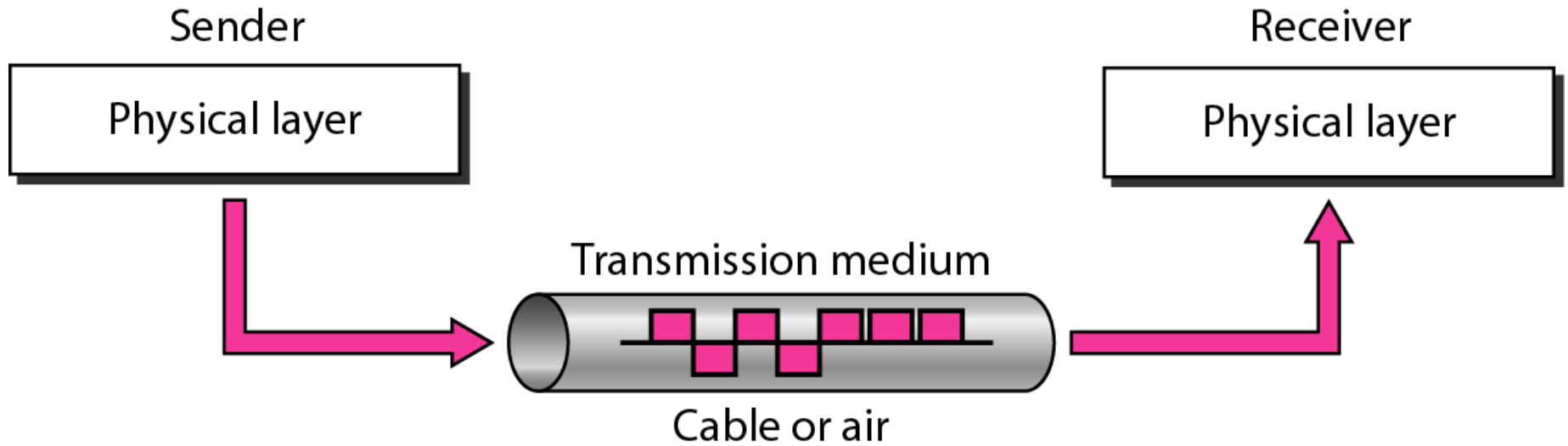

---

**Figure 7.2** *Classes of transmission media*

---

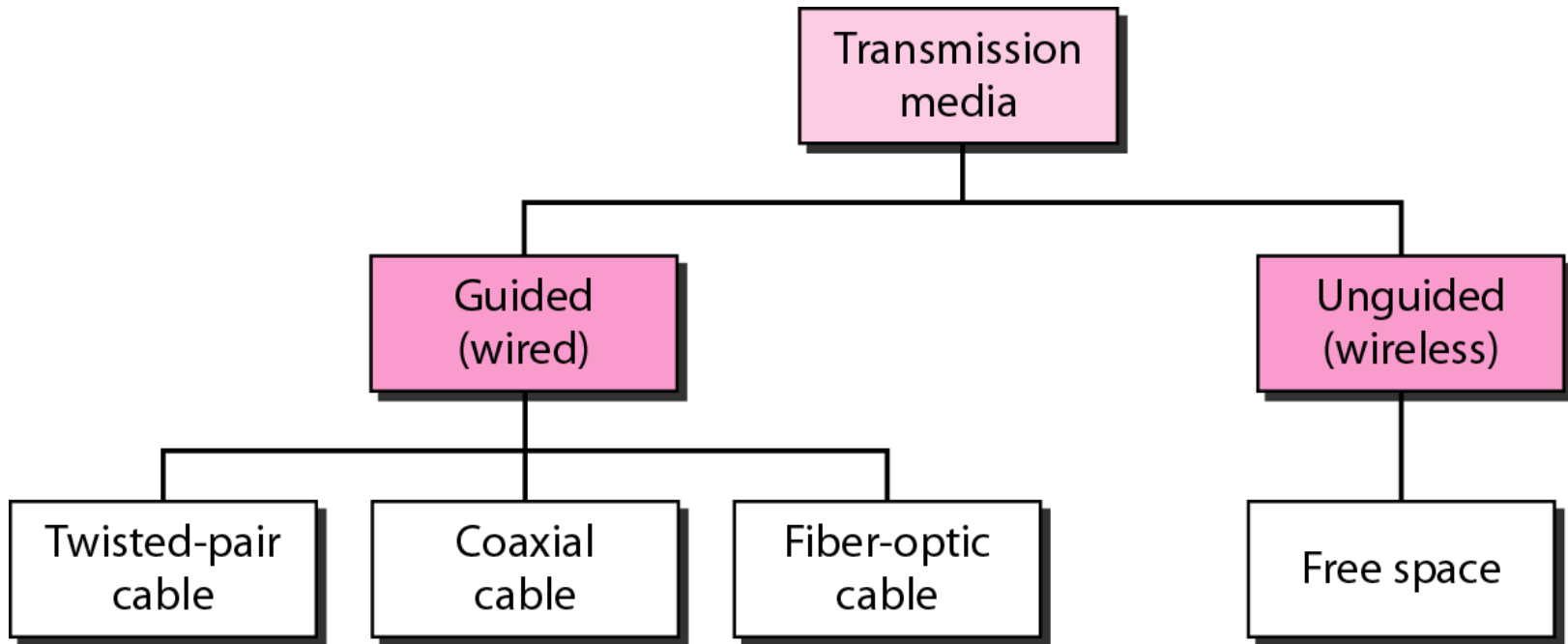

# 7-1 GUIDED MEDIA

*Guided media, which are those that provide a conduit from one device to another, include twisted-pair cable, coaxial cable, and fiber-optic cable.*

## *Topics discussed in this section:*

**Twisted-Pair Cable**

**Coaxial Cable**

**Fiber-Optic Cable**

---

**Figure 7.3** *Twisted-pair cable*

---

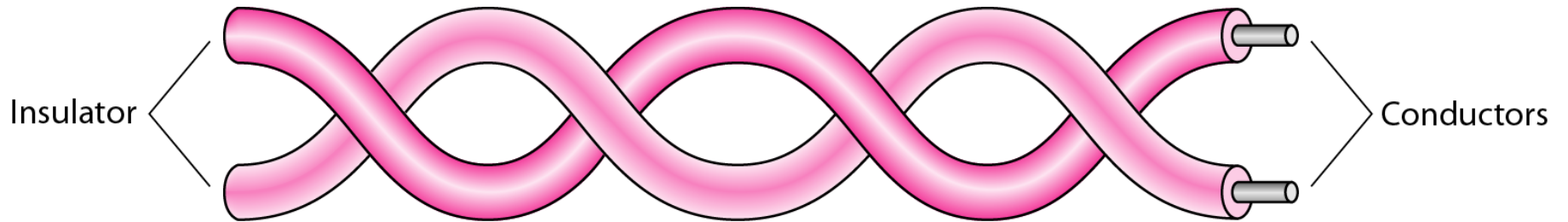

---

**Figure 7.4** *UTP and STP cables*

---

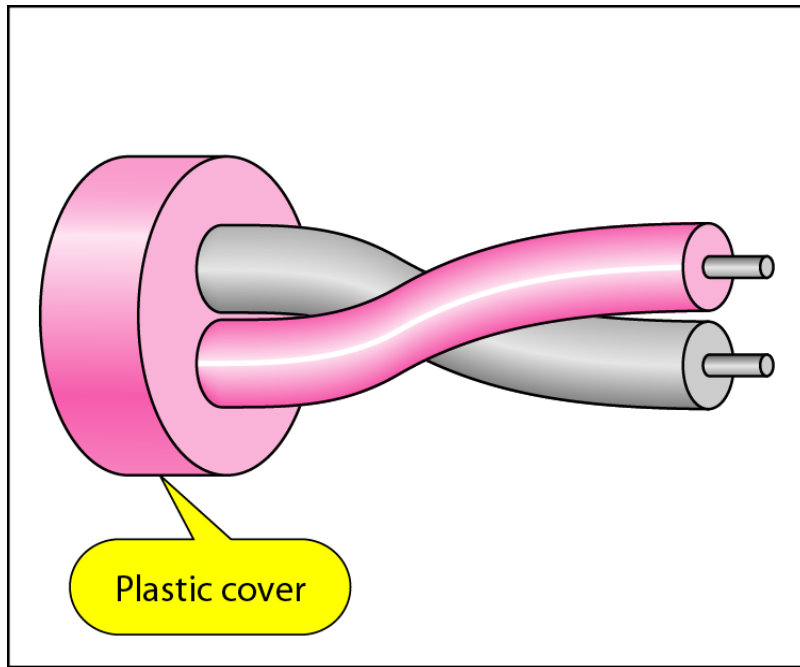

a. UTP

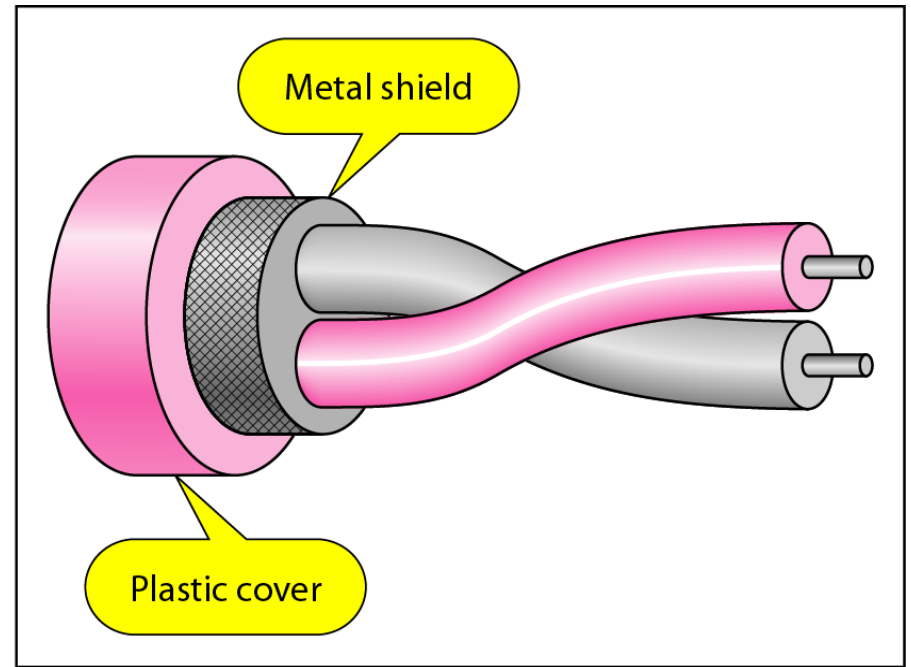

b. STP

**Table 7.1** *Categories of unshielded twisted-pair cables*

<i>Category</i>	<i>Specification</i>	<i>Data Rate (Mbps)</i>	<i>Use</i>
1	Unshielded twisted-pair used in telephone	< 0.1	Telephone
2	Unshielded twisted-pair originally used in T-lines	2	T-1 lines
3	Improved CAT 2 used in LANs	10	LANs
4	Improved CAT 3 used in Token Ring networks	20	LANs
5	Cable wire is normally 24 AWG with a jacket and outside sheath	100	LANs
5E	An extension to category 5 that includes extra features to minimize the crosstalk and electromagnetic interference	125	LANs
6	A new category with matched components coming from the same manufacturer. The cable must be tested at a 200-Mbps data rate.	200	LANs
7	Sometimes called SSTP (shielded screen twisted-pair). Each pair is individually wrapped in a helical metallic foil followed by a metallic foil shield in addition to the outside sheath. The shield decreases the effect of crosstalk and increases the data rate.	600	LANs

---

**Figure 7.5** *UTP connector*

---

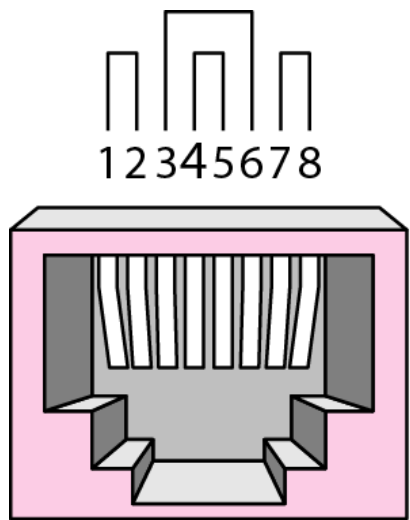

RJ-45 Female

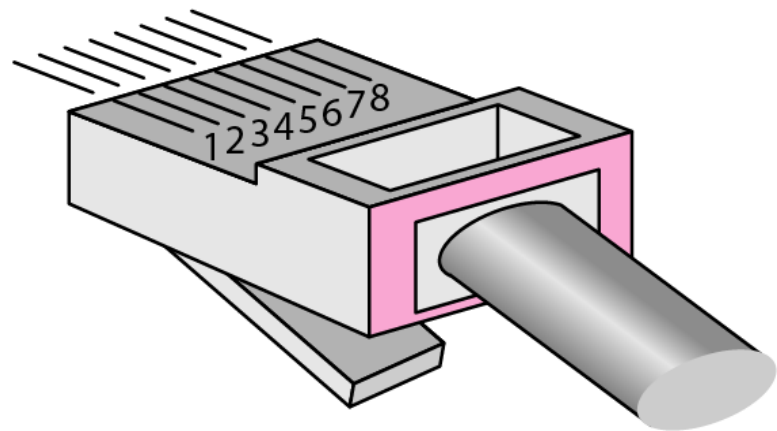

RJ-45 Male



**Figure 7.6** *UTP performance*

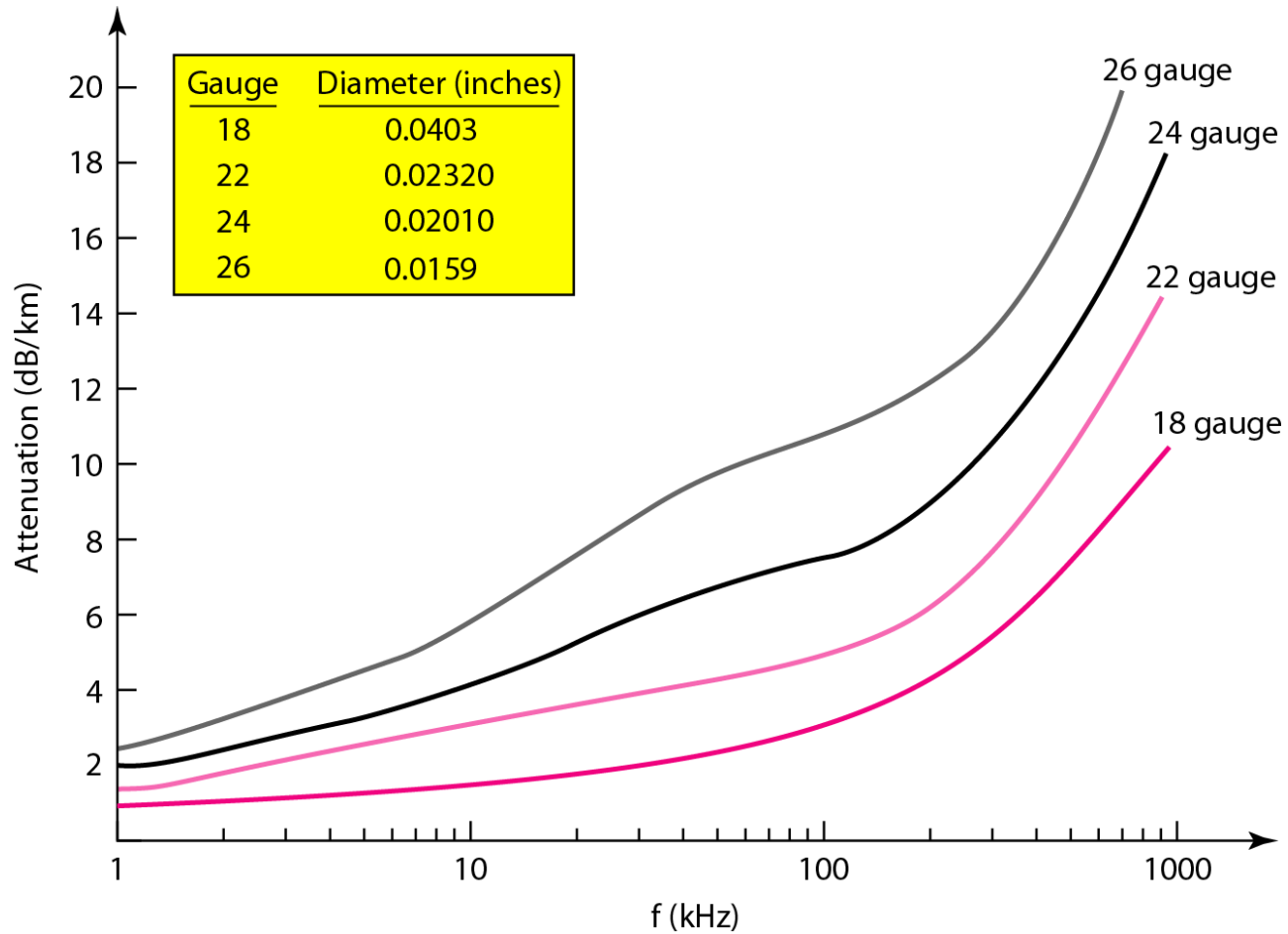

---

**Figure 7.7** *Coaxial cable*

---

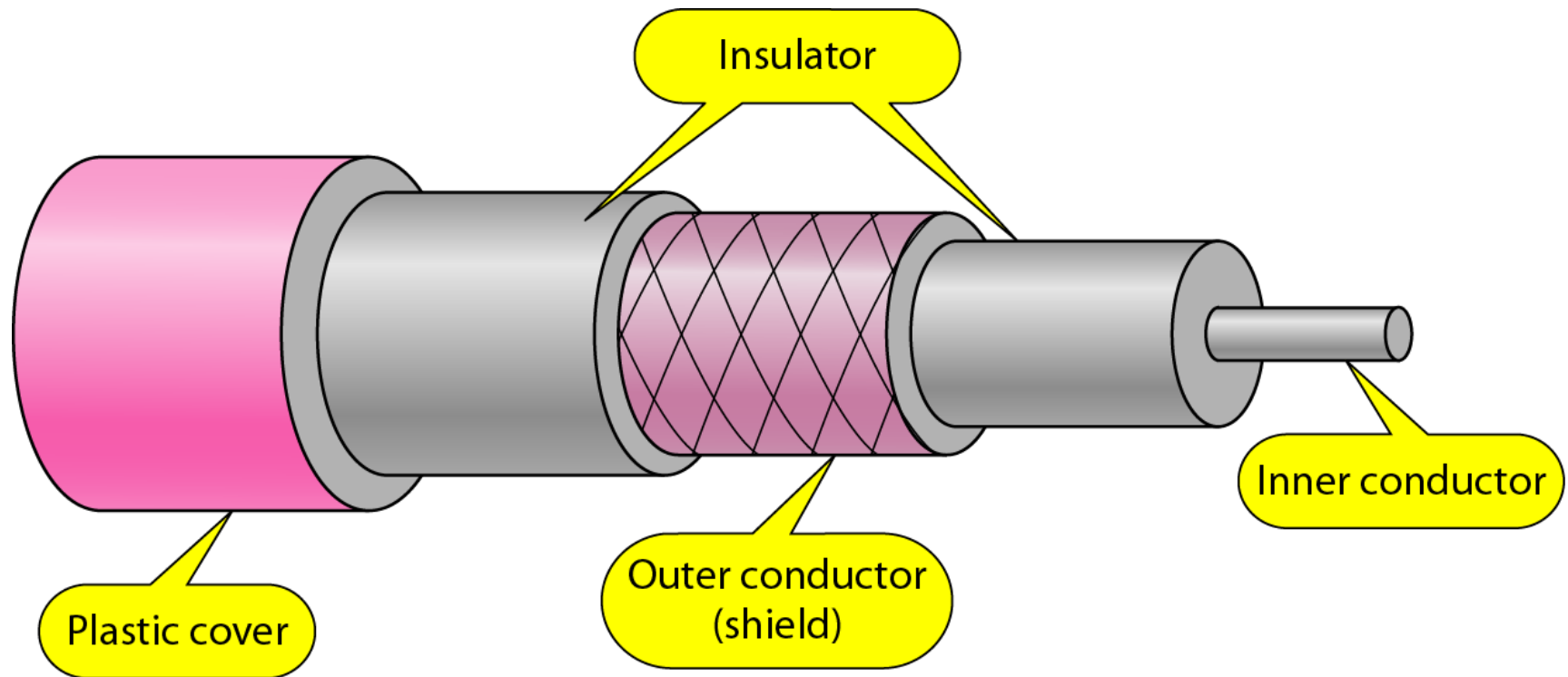

**Table 7.2** *Categories of coaxial cables*

<i>Category</i>	<i>Impedance</i>	<i>Use</i>
RG-59	75 $\Omega$	Cable TV
RG-58	50 $\Omega$	Thin Ethernet
RG-11	50 $\Omega$	Thick Ethernet

---

**Figure 7.8** *BNC connectors*

---

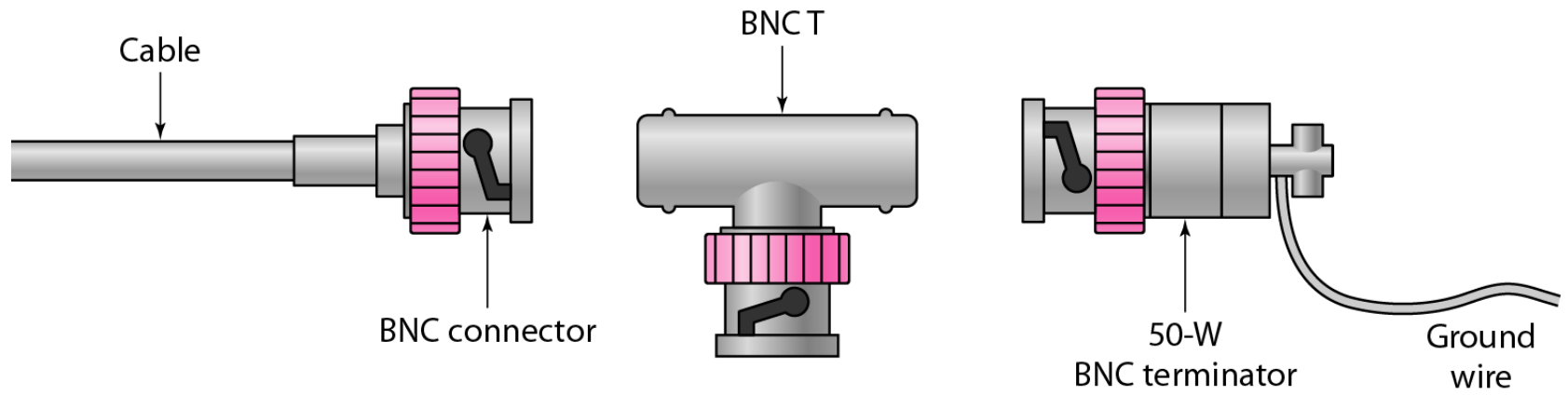

**Figure 7.9** *Coaxial cable performance*

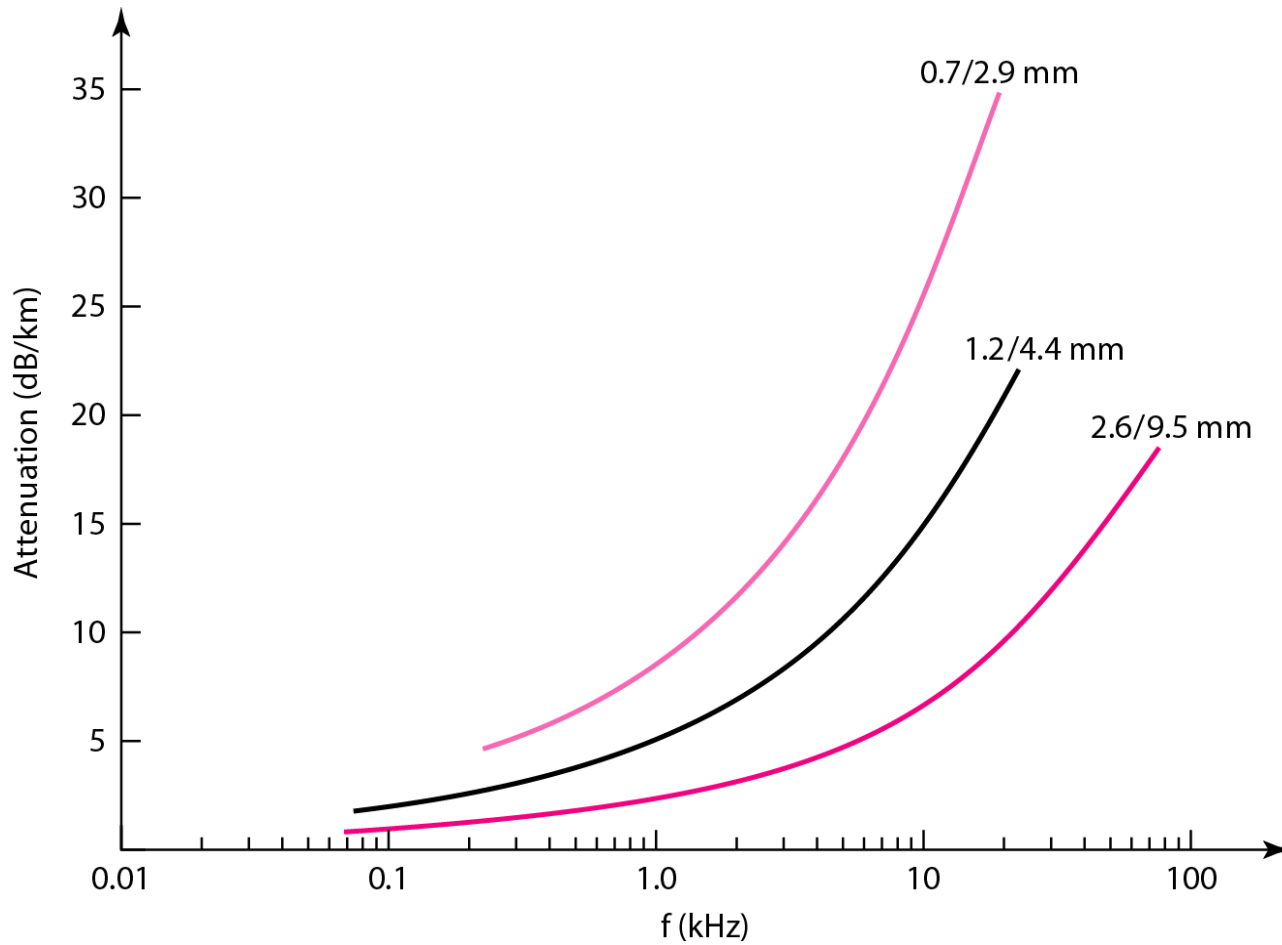

---

## Figure 7.10 Fiber optics: *Bending of light ray*

---

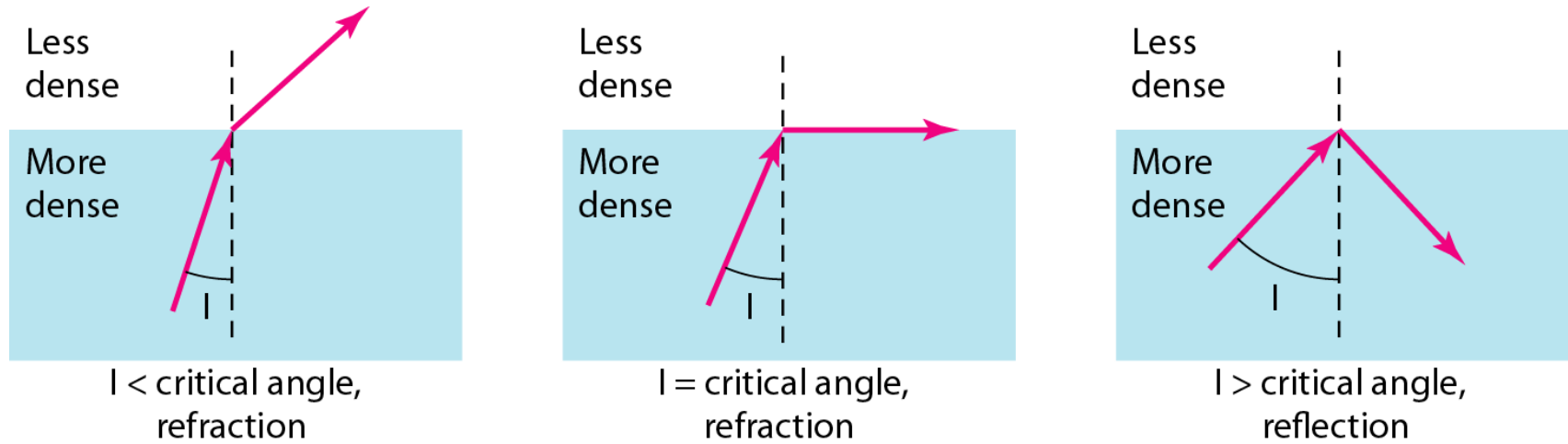

---

**Figure 7.11** *Optical fiber*

---

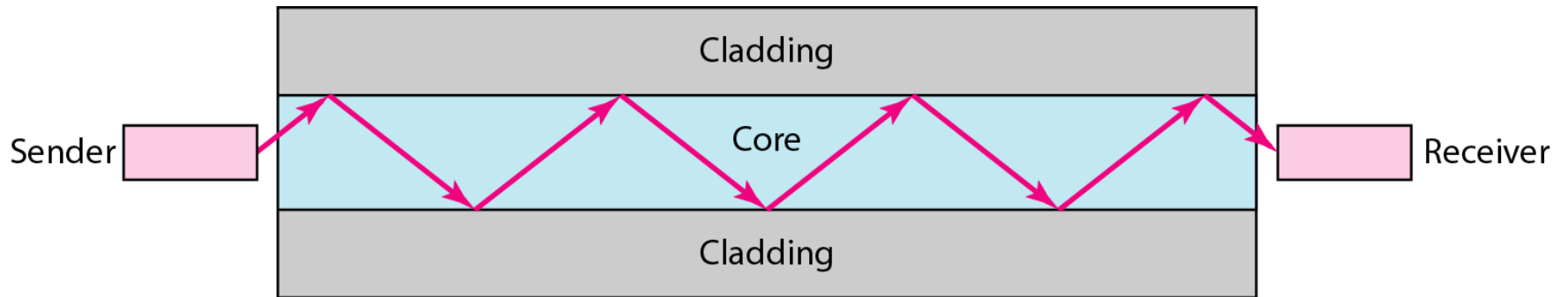

---

**Figure 7.12** *Propagation modes*

---

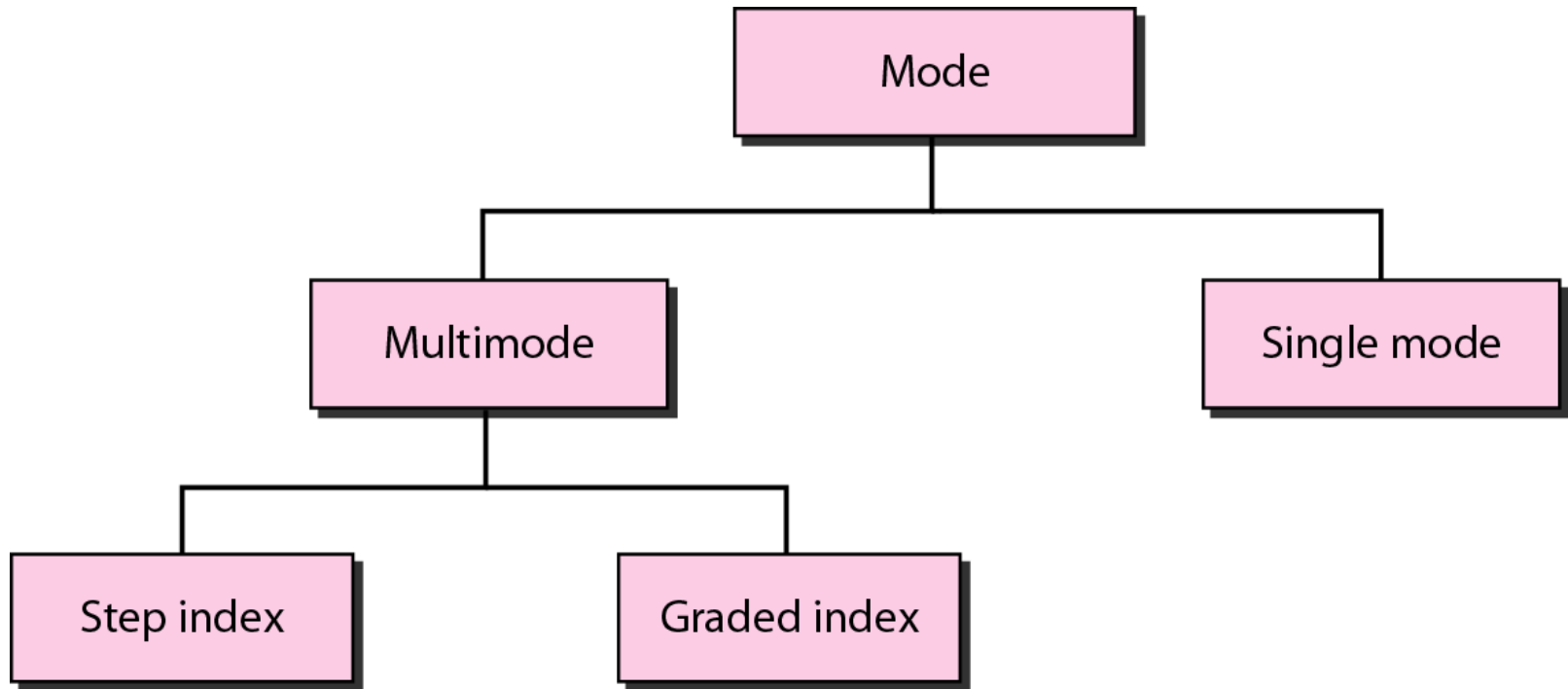



## Figure 7.13 *Modes*

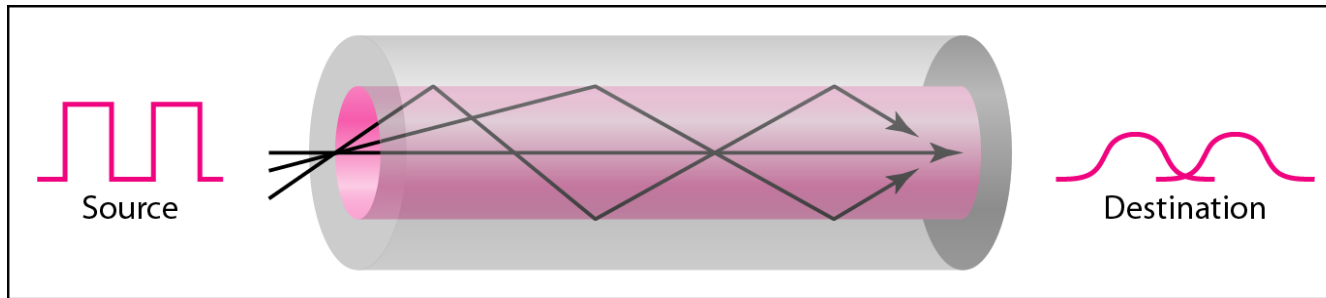

a. Multimode, step index

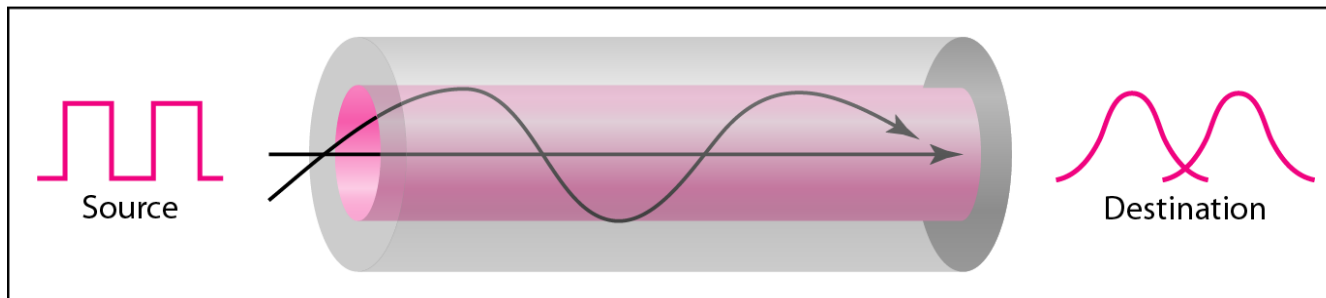

b. Multimode, graded index

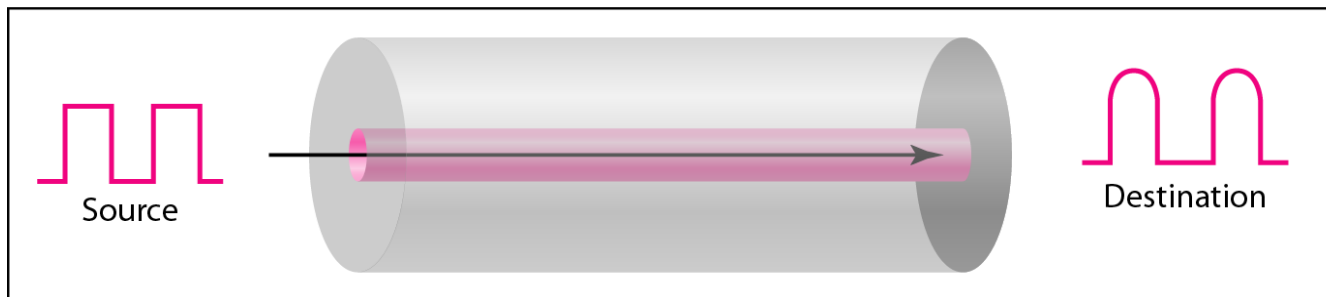

c. Single mode

**Table 7.3** *Fiber types*

<i>Type</i>	<i>Core (<math>\mu\text{m}</math>)</i>	<i>Cladding (<math>\mu\text{m}</math>)</i>	<i>Mode</i>
50/125	50.0	125	Multimode, graded index
62.5/125	62.5	125	Multimode, graded index
100/125	100.0	125	Multimode, graded index
7/125	7.0	125	Single mode

---

**Figure 7.14** *Fiber construction*

---

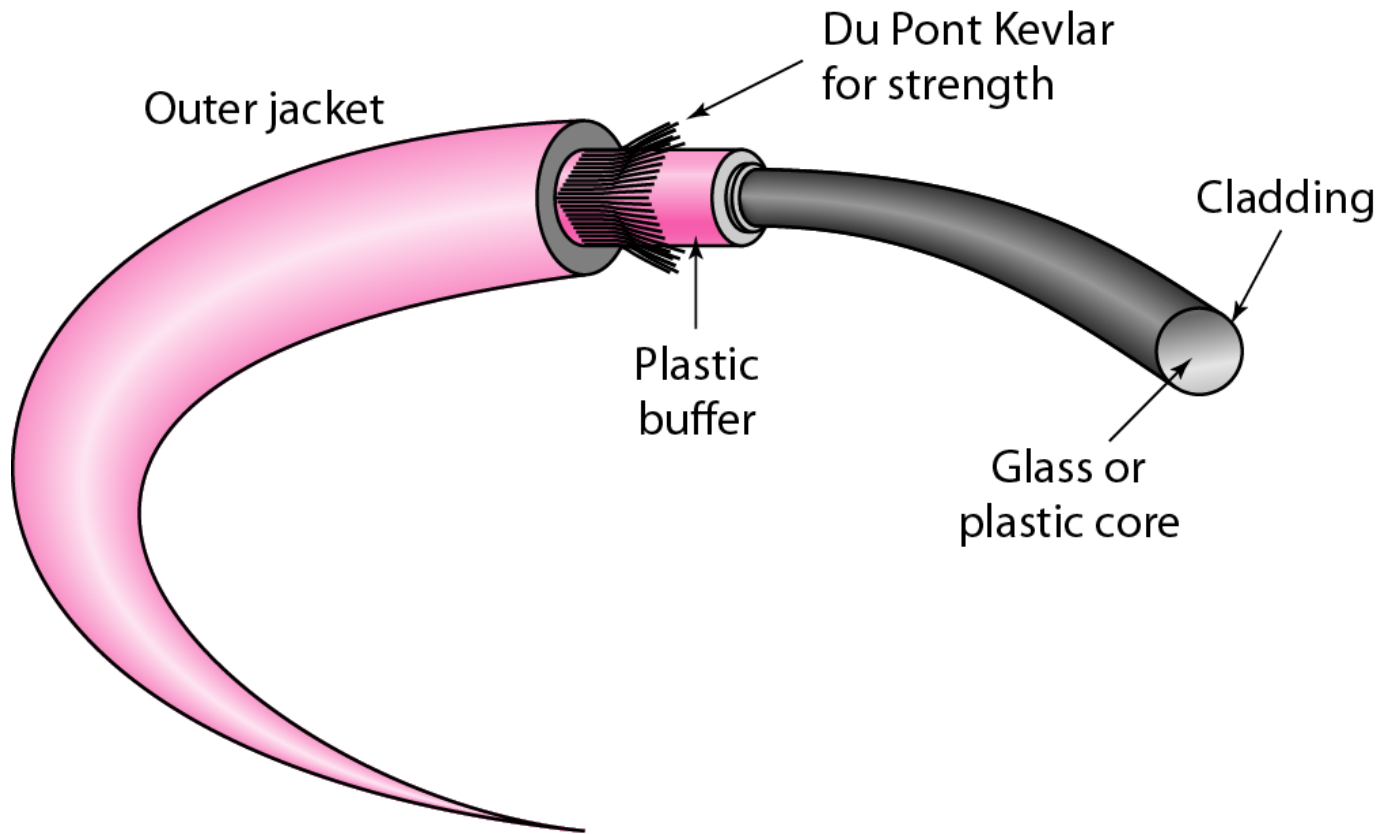

---

**Figure 7.15** *Fiber-optic cable connectors*

---

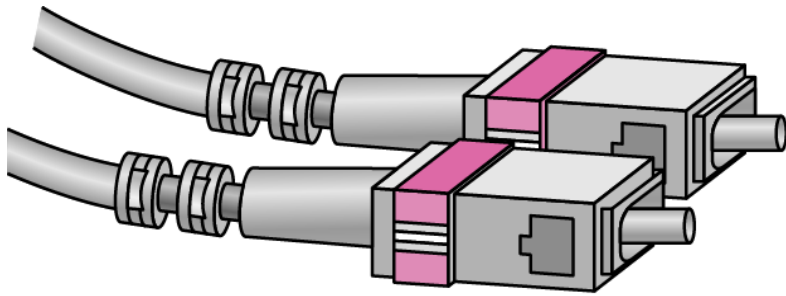

SC connector

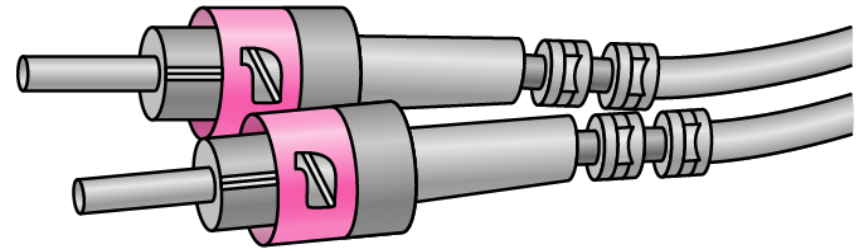

ST connector

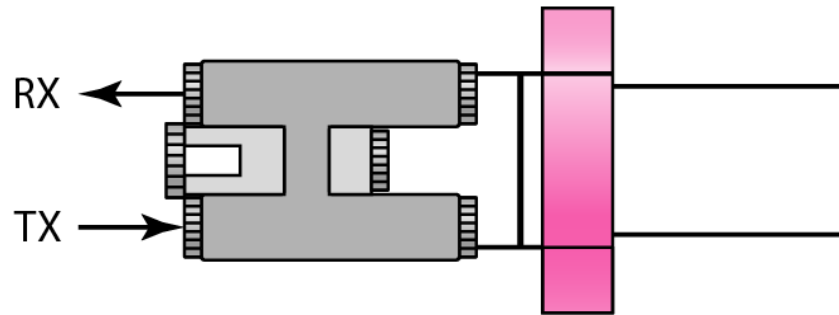

MT-RJ connector

---

**Figure 7.16** *Optical fiber performance*

---

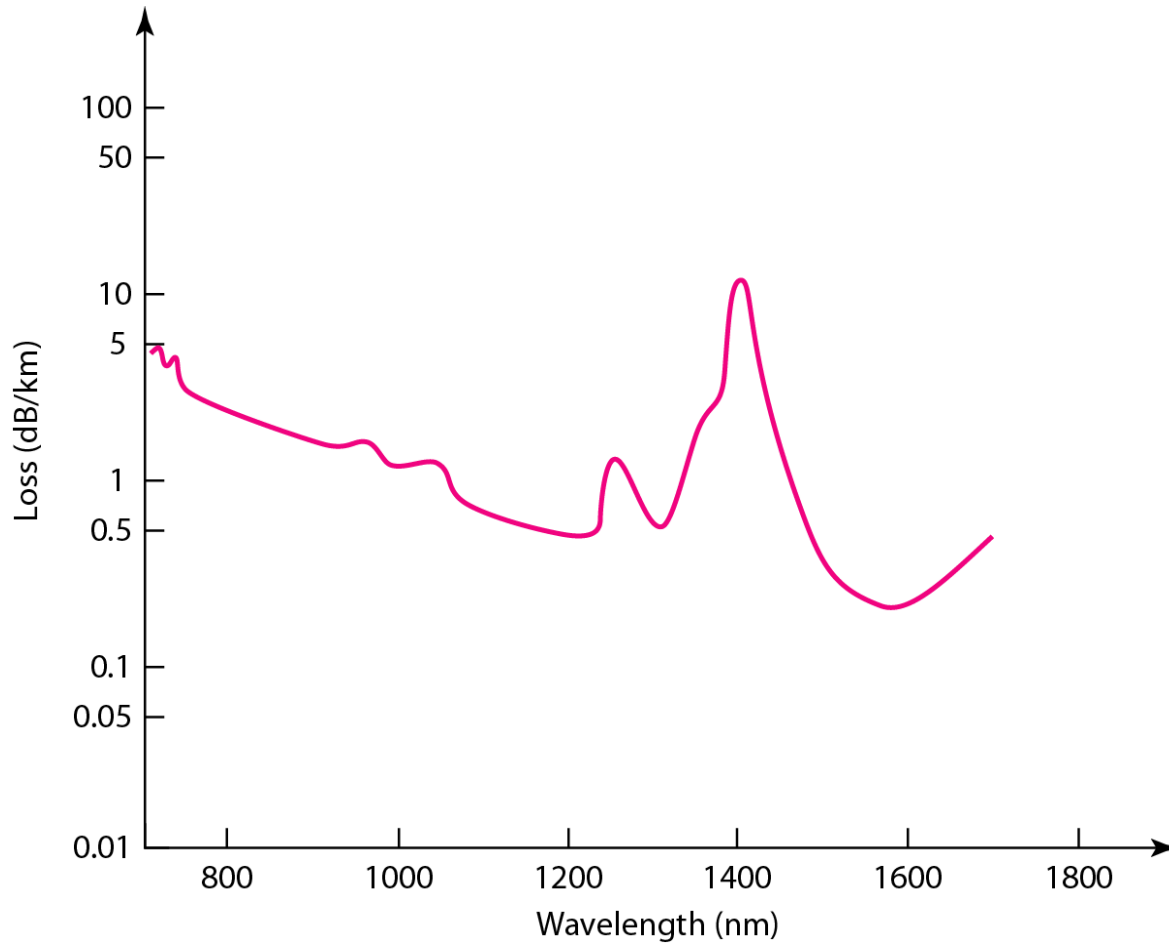

## 7-2 UNGUIDED MEDIA: WIRELESS

*Unguided media transport electromagnetic waves without using a physical conductor. This type of communication is often referred to as wireless communication.*

### *Topics discussed in this section:*

**Radio Waves**

**Microwaves**

**Infrared**

---

**Figure 7.17** *Electromagnetic spectrum for wireless communication*

---

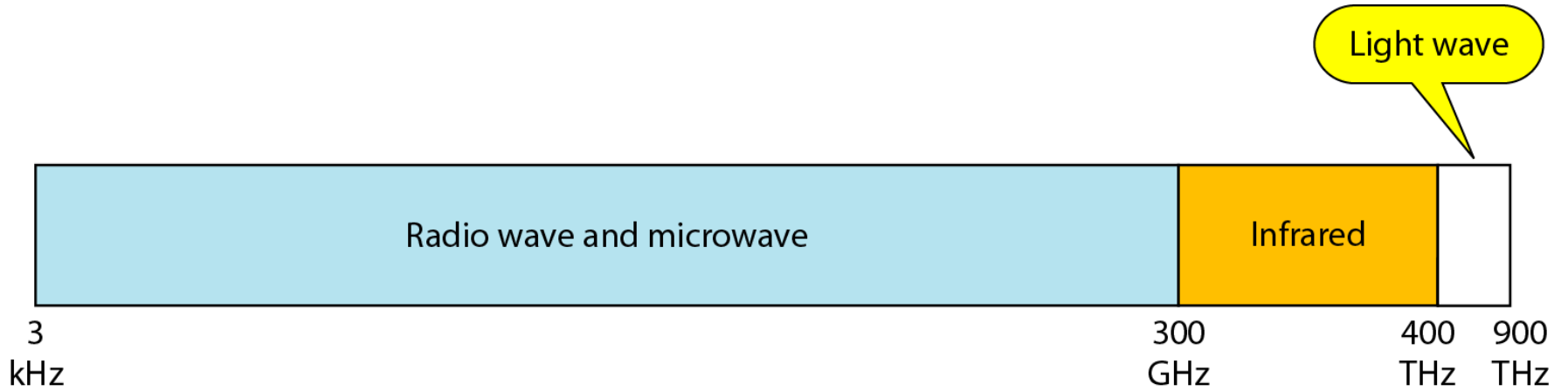

---

**Figure 7.18** *Propagation methods*

---

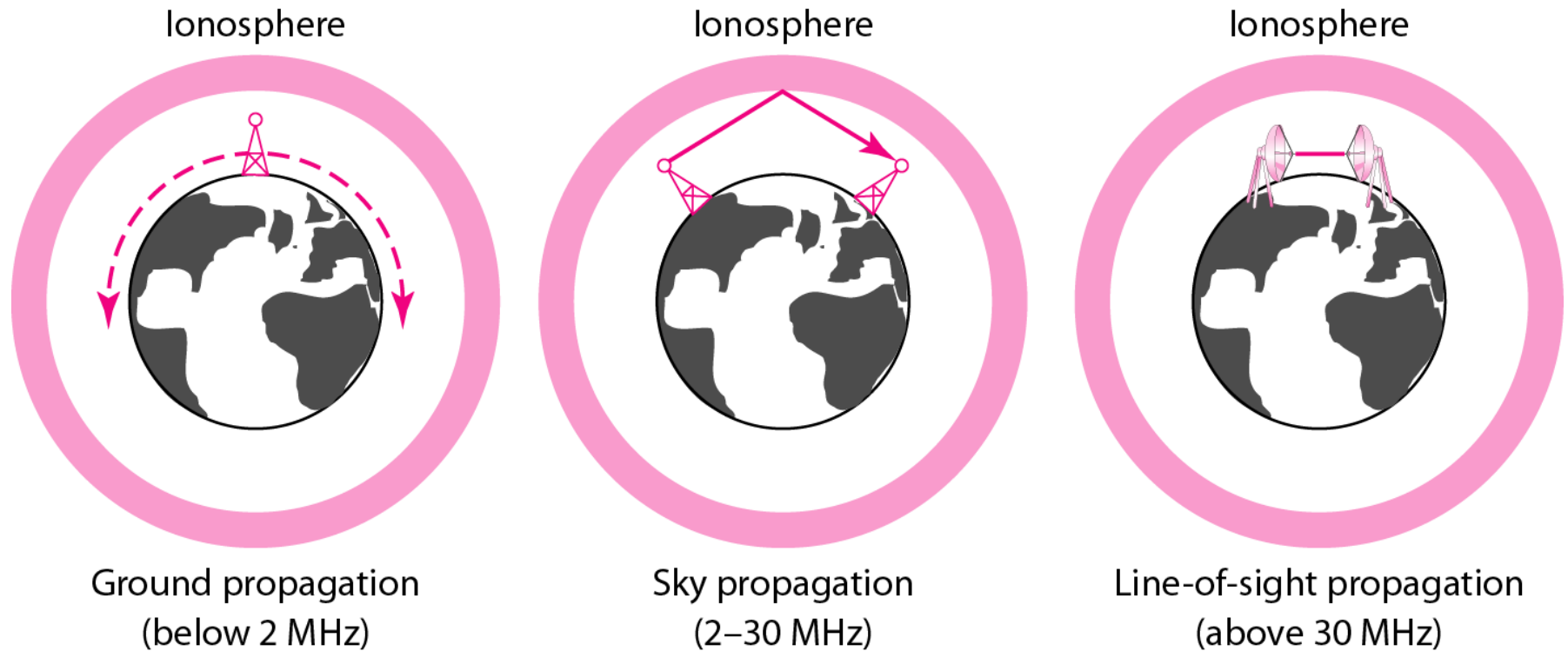



**Table 7.4 Bands**

<i>Band</i>	<i>Range</i>	<i>Propagation</i>	<i>Application</i>
VLF (very low frequency)	3–30 kHz	Ground	Long-range radio navigation
LF (low frequency)	30–300 kHz	Ground	Radio beacons and navigational locators
MF (middle frequency)	300 kHz–3 MHz	Sky	AM radio
HF (high frequency)	3–30 MHz	Sky	Citizens band (CB), ship/aircraft communication
VHF (very high frequency)	30–300 MHz	Sky and line-of-sight	VHF TV, FM radio
UHF (ultrahigh frequency)	300 MHz–3 GHz	Line-of-sight	UHF TV, cellular phones, paging, satellite
SHF (superhigh frequency)	3–30 GHz	Line-of-sight	Satellite communication
EHF (extremely high frequency)	30–300 GHz	Line-of-sight	Radar, satellite

---

**Figure 7.19** *Wireless transmission waves*

---

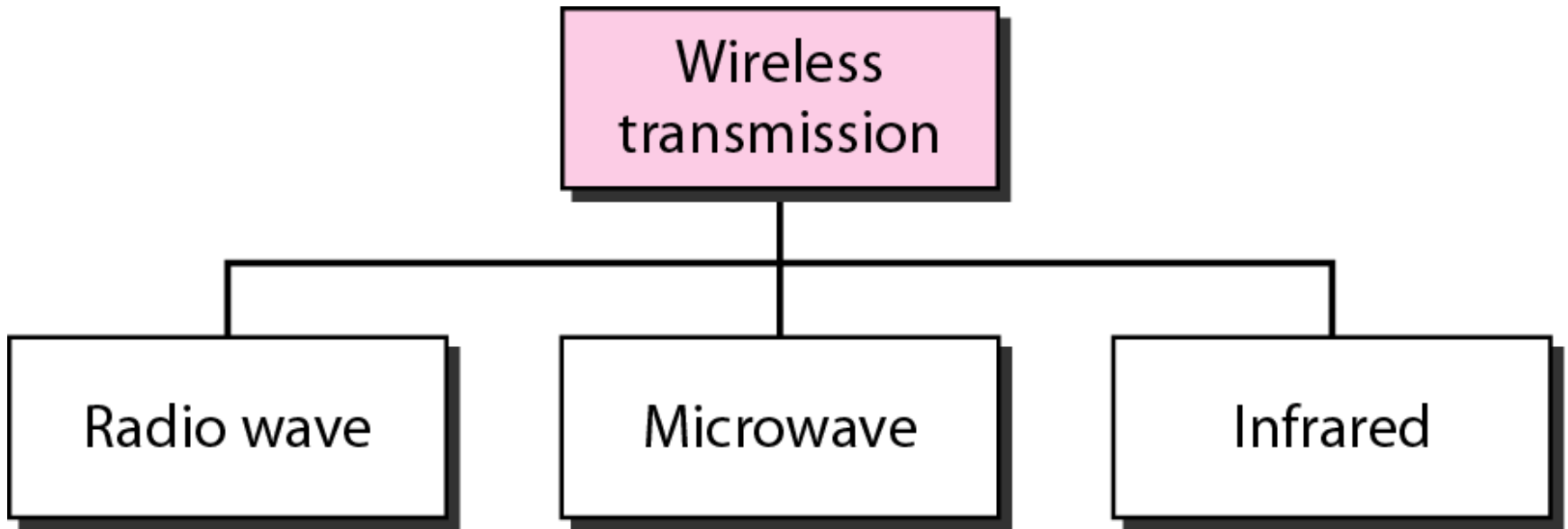



*Note*

**Radio waves are used for multicast communications, such as radio and television, and paging systems. They can penetrate through walls. Highly regulated. Use omni directional antennas**

---

**Figure 7.20** *Omnidirectional antenna*

---

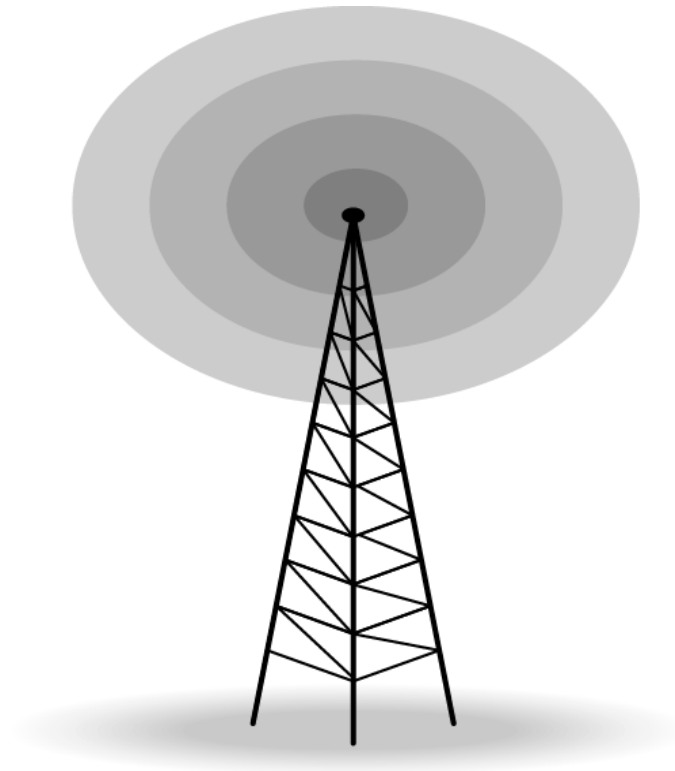



*Note*

**Microwaves are used for unicast communication such as cellular telephones, satellite networks, and wireless LANs.**

**Higher frequency ranges cannot penetrate walls.**

**Use directional antennas - point to point line of sight communications.**

---

## Figure 7.21 *Unidirectional antennas*

---

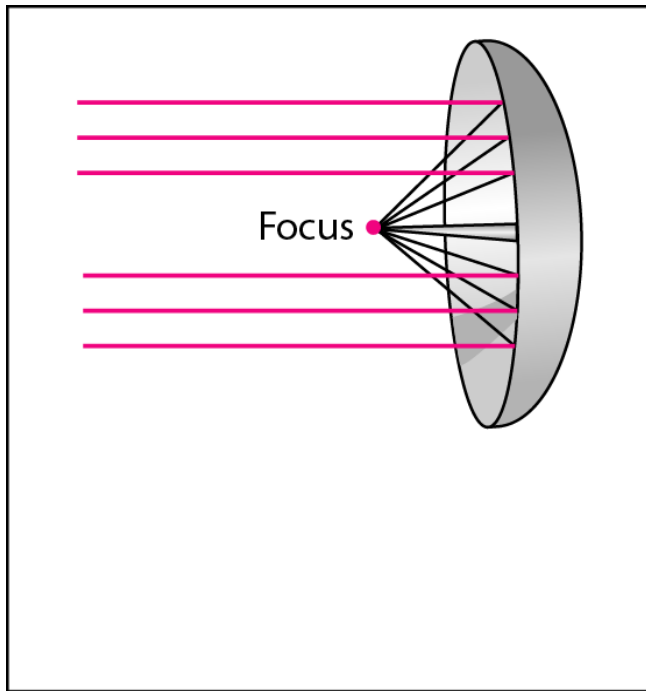

a. Dish antenna

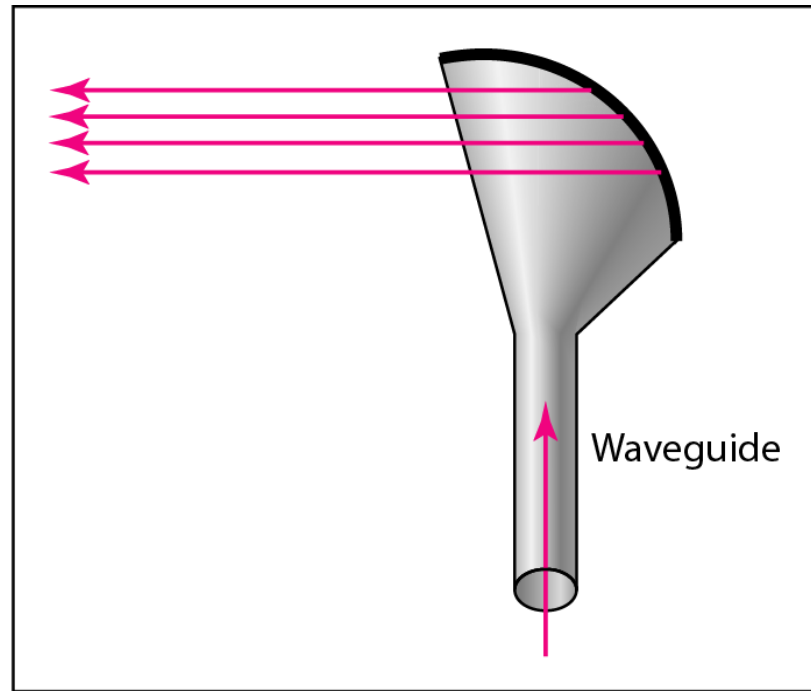

b. Horn antenna



---

*Note*

**Infrared signals can be used for short-range communication in a closed area using line-of-sight propagation.**

# Wireless Channels

- Are subject to a lot more errors than guided media channels.
- Interference is one cause for errors, can be circumvented with high SNR.
- The higher the SNR the less capacity is available for transmission due to the broadcast nature of the channel.
- Channel also subject to fading and no coverage holes.