

# Reinforced Concrete Design

# Compressive Strength of Concrete

- $f_{cr}$  is the average cylinder strength
- $f'_c$  compressive strength for design
- $f'_c$  ~2500 psi - 18,000 psi, typically 3000 - 6000 psi
- $E_c$  estimated as:  $E_c = 33w^{1.5} \sqrt{f'_c}$

where  $w$  = weight of concrete, lb/ft<sup>3</sup>

$f'_c$  in psi

$E$  in psi

for normal weight concrete ~145 lb/ft<sup>3</sup>

$$E_c = 57,000 \sqrt{f'_c}$$

# Concrete Stress-Strain Curve

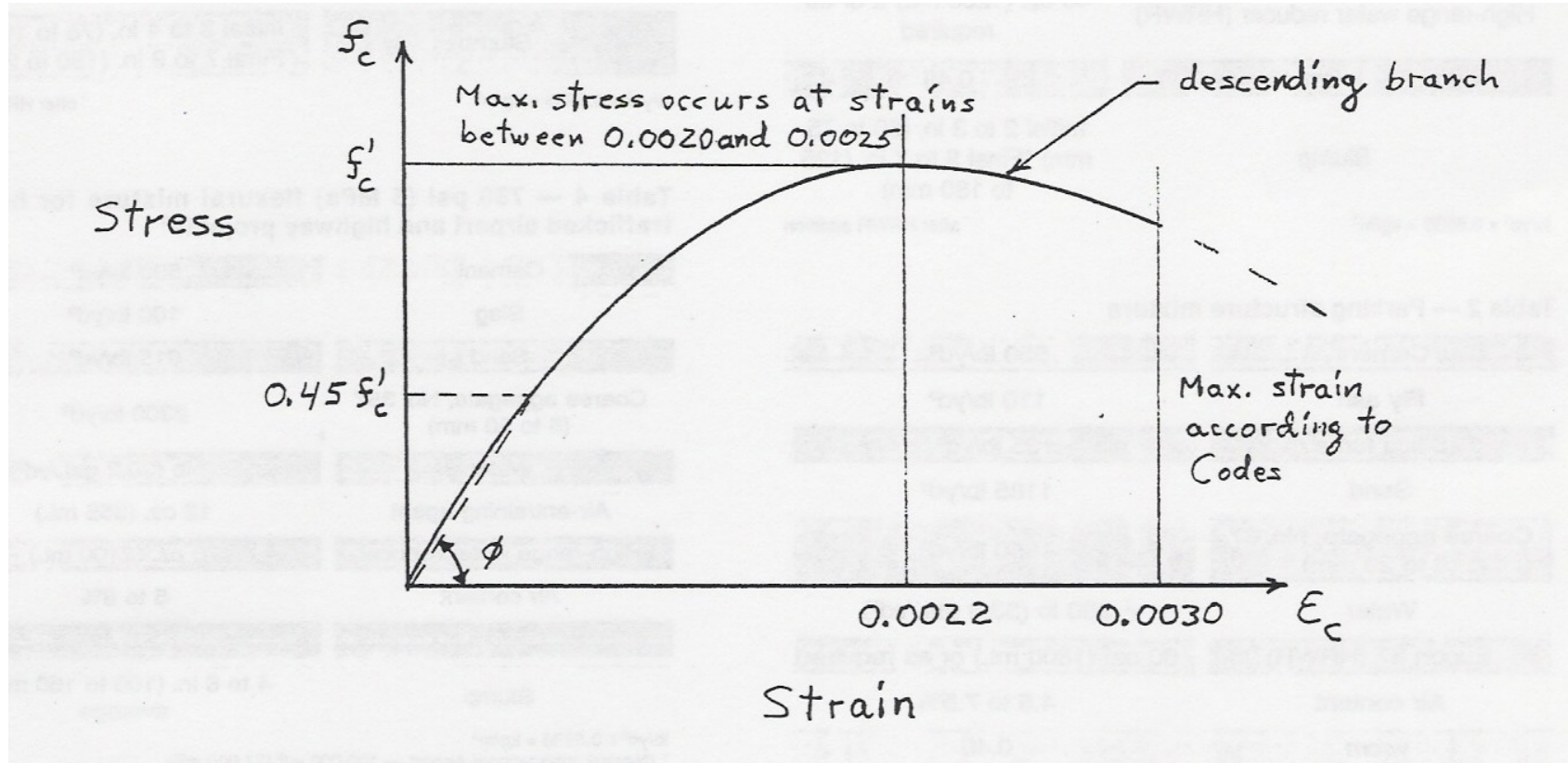

For short term loading. Over time concrete will creep and shrink.

# Concrete Strain

Strain in concrete will be caused by loading, creep, shrinkage, and temperature change.

For scale, consider a 20' section of concrete,  $f'_c = 4000$  psi, under a stress,  $f_c = 1800$  psi. Determine the change in length.

# Tensile Strength of Concrete

- Tensile strength of concrete is about  $\frac{f'_c}{10}$
- ~300 – 600 psi
- Tensile strength of concrete is ignored in design
- Steel reinforcement is placed where tensile stresses occur

Where do tensile stresses occur?

# Tensile Stresses

## Restrained shrinkage

slab on grade



shrinkage strain,  $\epsilon = 0.0006$

$$\sigma = \epsilon E = 0.0006 \times 3600 \text{ ksi} = 2.16 \text{ ksi}$$

## Flexural member

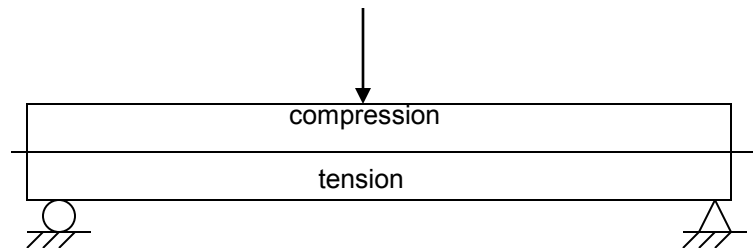

# Reinforcing Steel

- Deformed steel reinforcing bars
- Welded wire fabric
- 7-strand wire (for pre-stressing)

# Deformed Steel Reinforcing Bars Rebar

- Grade 60 (most common in US)
- Sizes #3 → #18 (number indicates diameter in  $\frac{1}{8}$  inch)

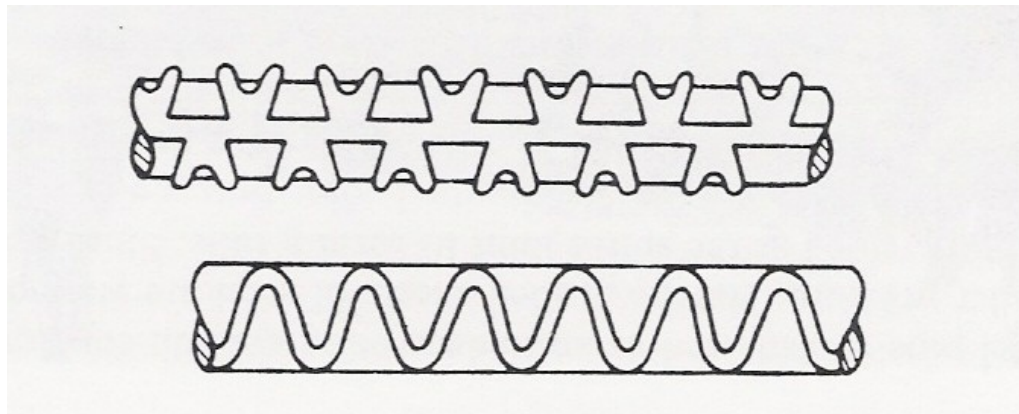



# Welded Wire Fabric

Readily available fabrics

		$\text{mm}^2/\text{m}$			$\text{mm}^2/\text{m}$ of slab width
6 x 6	- W1.4 x W1.4	59	4 x 4	- W1.4 x W1.4	90
	W2.0 x W2.0	85		W2.0 x W2.0	127
	W2.9 x W2.9	123		W2.9 x W2.9	184
	W4.0 x W4.0	169		W4.0 x W4.0	254
	W5.5 x W5.5	233			

... is available in large and small quantities. Others may be

Designation:

longitudinal wire spacing x transverse wire spacing –

cross-sectional areas of longitudinal wire x transverse wires in  
hundredths of  $\text{in}^2$

# Stress-Strain Curve, Steel and Concrete

$f_y = 60 \text{ ksi (414 MPa)}$   
 $f_u = \frac{4}{3} \text{ to } \frac{5}{3}$   
of  $f_y$   
 $\epsilon_y = 0.002$

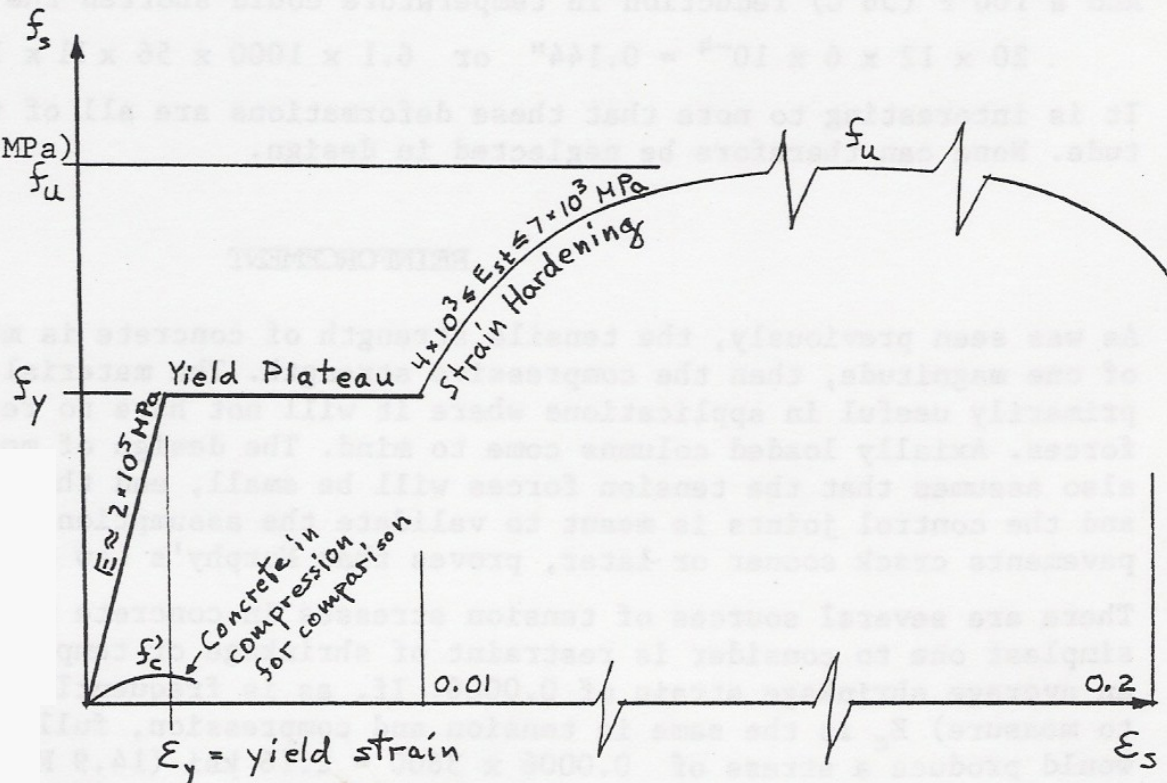

# Reinforce Concrete Design

Two codes for reinforced concrete design:

- ACI 318 Building Code Requirements for Structural Concrete
- AASHTO Specifications for Highway Bridges

We will design according to ACI 318 which is an 'LRFD' design. Load and resistance factors for ACI 318 are given on page 7, notes.

# Short Reinforced Concrete Compression Members

- Short - slenderness does not need to be considered – column will not buckle
- Only axial load

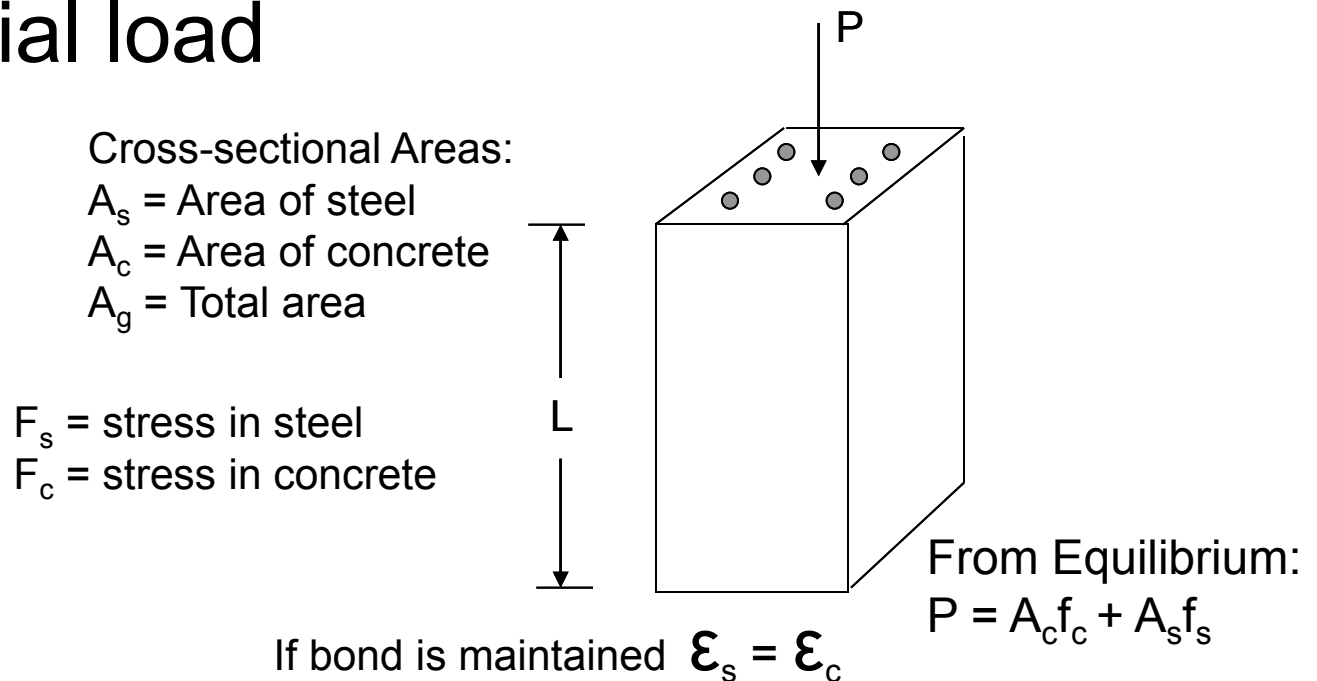

# Short Concrete Columns

For ductile failure – must assure that steel reinforcement will yield before concrete crushes.

- Strain in steel at yield  $\sim 0.002$
- $\epsilon = 0.002$  corresponds to max. stress in concrete.
- Concrete crushes at a strain  $\sim 0.003$

$$\text{Equilibrium at failure: } P = A_s F_y + A_c f'_c$$

# Reinforcement Ratio

- $\rho = A_s/A_g$
- ACI 318 limits on  $\rho$  for columns:  
 $0.01 \leq \rho \leq 0.08$  (practical  $\rho_{\max} = 0.06$ )
- Substitute  $\rho = A_s/A_g$  and  $A_g = A_s + A_c$  into equilibrium equation:  
$$P = A_g[\rho f_y + f'_c(1 - \rho)]$$

# Short Concrete Columns

$$P = A_g[\rho f_y + f'_c(1 - \rho)]$$

## Safety Factors

- Resistance factor,  $\Phi = 0.65$  (tied),  $\Phi = 0.70$  (spiral)
- When  $f_c > 0.85f'_c$ , over time, concrete will collapse
- Stray moment factor for columns,  $K_1$ 
  - $K_1 = 0.80$  for tied reinforcement
  - $K_1 = 0.85$  for spiral reinforcement

$$\Phi P_n = \Phi K_1 A_g[\rho f_y + 0.85f'_c(1 - \rho)]$$

# Short Column Design Equation

$$\Phi P_n = \Phi K_1 A_g [\rho f_y + 0.85 f'_c (1 - \rho)]$$

for design,  $P_u \leq \Phi P_n$

$$\rho \geq \frac{1}{(f_y - 0.85 f'_c)} \left[ \frac{P_u}{\Phi K_1 A_g} - 0.85 f'_c \right]$$

$$A_g \geq \frac{P_u}{\Phi K_1 [\rho f_y + 0.85 f'_c (1 - \rho)]}$$



# Transverse Reinforcement

Used to resist bulge of concrete and buckling of steel

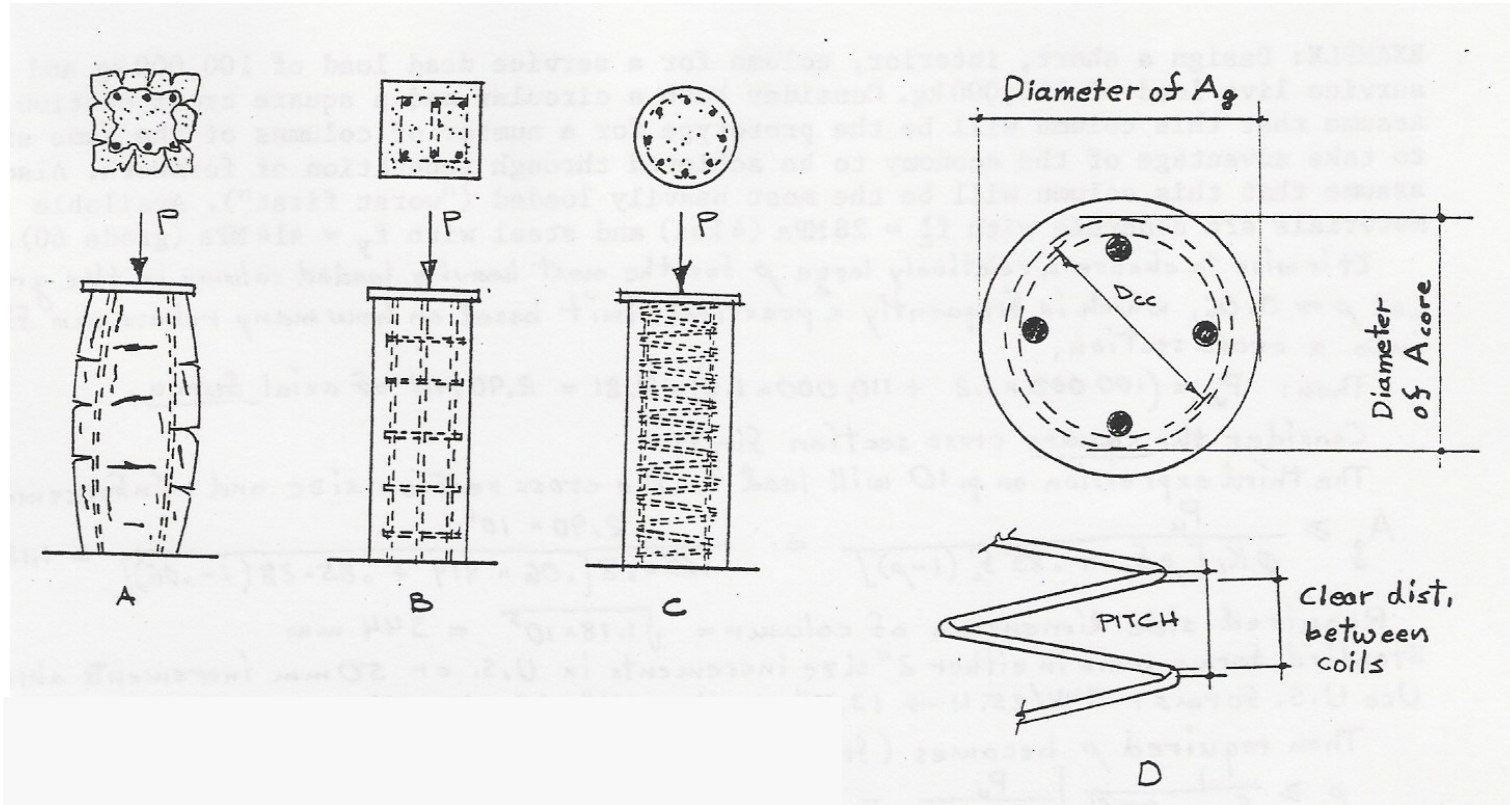

# Concrete Cover

Used to protect steel reinforcement and provide bond between steel and concrete

- $\frac{3}{4}$ " (20 mm) for interior slabs, pan joists, and other light floor systems, protected against deleterious substances;
- $1\frac{1}{2}$ " (40 mm) for most interior exposures, including main members;
- 2" (50 mm) for normal exterior exposures, with additional cover recommended for particularly aggressive environments;
- 3" (75 mm) for concrete cast against earth.

# Short Concrete Column Example

Design a short, interior, column for a service dead load of 220 kips and a service live load of 243 kips. Consider both a circular and a square cross section. Assume that this column will be the prototype for a number of columns of the same size to take advantage of the economy to be achieved through repetition of formwork. Also assume that this column will be the most heavily loaded (“worst first”). Available materials are concrete with  $f'_c = 4$  ksi and grade 60 steel.

# Available Steel Reinforcing Bars

ASTM standard reinforcing bars				
Bar size, designation	Weight, lb/ft	Nominal dimensions—Round sections		
		Diameter, in.	Cross-sectional area, in. <sup>2</sup> (mm <sup>2</sup> )	Perimeter, in.
*3 (10)	0.376	0.375	0.11 (71)	1.178
*4 (13)	0.668	0.500	0.20 (127)	1.571
*5 (16)	1.043	0.625	0.31 (198)	1.963
*6 (19)	1.502	0.750	0.44 (285)	2.356
*7 (22)	2.044	0.875	0.60 (388)	2.749
*8 (25)	2.670	1.000	0.79 (507)	3.142
*9 (29)	3.400	1.128	1.00 (645)	3.544
*10 (32)	4.303	1.270	1.27 (817)	3.990
*11 (36)	5.313	1.410	1.56 (1010)	4.430
*14 (43)	7.65	1.693	2.25 (1450)	5.32
*18 (57)	13.60	2.257	4.00 (2580)	7.09

**ACI 318. MAXIMUM NUMBER OF BARS THAT CAN BE ACCOMMODATED IN A COLUMN FACE, USING BEARING SPLICES OR RADIAL LAP SPLICES**

Column side dimension, in.	#3 ties, 1½ in. cover					#4 ties, 1½ in. cover		
	#6	#7	#8	#9	#10	#11	#14	#18
10	3	3	3	2	2	2	—	—
12	4	4	3	3	3	2	2	—
14	5	4	4	4	3	3	2	—
16	6	5	5	4	4	4	3	2
18	7	6	6	5	5	4	3	3
20	—	7	7	6	5	5	4	3
22	—	—	7	7	6	5	4	3
24	—	—	8	7	6	6	5	4
26	—	—	—	8	7	6	5	4
28	—	—	—	9	8	7	6	4
30	—	—	—	—	8	7	6	5
32	—	—	—	—	9	8	7	5
34	—	—	—	—	10	9	7	5
36	—	—	—	—	10	9	8	6
38	—	—	—	—	11	10	8	6
40	—	—	—	—	12	10	9	7
42	—	—	—	—	12	11	9	7
44	—	—	—	—	13	11	10	7
46	—	—	—	—	13	12	10	8
48	—	—	—	—	14	13	11	8
50	—	—	—	—	15	13	11	8

\* Does not include allowance for increased diameter at couplers.

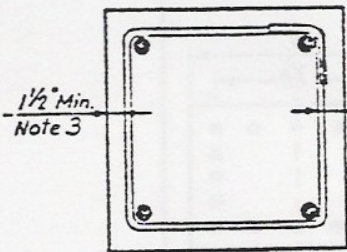

4-BARS

Vert. Bars  
Min. Cover  
= 1 Bar Dia.  
Note 3

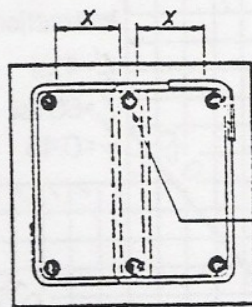

6-BARS

Note 1

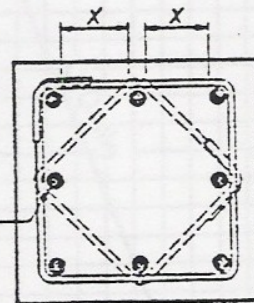

8-BARS

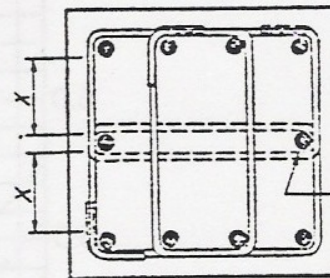

10-BARS

Note 1

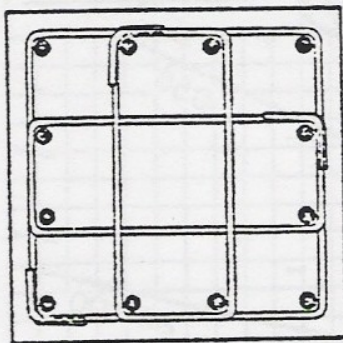

12-BARS

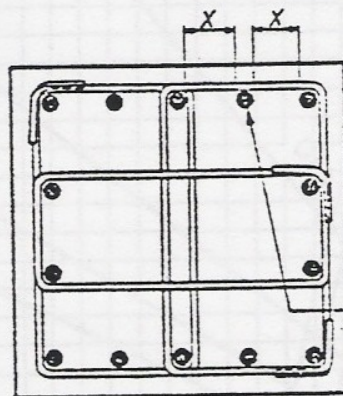

14-BARS

Note 2

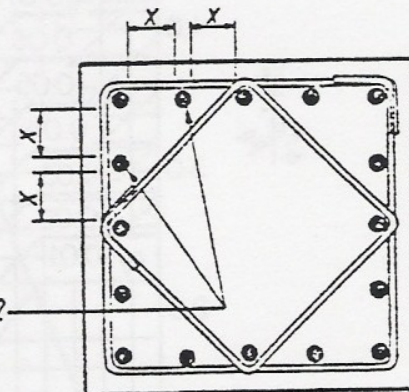

16-BARS

MAXIMUM SPACING OF COLUMN TIES\*

Vertical bar size	Size and spacing of ties, in.		
	#3	#4	#5
#5	10	—	—
#6	12	—	—
#7	14	—	—
#8	16	16	—
#9	18	18	—
#10	18	20	—
#11	†	22	22
#14	†	24	27
#18	†	24	30

\*Maximum spacing not to exceed least column dimension.  
 †#3 ties not permitted.

Minimum diameters to which standard spirals can be formed and minimum diameters which are considered collapsible are shown below for various sizes of spiral bars. *Add 3" or more to find Least dia. of col.*

Spiral bar diameter, in.	Minimum outside diameter which can be formed, in.	Minimum outside diameter of collapsible spiral, in.
3/8	9	14
1/2	12	18
5/8	15	24
3/4 (special)	30	—

clear spacing between spiral turns should not exceed 3 in. or be less than 1 in. or 1-1/3 times the maximum size of coarse aggregate used.

## MAXIMUM NUMBER OF BARS PERMITTED IN ROUND COLUMNS

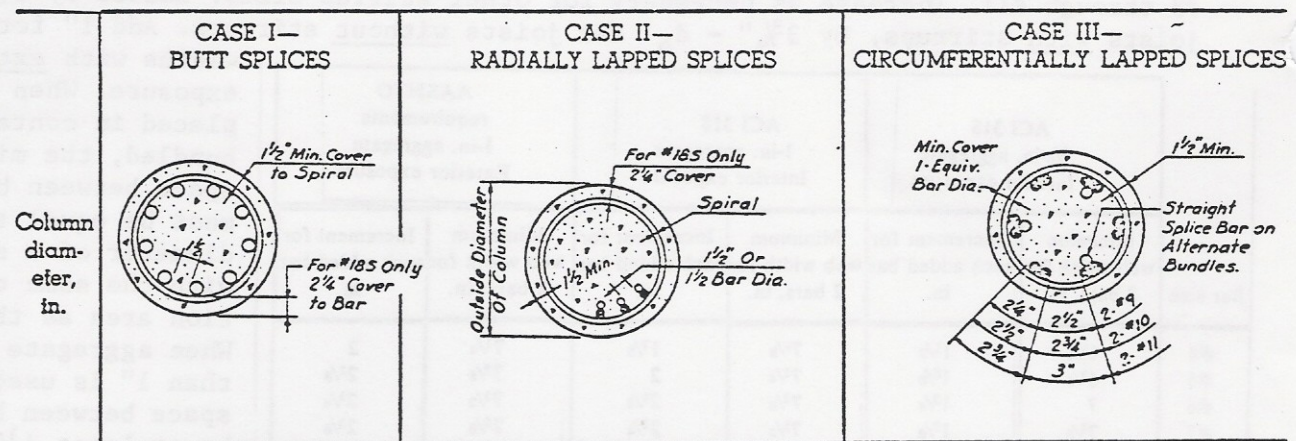

Column diameter, in.	CASE I— BUTT SPLICES						CASE II— RADIALLY LAPPED SPLICES								CASE III— CIRCUMFERENTIALLY LAPPED SPLICES									
	Bar Size						Bar Size								Bar Size									
	# 8	# 9	# 10	# 11	# 14S	# 18S	# 5	# 6	# 7	# 8	# 9	# 10	# 11	# 14S	# 18S	# 5	# 6	# 7	# 8	# 9	# 10	# 11	# 14S	# 18S
10†	6	-	-	-	-	-	6	-	-	-	-	-	-	-	-	6	6	-	-	-	-	-	-	-
11†	7	6	-	-	-	-	8	7	6	-	-	-	-	-	-	7	7	6	-	-	-	-	-	-
12†	9	7	6	-	-	-	9	8	7	6	-	-	-	-	-	8	7	7	6	-	-	-	-	-
13†	10	9	7	6	-	-	10	9	8	7	6	-	-	-	-	9	8	8	7	6	-	-	-	-
14	11	10	8	7	-	-	12	11	10	9	7	6	-	-	-	11	9	9	8	7	6	-	-	-
15	12	11	9	8	6	-	13	12	11	10	8	7	6	-	-	12	11	10	9	8	7	6	-	-
16	14	12	10	9	7	-	15	13	12	11	9	8	6	-	-	13	12	11	10	8	7	6	-	-
17	15	13	11	10	8	-	16	15	14	12	11	9	7	6	-	14	13	11	11	9	8	7	6	-
18	16	14	12	11	9	-	18	16	15	14	12	10	8	6	-	15	14	12	11	10	9	8	6	-
19	17	15	13	12	10	-	19	18	16	15	13	11	9	7	-	16	15	13	12	11	9	8	7	-
20	19	16	14	13	10	6§	21	19	18	16	14	12	10	8	-	17	16	14	13	12	10	9	7	-
21	20	18	15	14	11	7§	22	20	19	17	15	13	11	8	-	18	17	15	14	12	11	10	8	-
22	21	19	16	15	12	7§	23	22	20	18	16	14	11	9	-	20	18	16	15	13	12	10	8	6
23	22	20	17	15	13	8§	25	23	21	20	17	15	12	10	6	21	19	17	16	14	12	11	9	6
24	24	21	18	16	13	9§	26	24	22	21	18	16	13	11	7	22	20	18	17	15	13	11	9	6
25	25	22	19	17	14	9§	28	26	24	22	19	17	14	11	7	23	21	19	18	16	14	12	10	7
26	26	23	20	18	15	10	29	27	25	23	20	18	15	12	8	24	22	20	19	16	14	13	10	7
27	28	24	21	19	16	11	31	28	26	25	21	19	16	13	8	25	23	21	20	17	15	13	11	8
28	29	25	22	20	16	11	32	30	28	26	22	20	17	13	9	26	24	22	20	18	16	14	11	8
29	30	26	23	21	17	12	33	31	29	27	23	21	17	14	9	28	25	23	21	19	16	15	12	8
30	31	28	24	22	18	12	35	32	30	28	25	22	18	15	10	29	26	24	22	20	17	15	12	9
31	33	29	25	23	18	13	36	34	31	29	26	23	19	16	10	30	27	25	23	20	18	16	13	9



# Design of Spiral Reinforcement

- $A_{sp}$  = cross sectional area of spiral bar
- $D_{cc}$  = center to center diameter of spiral coil
- $A_{core}$  = area of column core to outside of spiral coils
- Pitch = vertical distance center to center of coils

$$\text{Pitch of spiral} \leq \frac{A_{sp} \pi D_{cc} f_y}{0.45 f'_c (A_g - A_{core})}$$

with the limit: 1"  $\leq$  clear distance between coils  $\leq$  3"

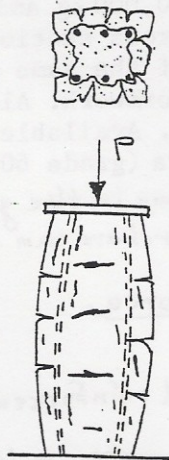

A

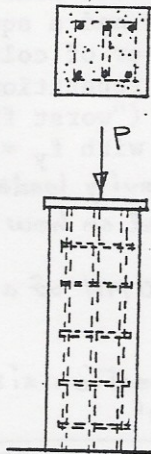

B

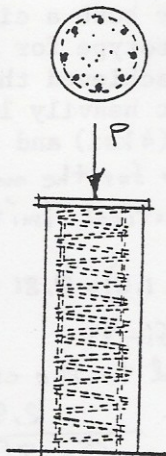

C

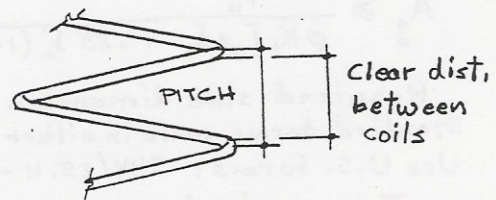
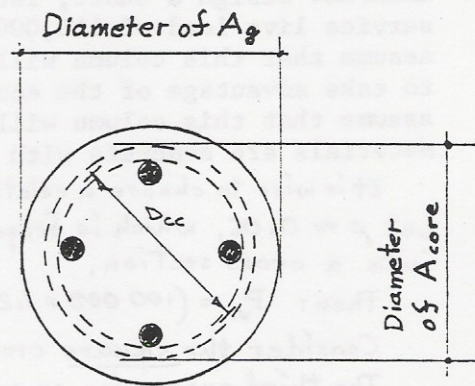

D