

Modulation and Multiplexing



Broadband Transmission

- A **carrier** is a high frequency signal that is modulated by audio, video, or data.
- A **radio-frequency (RF) wave** is an electromagnetic signal that is able to travel long distances through space.

Modulation and Multiplexing



Broadband Transmission

- A broadband transmission takes place when a carrier signal is modulated, amplified, and sent to the antenna for transmission.
- The two most common methods of modulation are:
 - ✦ Amplitude Modulation (AM)
 - ✦ Frequency Modulation (FM)
- Another method is called **phase modulation (PM)**, in which the phase angle of the sine wave is varied.

Modulation and Multiplexing

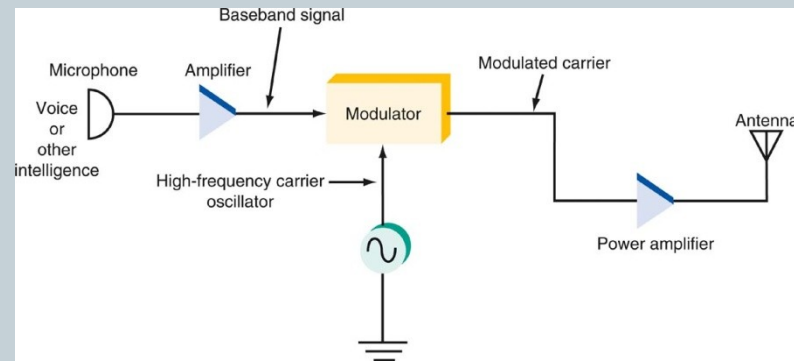

Figure 1: Modulation at the transmitter.

Modulation and Multiplexing

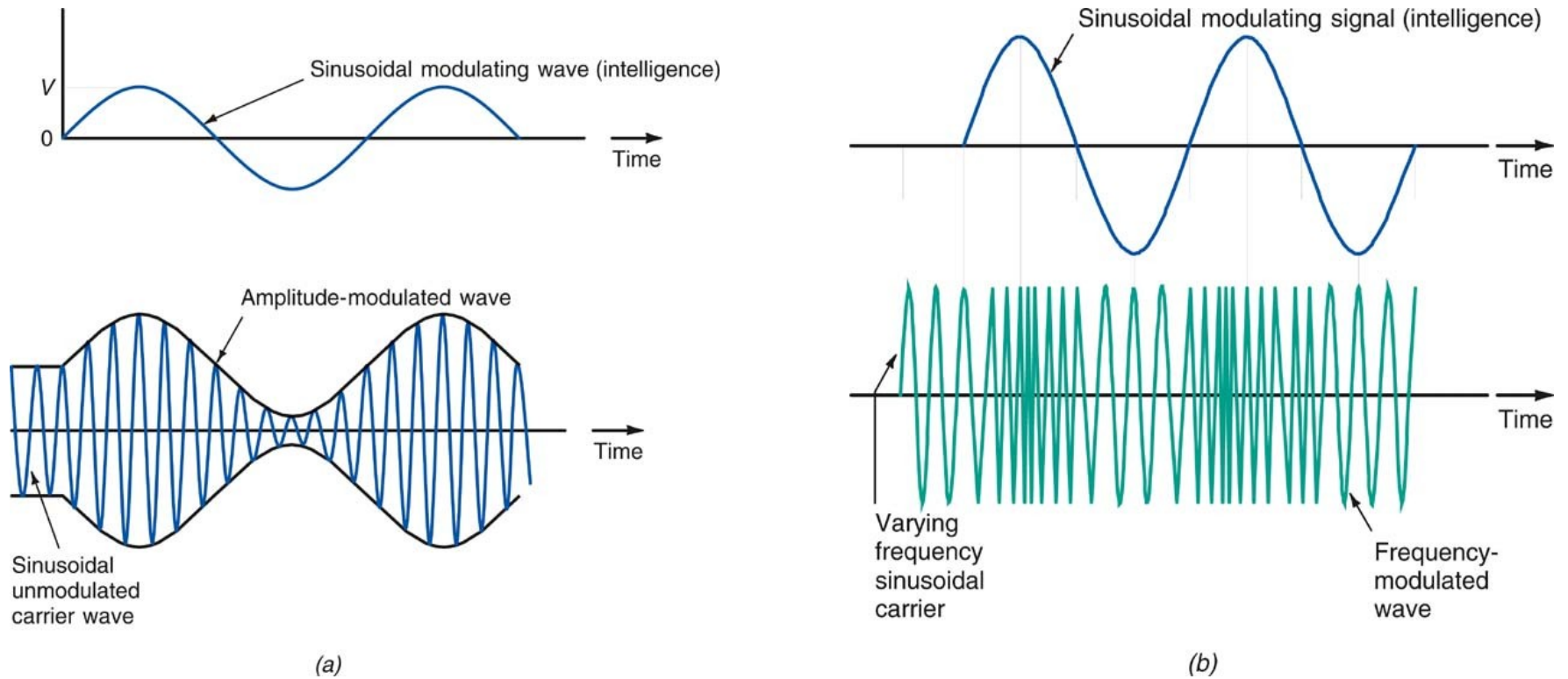

Figure 2: Types of modulation. (a) Amplitude modulation. (b) Frequency modulation.