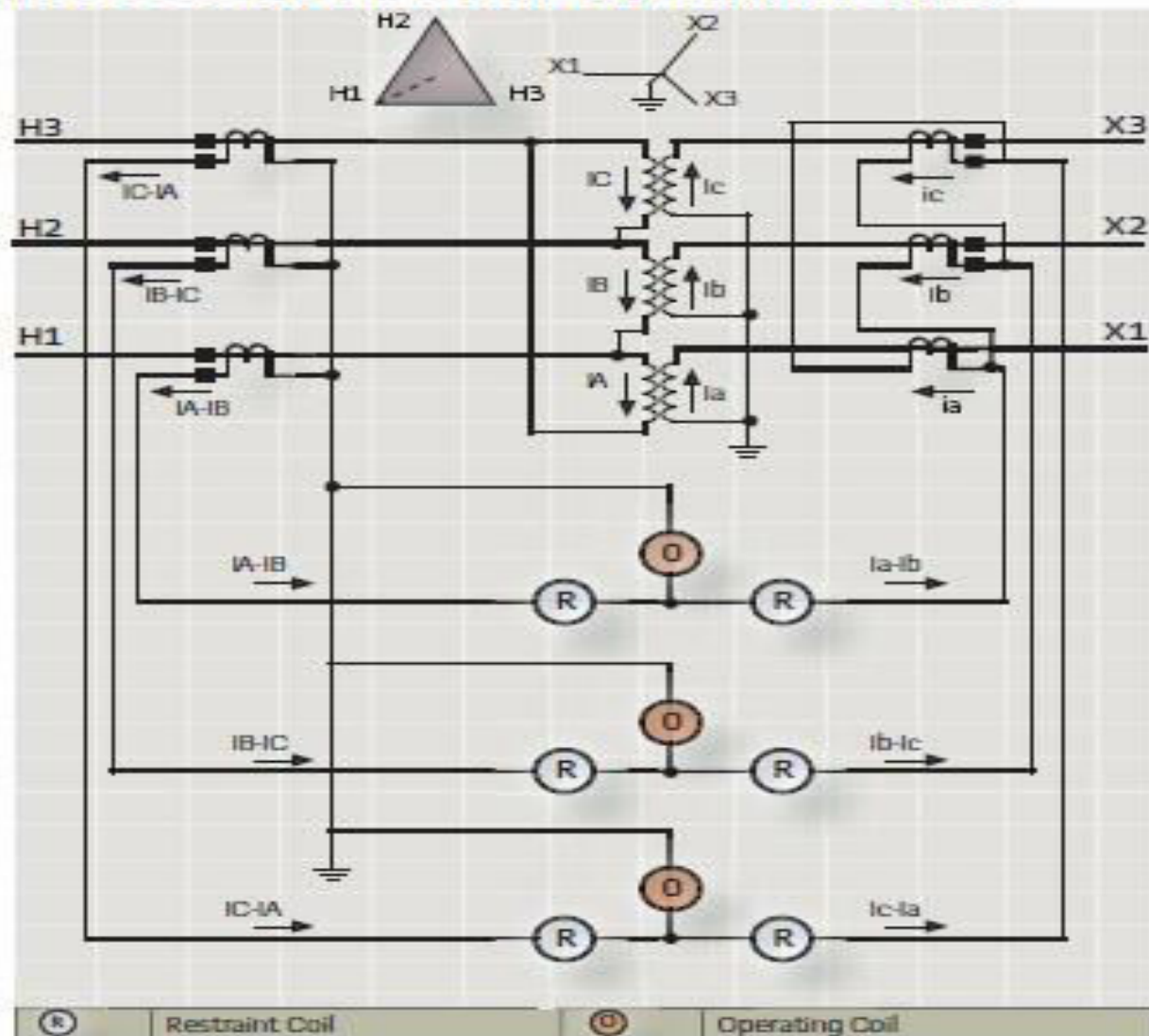

Fig. 8.3.2.2 11kV radial system; data for grading calculation

Location	Fault current		Max. section load A	CT ratio	Relay setting	
	A	A			%	Primary Amps
	Max.	Min.				
33kV bus						
11kV bus						
C.B. A	12 596	6 846	390	400/5	125	500
C.B. B	5 753	4 156	225	300/5	100	300
C.B. C	2 882	2 417	130	200/5	75	150
C.B. D	1 410	1 289	50	100/5	125	125
Medium voltage						
Bus F (1)	626	601	50			

2 Typical connections of CTs for differential protection of a Delta-Wye transformer



4 Operating characteristics of percentage differential relay



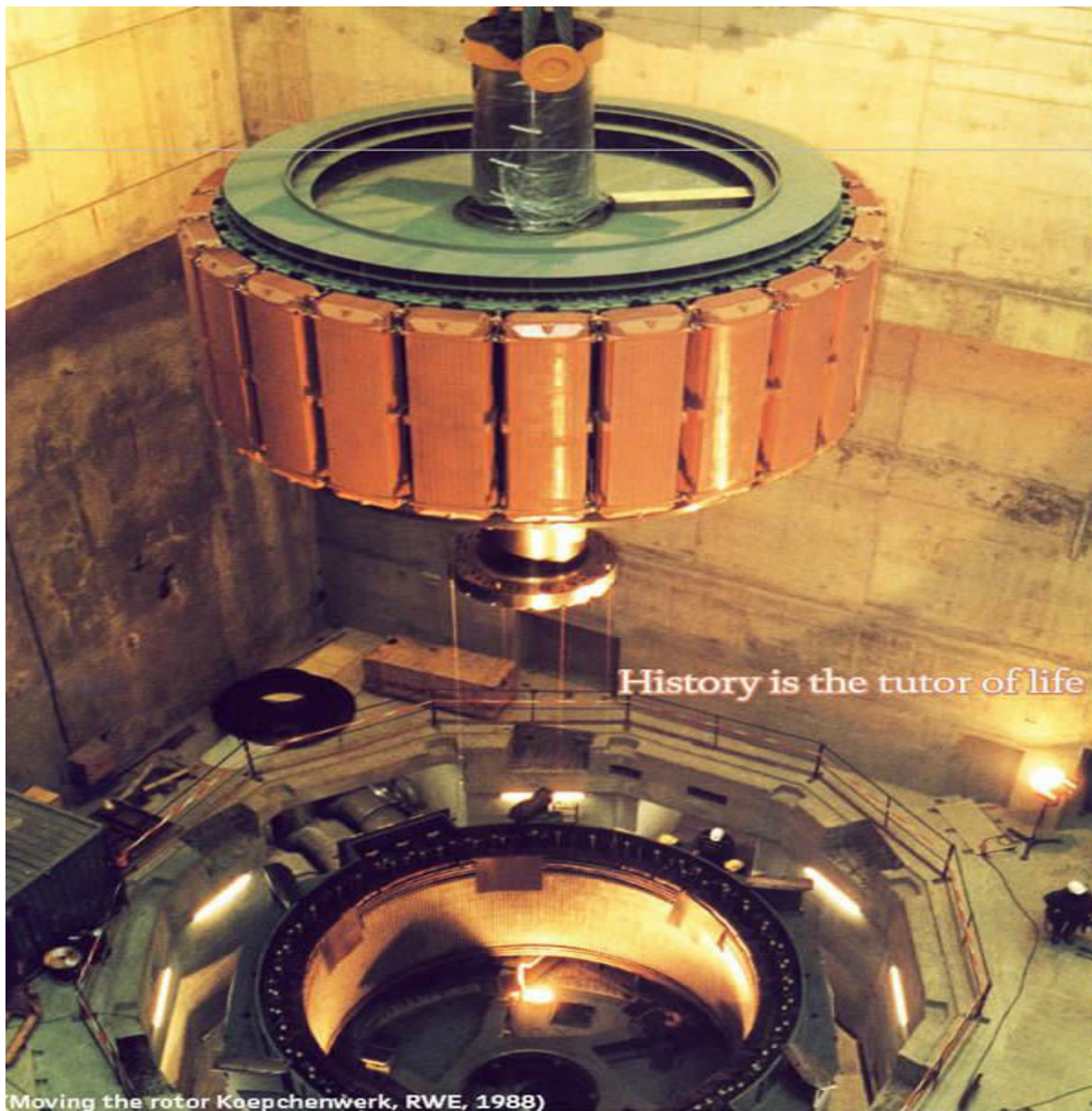

History is the tutor of life

(Moving the rotor Keopchenwerk, RWE, 1988)