Multiplexing techniques in tele-control

Multiplexing



Frequency Division Multiplexing

- FDM
- Useful bandwidth of medium exceeds required bandwidth of channel
- Each signal is modulated to a different carrier frequency
- Carrier frequencies separated so signals do not overlap (guard bands)
- e.g. broadcast radio
- Channel allocated even if no data

Frequency Division Multiplexing Diagram

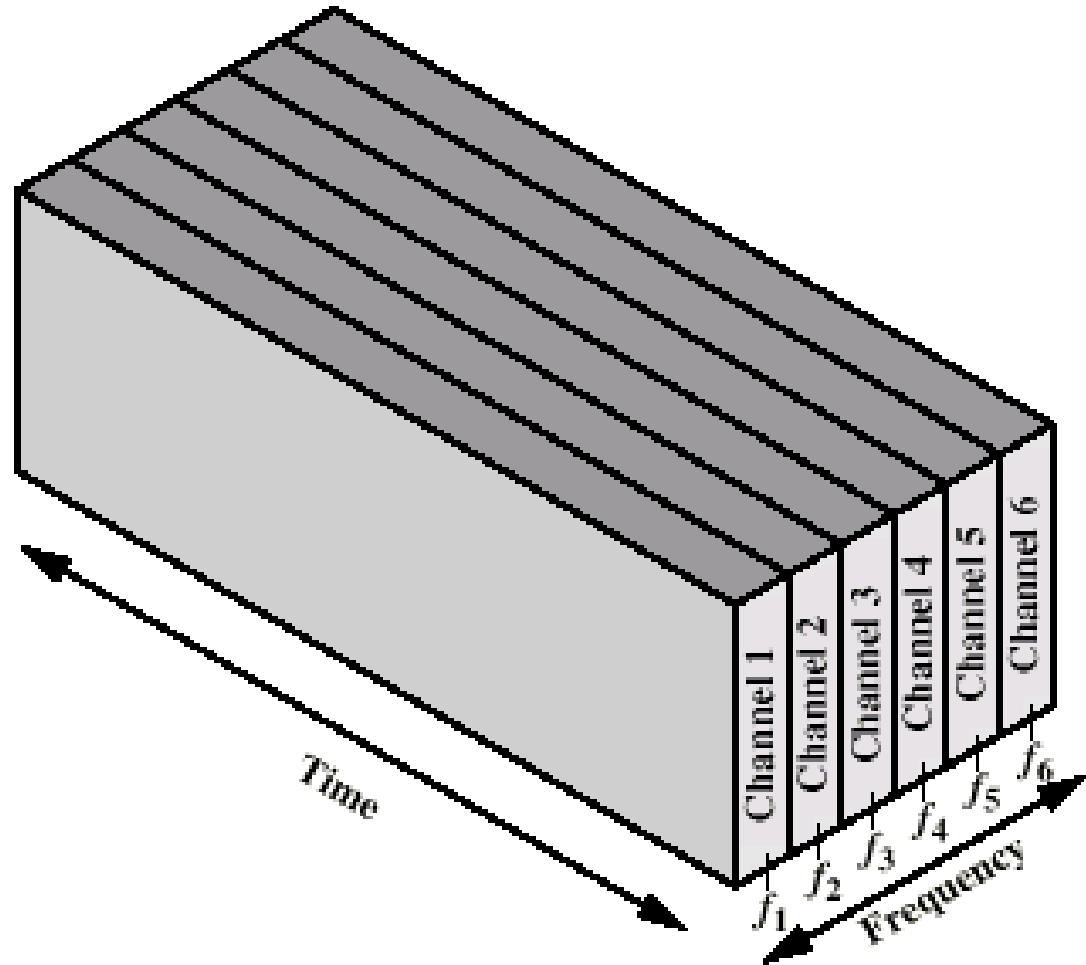

FDM System

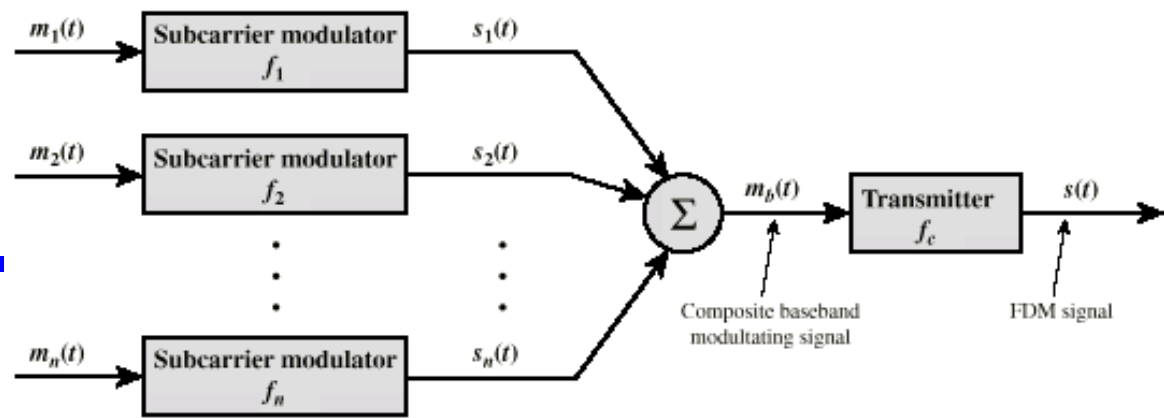

(a) Transmitter

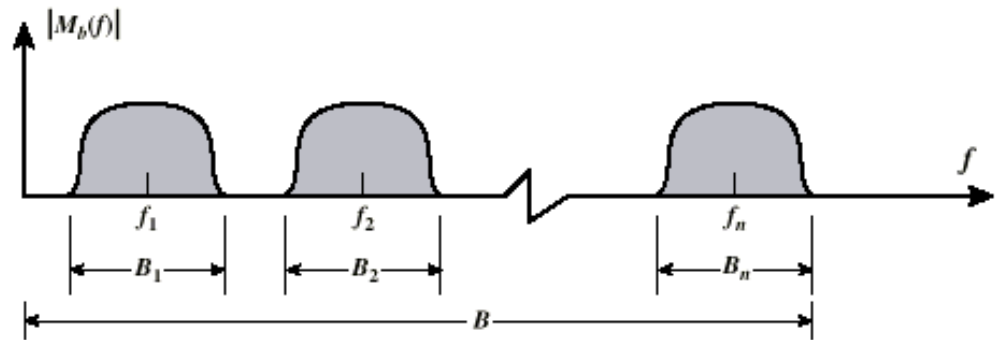

(b) Spectrum of composite baseband modulating signal

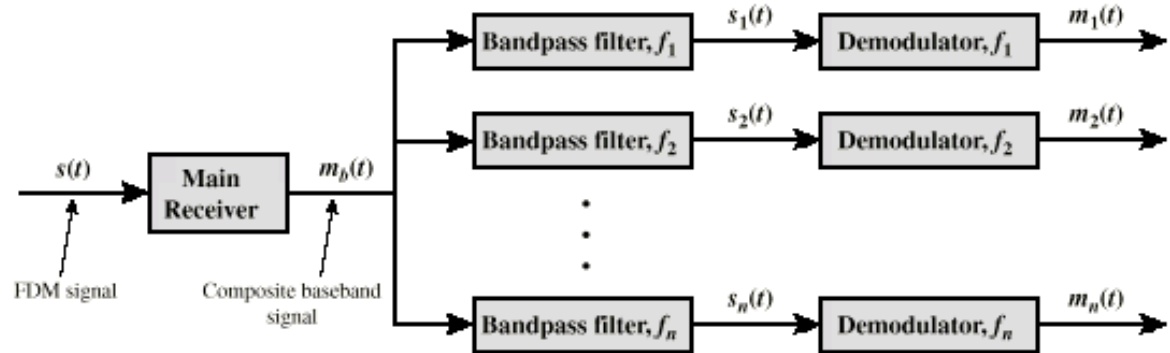

(c) Receiver

FDM of Three Voiceband Signals

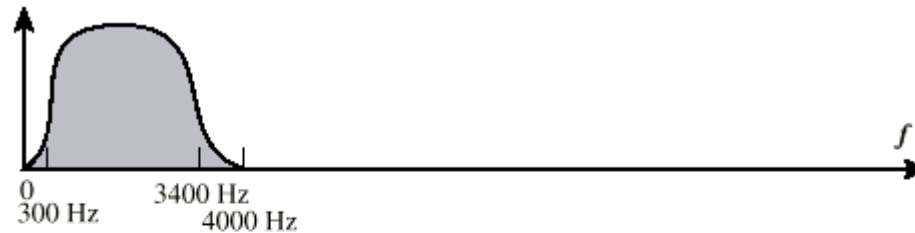

(a) Spectrum of $m_1(t)$, positive f

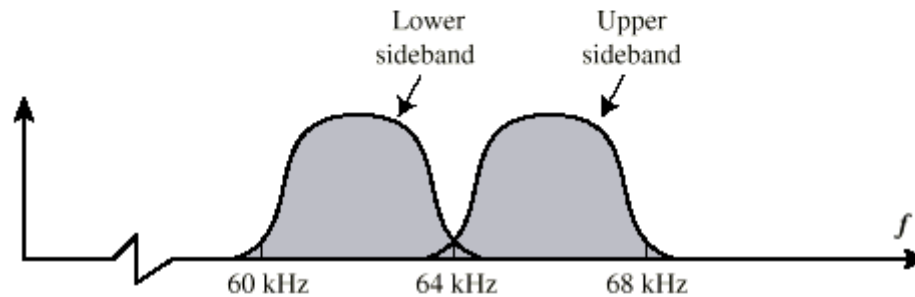

(b) Spectrum of $s_1(t)$ for $f_1 = 64$ kHz

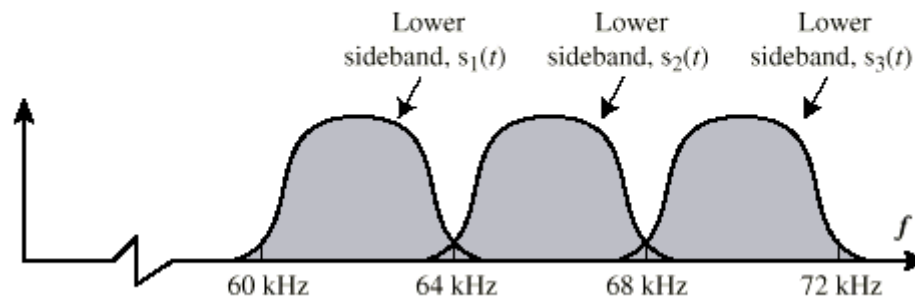

(c) Spectrum of composite signal using subcarriers at 64 kHz, 68 kHz, and 72 kHz

Analog Carrier Systems

- AT&T (USA)
- Hierarchy of FDM schemes
- Group
 - 12 voice channels (4kHz each) = 48kHz
 - Range 60kHz to 108kHz
- Supergroup
 - 60 channel
 - FDM of 5 group signals on carriers between 420kHz and 612 kHz
- Mastergroup
 - 10 supergroups

Wavelength Division Multiplexing

- Multiple beams of light at different frequency
- Carried by optical fiber
- A form of FDM
- Each color of light (wavelength) carries separate data channel
- 1997 Bell Labs
 - 100 beams
 - Each at 10 Gbps
 - Giving 1 terabit per second (Tbps)
- Commercial systems of 160 channels of 10 Gbps now available
- Lab systems (Alcatel) 256 channels at 39.8 Gbps each
 - 10.1 Tbps
 - Over 100km

WDM Operation

- Same general architecture as other FDM
- Number of sources generating laser beams at different frequencies
- Multiplexer consolidates sources for transmission over single fiber
- Optical amplifiers amplify all wavelengths
 - Typically tens of km apart
- Demux separates channels at the destination
- Mostly 1550nm wavelength range
- Was 200MHz per channel
- Now 50GHz

Dense Wavelength Division Multiplexing

- DWDM
- No official or standard definition
- Implies more channels more closely spaced than WDM
- 200GHz or less

Synchronous Time Division Multiplexing

- Data rate of medium exceeds data rate of digital signal to be transmitted
- Multiple digital signals interleaved in time
- May be at bit level or blocks
- Time slots preassigned to sources and fixed
- Time slots allocated even if no data
- Time slots do not have to be evenly distributed amongst sources

Time Division Multiplexing

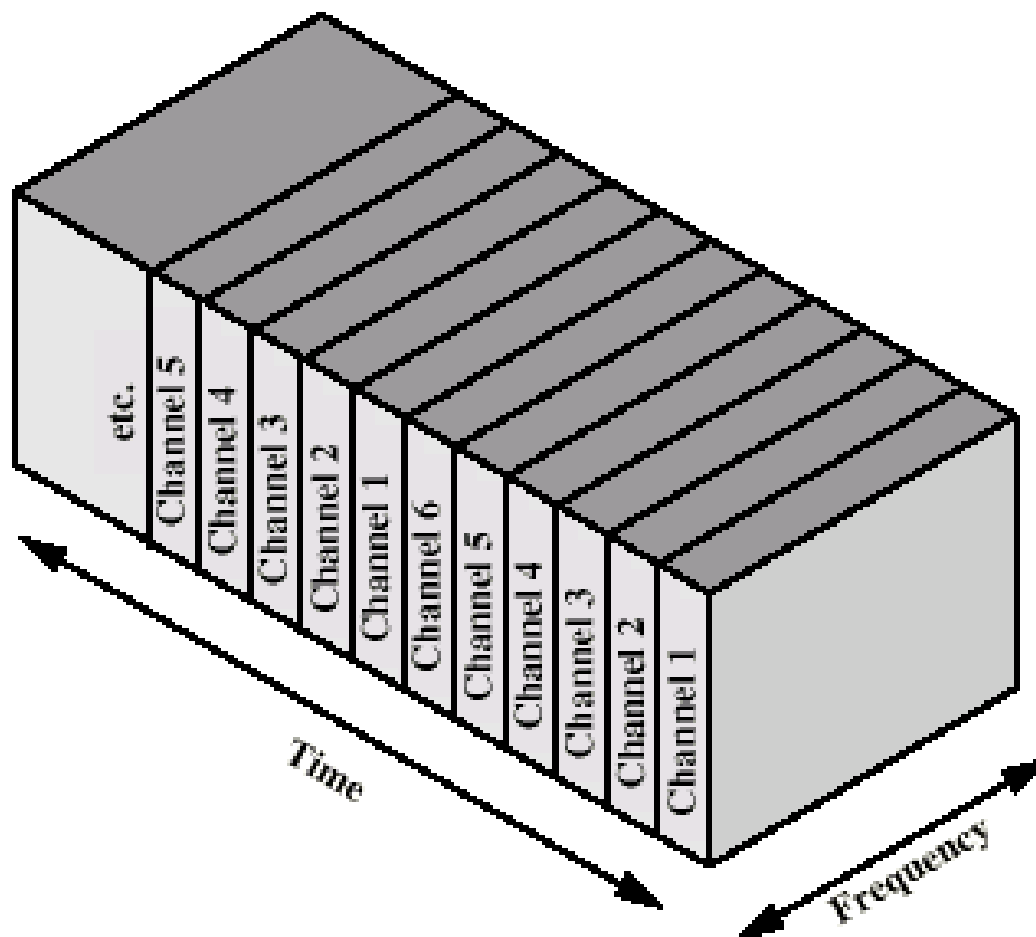

TDM System

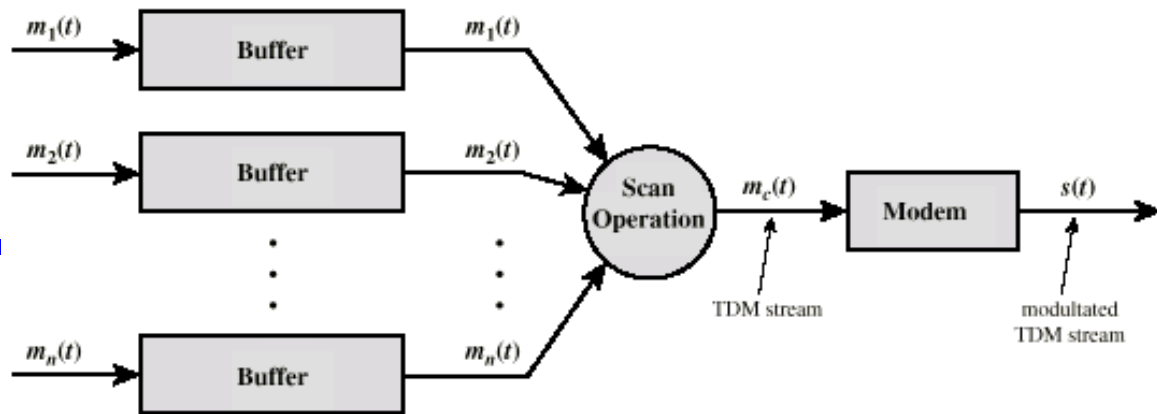

(a) Transmitter

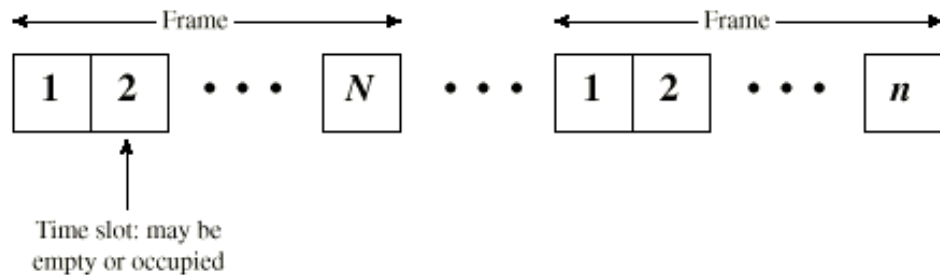

(b) TDM Frames

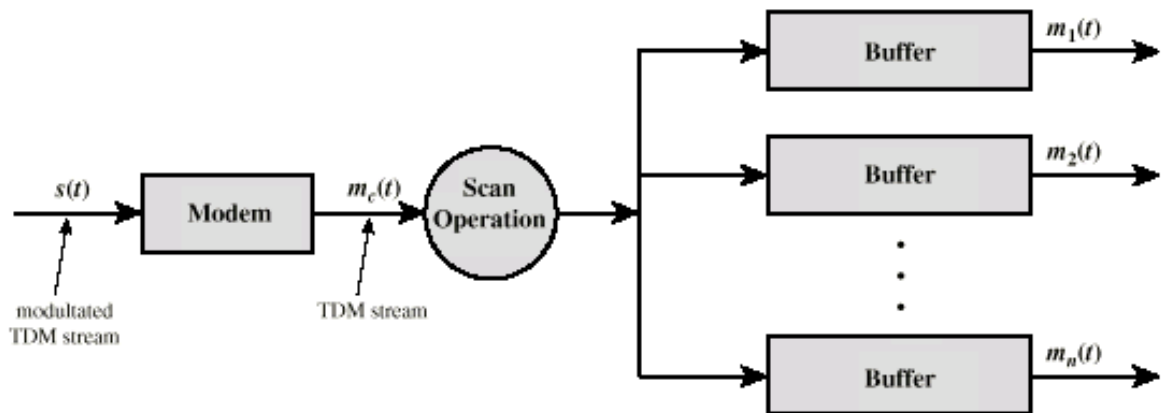

(c) Receiver

TDM Link Control

- No headers and trailers
- Data link control protocols not needed
- Flow control
 - Data rate of multiplexed line is fixed
 - If one channel receiver can not receive data, the others must carry on
 - The corresponding source must be quenched
 - This leaves empty slots
- Error control
 - Errors are detected and handled by individual channel systems

Data Link Control on TDM

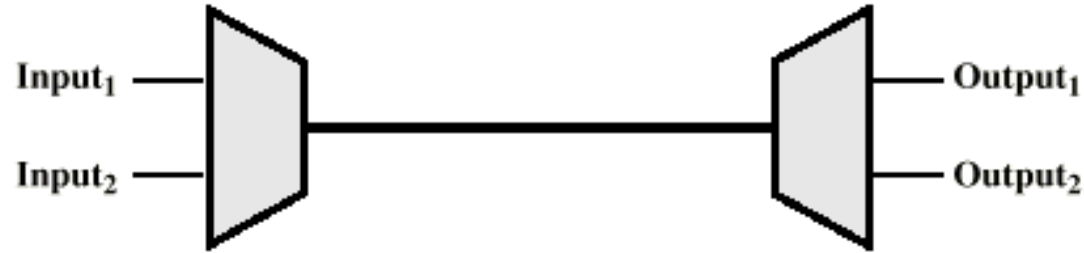

(a) Configuration

Input₁..... F₁ f₁ f₁ d₁ d₁ d₁ C₁ A₁ F₁ f₁ f₁ d₁ d₁ d₁ C₁ A₁ F₁
 Input₂... F₂ f₂ f₂ d₂ d₂ d₂ d₂ C₂ A₂ F₂ f₂ f₂ d₂ d₂ d₂ d₂ C₂ A₂ F₂

(b) Input data streams

... f₂ F₁ d₂ f₁ d₂ f₁ d₂ d₁ d₂ d₁ C₂ d₁ A₂ C₁ F₂ A₁ f₂ F₁ f₂ f₁ d₂ f₁ d₂ d₁ d₂ d₁ d₂ d₁ C₂ C₁ A₂ A₁ F₂ F₁

(c) Multiplexed data stream

Legend: F = flag field d = one octet of data field
 A = address field f = one octet of FCS field
 C = control field

Framing

- No flag or SYNC characters bracketing TDM frames
- Must provide synchronizing mechanism
- Added digit framing
 - One control bit added to each TDM frame
 - Looks like another channel - “control channel”
 - Identifiable bit pattern used on control channel
 - e.g. alternating 01010101...unlikely on a data channel
 - Can compare incoming bit patterns on each channel with sync pattern

Pulse Stuffing

- Problem - Synchronizing data sources
- Clocks in different sources drifting
- Data rates from different sources not related by simple rational number
- Solution - Pulse Stuffing
 - Outgoing data rate (excluding framing bits) higher than sum of incoming rates
 - Stuff extra dummy bits or pulses into each incoming signal until it matches local clock
 - Stuffed pulses inserted at fixed locations in frame and removed at demultiplexer

TDM of Analog and Digital Sources

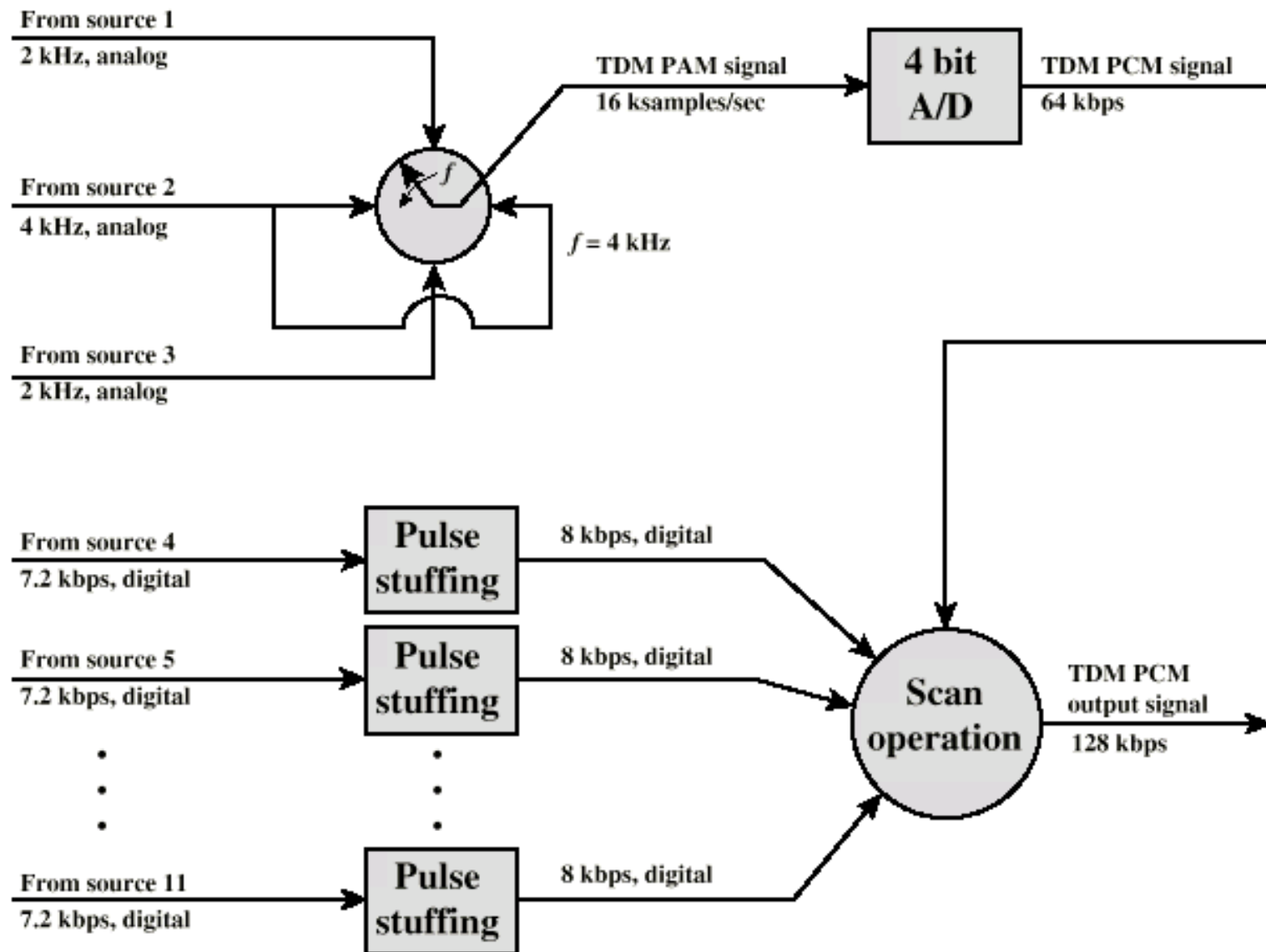

Digital Carrier Systems

- Hierarchy of TDM
- USA/Canada/Japan use one system
- ITU-T use a similar (but different) system
- US system based on DS-1 format
- Multiplexes 24 channels
- Each frame has 8 bits per channel plus one framing bit
- 193 bits per frame

Digital Carrier Systems (2)

- For voice each channel contains one word of digitized data (PCM, 8000 samples per sec)
 - Data rate $8000 \times 193 = 1.544 \text{ Mbps}$
 - Five out of six frames have 8 bit PCM samples
 - Sixth frame is 7 bit PCM word plus signaling bit
 - Signaling bits form stream for each channel containing control and routing info
- Same format for digital data
 - 23 channels of data
 - 7 bits per frame plus indicator bit for data or systems control
 - 24th channel is sync