

Unit 1

Lecture 7

8085 MPU

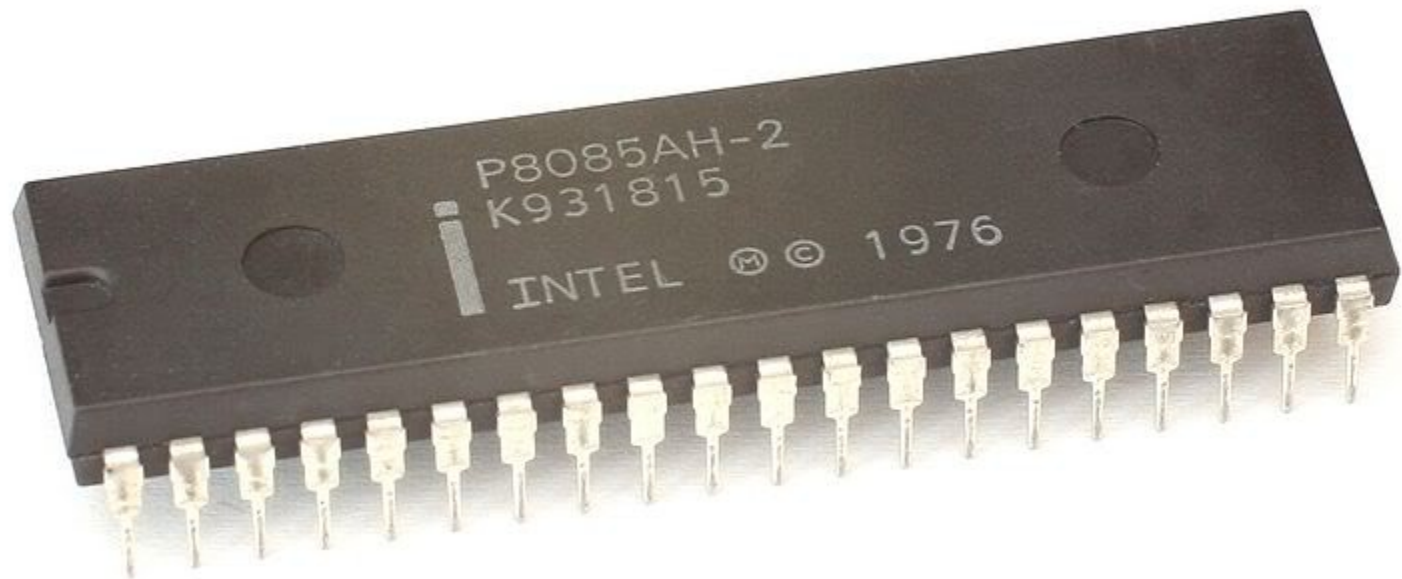

Intel 8085 Pin Configuration

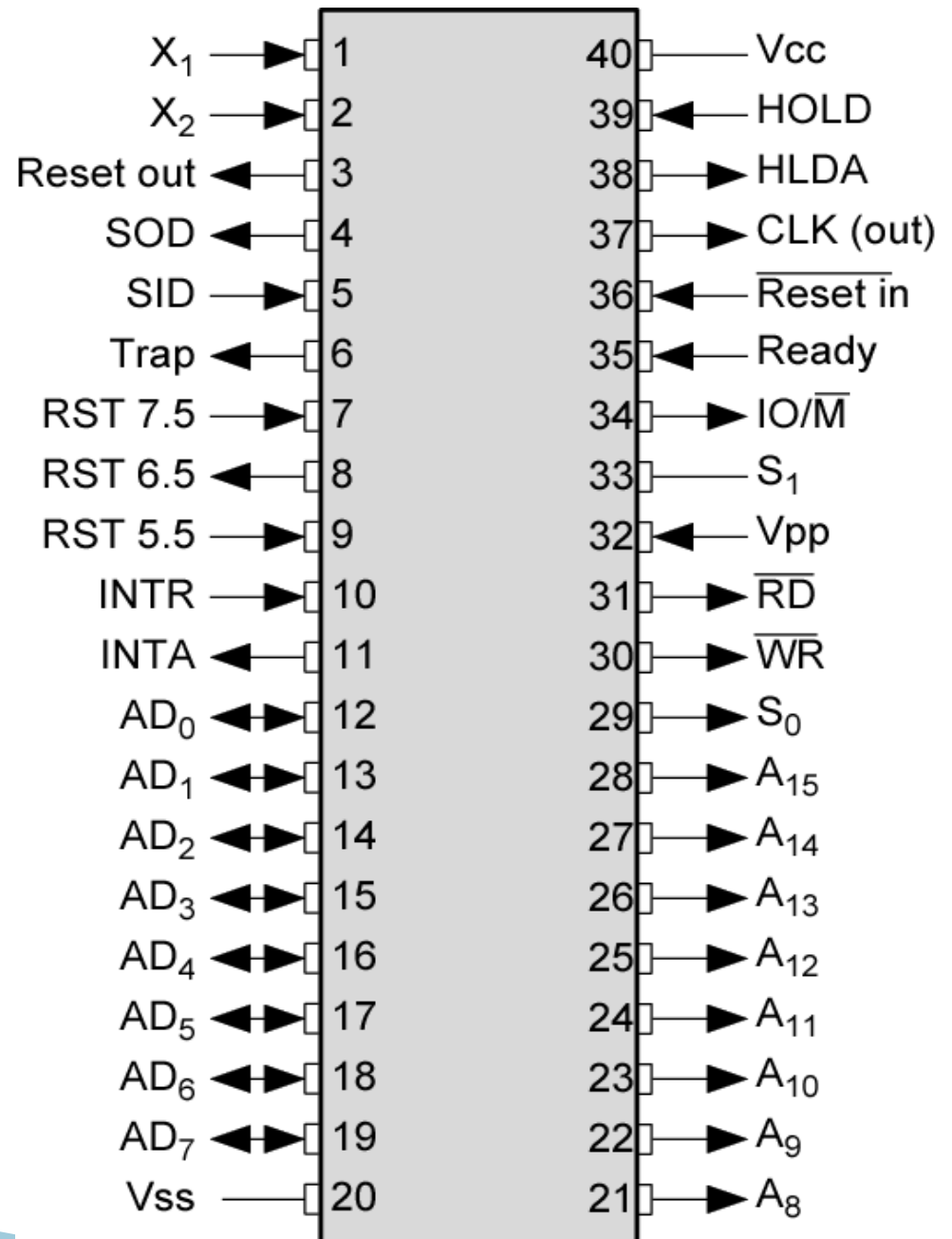

Signals and I/O Pins

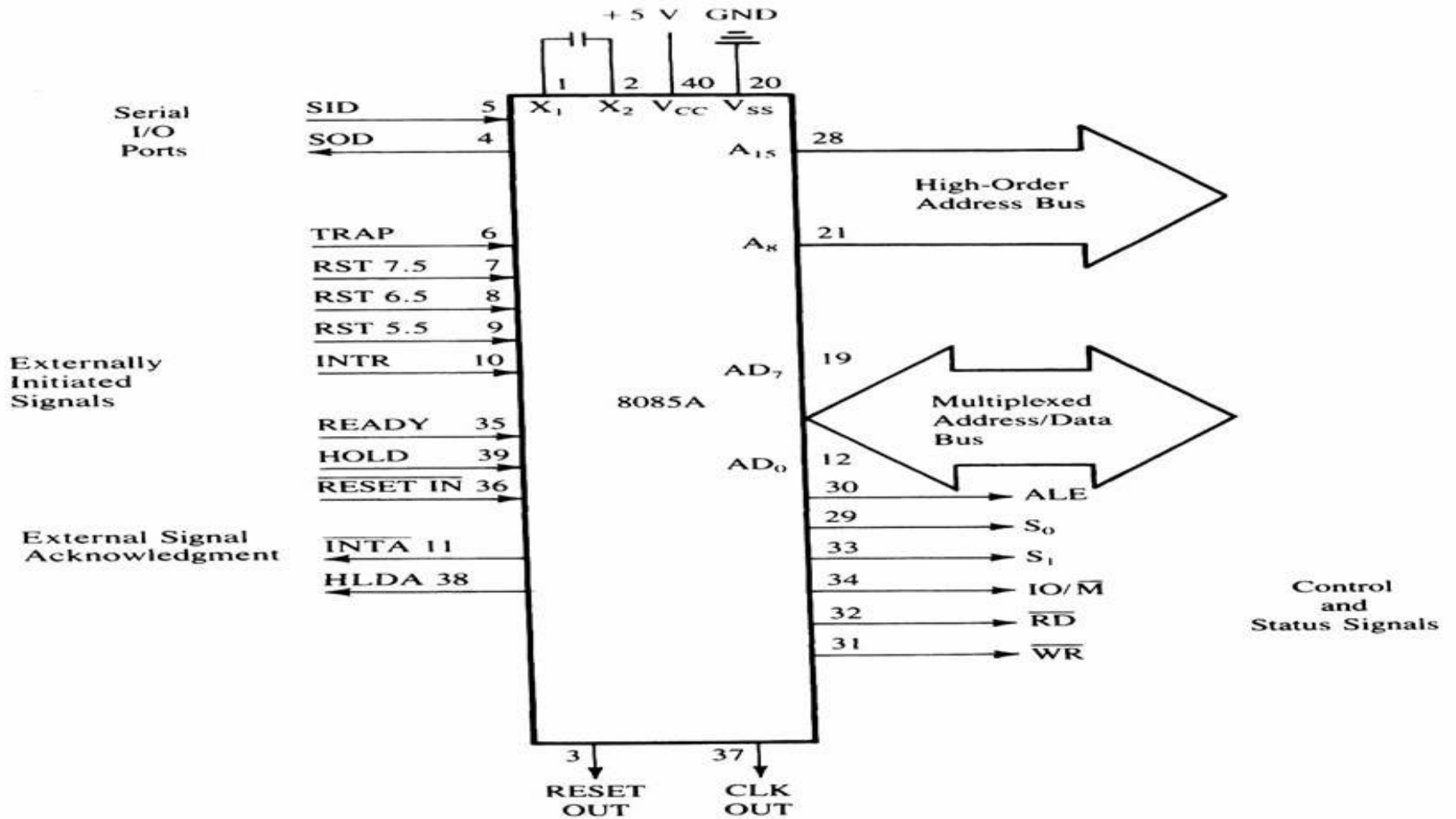

Intel 8085 CPU Block Diagram

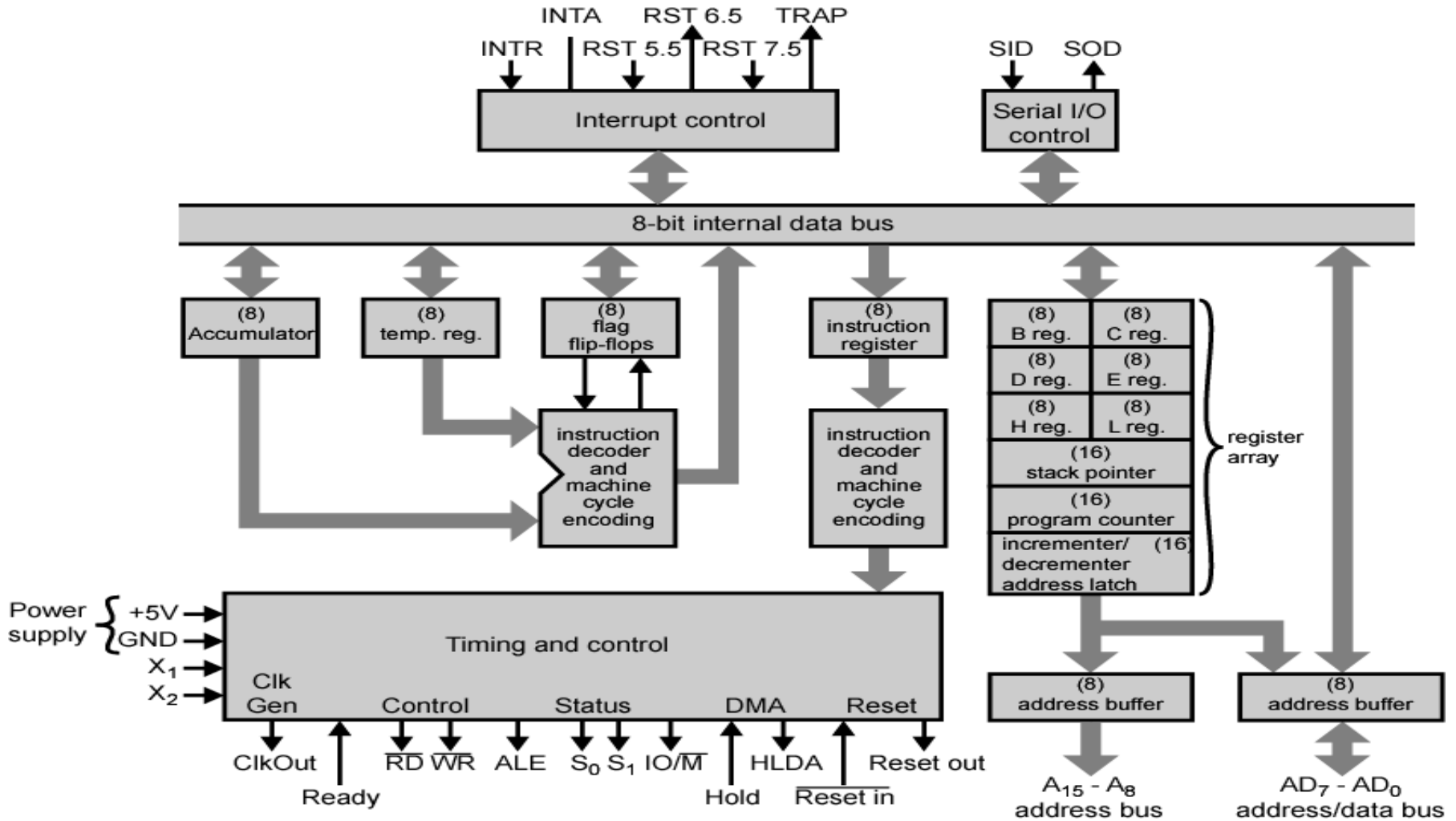

The 8085 and Its Buses

- The 8085 is an 8-bit general purpose microprocessor that can address 64K Byte of memory.
- It has 40 pins and uses +5V for power. It can run at a maximum frequency of 3 MHz.
 - The pins on the chip can be grouped into 6 groups:
 - Address Bus.
 - Data Bus.
 - Control and Status Signals.
 - Power supply and frequency.
 - Externally Initiated Signals.
 - Serial I/O ports.

The Address and Data Bus Systems

- The address bus has 8 signal lines A8 – A15 which are unidirectional.
- The other 8 address bits are multiplexed (time shared) with the 8 data bits.
 - So, the bits AD0 – AD7 are bi-directional and serve as A0 – A7 and D0 – D7 at the same time.
 - During the execution of the instruction, these lines carry the address bits during the early part, then during the late parts of the execution, they carry the 8 data bits.
 - In order to separate the address from the data, we can use a latch to save the value before the function of the bits changes.

The Control and Status Signals

- There are 4 main control and status signals. These are:
 - ALE: Address Latch Enable. This signal is a pulse that become 1 when the AD0 – AD7 lines have an address on them. It becomes 0 after that. This signal can be used to enable a latch to save the address bits from the AD lines.
 - RD: Read. Active low.
 - WR: Write. Active low.
 - IO/M: This signal specifies whether the operation is a memory operation (IO/M=0) or an I/O operation (IO/M=1).
 - S1 and S0 : Status signals to specify the kind of operation being performed. Usually not used in small systems.

The Flags register

- There is also a flag register whose bits are affected by the arithmetic & logic operations.

- **S-sign flag**

The sign flag is set if bit D7 of the accumulator is set

after an arithmetic or logic operation.

- **Z-zero flag**

Set if the result of the ALU operation is 0. Otherwise

is reset. This flag is affected by operations on the accumulator as well as other registers. (DCR B).

The Flags register

AC–Auxiliary Carry

This flag is set when a carry is generated from bit D3 and passed to D4 . This flag is used only internally for BCD operations.

P–Parity flag

After an ALU operation, if the result has an even # of 1s, the p–flag is set. Otherwise it is cleared. So, the flag can be used to indicate even parity.

CY–carry flag

This flag is set when a carry is generated from bit D7 after an unsigned operation.

OV–Overflow flag

This flag is set when an overflow occurs after a signed operation.

More on the 8085 machine cycles

- ▶ The 8085 executes several types of instructions with each requiring a different number of operations of different types. However, the operations can be grouped into a small set.
- ▶ The three main types are:
 - Memory Read and Write.
 - I/O Read and Write.
 - Request Acknowledge.
- ▶ These can be further divided into various smaller operations (machine cycles).

Opcode Fetch Machine Cycle

- The first step of executing any instruction is the Opcode fetch cycle.
 - In this cycle, the microprocessor brings in the instruction's Opcode from memory.
 - To differentiate this machine cycle from the very similar "memory read" cycle, the control & status signals are set as follows:
 - $IO/M=0$, s_0 and s_1 are both 1.
 - This machine cycle has four T-states.
 - The 8085 uses the first 3 T-states to fetch the opcode.
 - T4 is used to decode and execute it.
 - It is also possible for an instruction to have 6 T-states in an opcode fetch machine cycle.

Memory Read Machine Cycle

- ▶ The memory read machine cycle is exactly the same as the opcode fetch except:
 - It only has 3 T-states
 - The s0 signal is set to 0 instead.

The Memory Read Machine Cycle

- To understand the memory read machine cycle, let's study the execution of the following instruction:

- MVI A, 32

- In memory, this instruction looks like:

- The first byte 3EH represents the opcode for loading a byte into the accumulator (MVI A), the second byte is the data to be loaded.

- The 8085 needs to read these two bytes from memory before it can execute the instruction. Therefore, it will need at least two machine cycles.

- The first machine cycle is the opcode fetch discussed earlier.
 - The second machine cycle is the Memory Read Cycle.

2000H	3E
2001H	32

Example of an 8085 based computer

- ❖ System includes interfacing devices such as buffers, decoders, and latches.
- ❖ 8085 MPU module includes devices such as 8085 microprocessor, an octal latch, and logic gates.
- ❖ Three machine cycles:
 - ❖ Opcode fetch
 - ❖ Memory read machine cycle
 - ❖ Memory write cycle
- ❖ Microprocessor external communication can be divided into three categories:
 - ❖ Memory read and write
 - ❖ I/O read and write
 - ❖ Request acknowledge