

Unit 1

Lecture 8

Memory interfacing

- ▶ There needs to be a lot of interaction between the microprocessor and the memory for the exchange of information during program execution.
 - Memory has its requirements on control signals and their timing.
 - The microprocessor has its requirements as well.
 - ▶ The interfacing operation is simply the matching of these requirements.
- 

Memory structure & its requirements

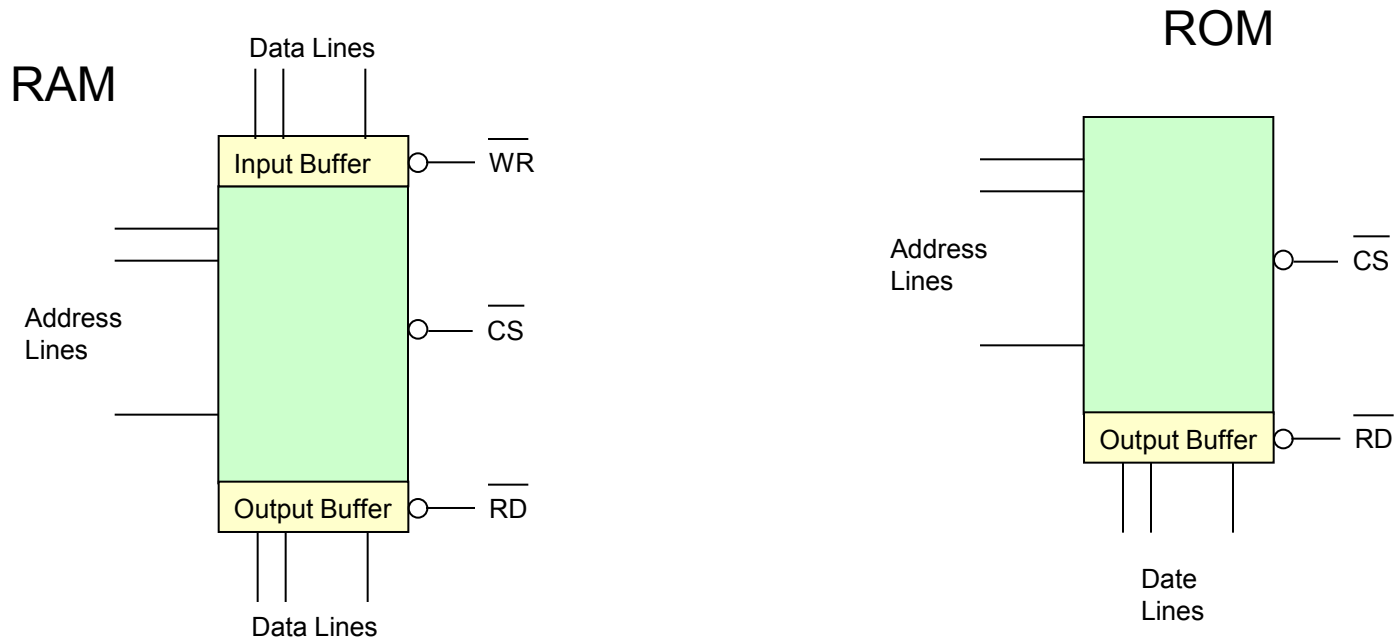

- ▶ The way of interfacing the above two chips to the microprocessor is the same.
 - However, the ROM does not have a \overline{WR} signal.

Interfacing Memory

- Accessing memory can be summarized into the following three steps:
 - Select the chip.
 - Identify the memory register.
 - Enable the appropriate buffer.
- Translating this to microprocessor domain:
 - The microprocessor places a 16-bit address on the address bus.
 - Part of the address bus will select the chip and the other part will go through the address decoder to select the register.
 - The signals IO/M and RD combined indicate that a memory read operation is in progress. The MEMR signal can be used to enable the RD line on the memory chip.

Control and Status Signals

TABLE 4.1

8085 Machine Cycle Status and Control Signals

Machine Cycle	Status			Control Signals
	$\overline{\text{IO/M}}$	S_1	S_0	
Opcode Fetch	0	1	1	$\overline{\text{RD}} = 0$
Memory Read	0	1	0	$\overline{\text{RD}} = 0$
Memory Write	0	0	1	$\overline{\text{WR}} = 0$
I/O Read	1	1	0	$\overline{\text{RD}} = 0$
I/O Write	1	0	1	$\overline{\text{WR}} = 0$
Interrupt Acknowledge	1	1	1	$\overline{\text{INTA}} = 0$
Halt	Z	0	0	} $\overline{\text{RD}}, \overline{\text{WR}} = \text{Z}$ and $\overline{\text{INTA}} = 1$
Hold	Z	X	X	
Reset	Z	X	X	

NOTE: Z = Tri-state (high impedance)

X = Unspecified

Direct Memory Access (DMA)

- ▶ DMA is an IO technique where external IO device requests the use of the MPU buses.
- ▶ Allows external IO devices to gain high speed access to the memory.
 - Example of IO devices that use DMA: disk memory system.
- ▶ HOLD and HLDA are used for DMA.
- ▶ If HOLD=1, 8085 will place its address, data and control pins at their high-impedance.
- ▶ A DMA acknowledgement is signaled by HLDA=1.

MPU Communication and Bus Timing

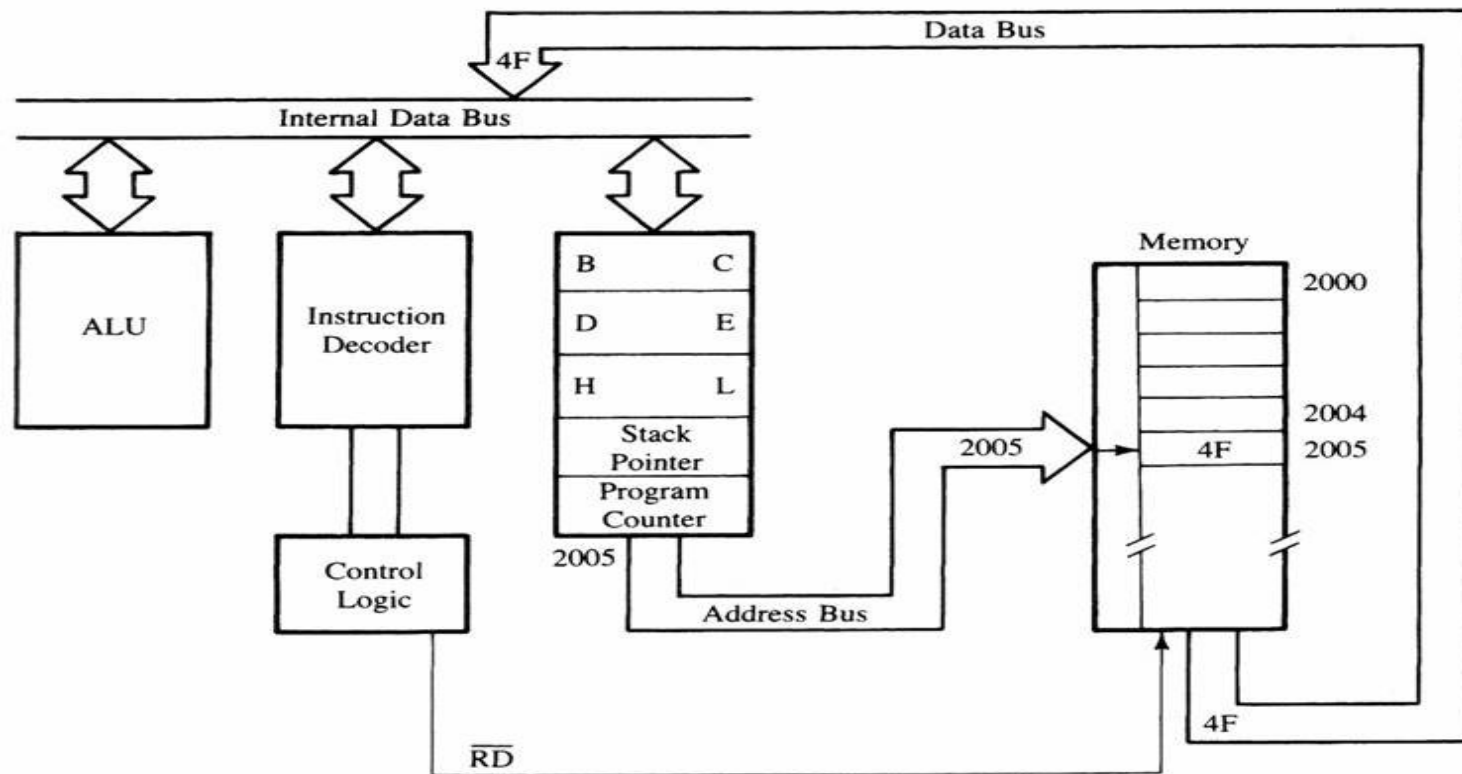

Moving data form memory to MPU using instruction **MOV C, A** (code machine 4FH = 0100 1111)

MPU Communication and Bus Timing

- The Fetch Execute Sequence :
 1. The μ p placed a 16 bit memory address from PC (program counter) to address bus.
 - Figure 4: at T1
 - The high order address, 20H, is placed at A15 - A8.
 - the low order address, 05H, is placed at AD7 - AD0 and ALE is active high.
 - Synchronously the IO/M is in active low condition to show it is a memory operation.
 2. At T2 the active low control signal, RD, is activated so as to activate read operation; it is to indicate that the MPU is in fetch mode operation.

MPU Communication and Bus Timing

3. T3: The active low RD signal enabled the byte instruction, 4FH, to be placed on AD7 – AD0 and transferred to the MPU. While RD high, the data bus will be in high impedance mode.
4. T4: The machine code, 4FH, will then be decoded in instruction decoder. The content of accumulator (A) will then copied into C register at time state, T4.

MPU Communication and Bus Timing

