

Single phase transformer tap changer

Regulating the voltage of a transformer is a requirement that often arises in a power application or power system. In an application it may be needed

1. To supply a desired voltage to the load.
2. To counter the voltage drops due to loads.
3. To counter the input supply voltage changes on load.

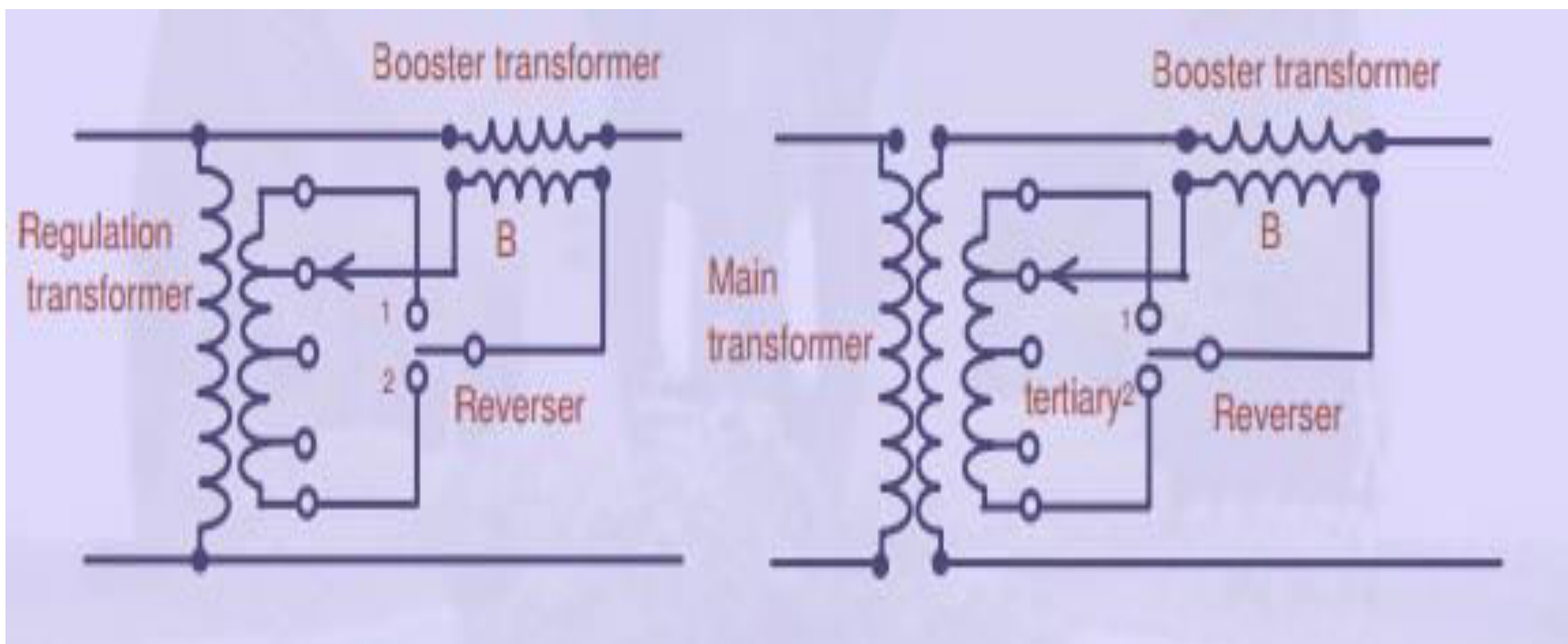

Figure : Tap changing and Buck Boost arrangement

The voltage control is performed by changing the turns ratio. This is done by provision of taps in the winding. The volts per turn available in large transformers is quite high and hence a change of even one turn on the LV side represents a large percentage change in the voltage. Also the LV currents are normally too large to take out the tapping from the windings. LV winding being the inner winding in a core type transformer adds to the

difficulty of taking out of the taps. Hence irrespective of the end use for which tapping is put to, taps are provided on the HV winding. Provision of taps to control voltage is called tap changing. In the case of power systems, voltage levels are some times changed by injecting a suitable voltage in series with the line. This may be called buck-boost arrangement. In addition to the magnitude, phase of the injected voltage may be varied in power systems.

Tap changing can be effected when a) the transformers is on no- load and b) the load is still remains connected to the transformer. These are called off load tap changing and on load tap changing. The Off load tap changing relatively costs less. The tap positions are changed when the transformer is taken out of the circuit and reconnected.