

Three-phase half-wave Cycloconverters

3 Φ to single phase conversion can be achieved using either of the dual converter circuit topologies shown below:

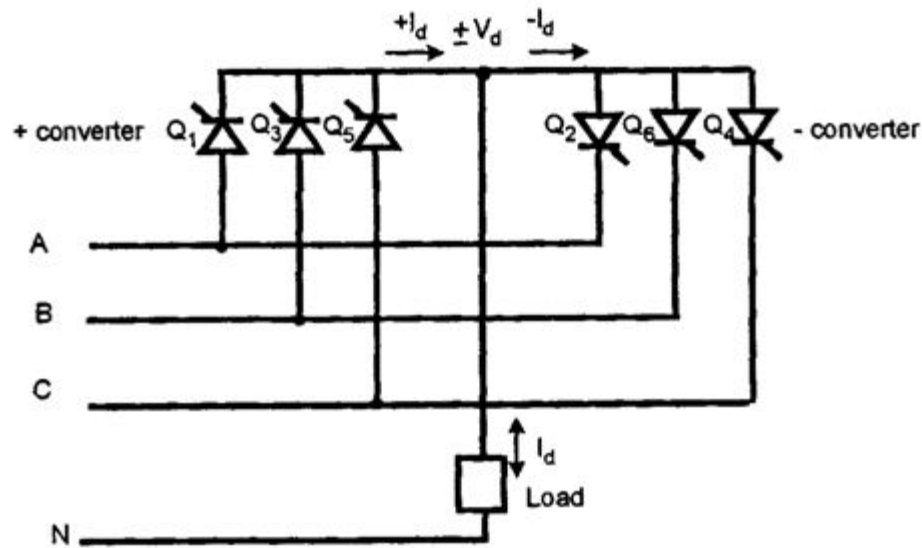

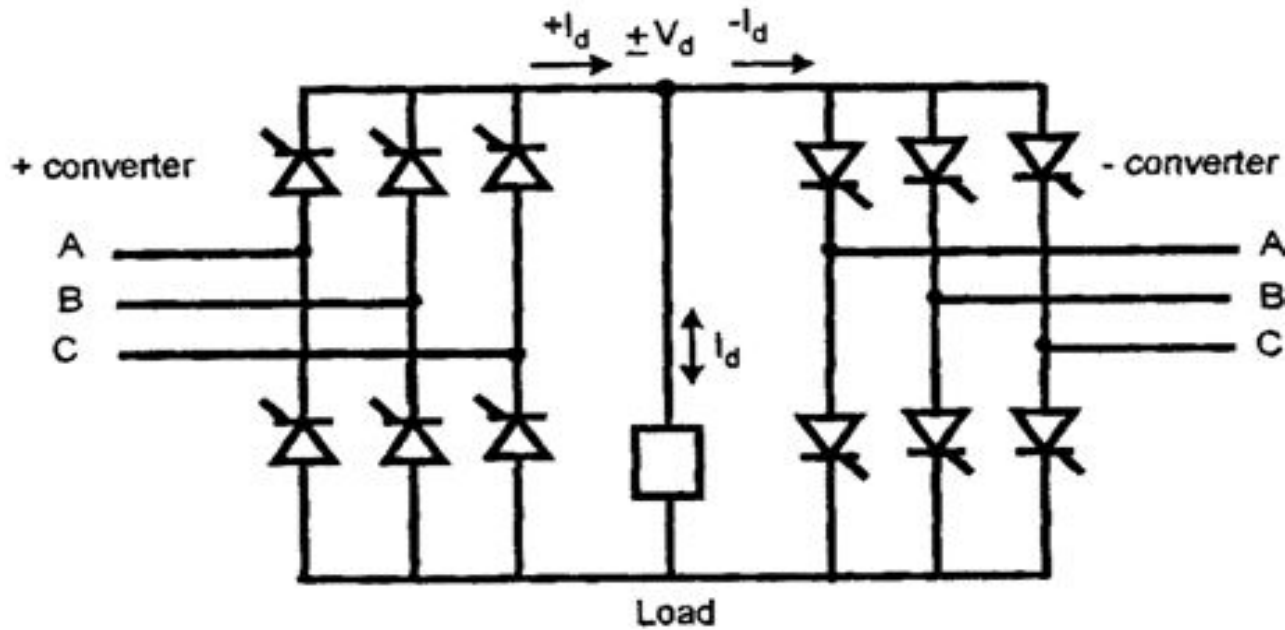

A Thevenin equivalent circuit for the dual converter is shown next slide:

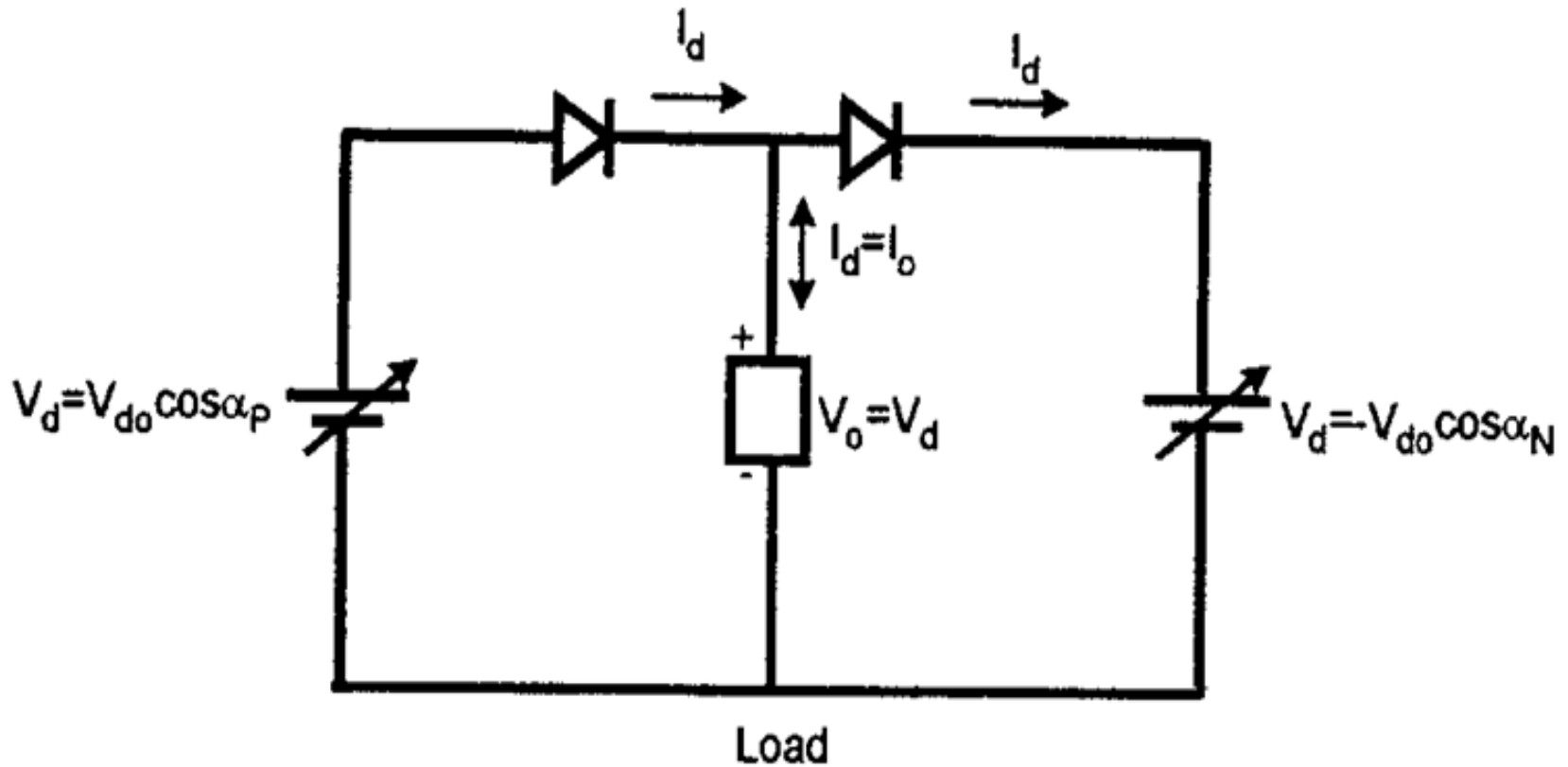

The input and output voltages are adjusted to be equal and the load current can flow in either direction. Thus,

$$V_0 = V_d = V_{d0} \cos \alpha_p = -V_{d0} \cos \alpha_n$$

where V_{d0} is the dc output voltage of each converter at zero firing angle and α_p and α_n are the input and output firing angles. For a 3Φ half-wave converter $V_{d0} = 0.675V_L$ and $V_{d0} = 1.35V_L$ for the bridge converter (V_L is the rms line voltage).

Voltage-tracking between the input and output voltages is achieved by setting the sum of the firing angles to π . Positive or negative voltage polarity can be achieved as shown below:

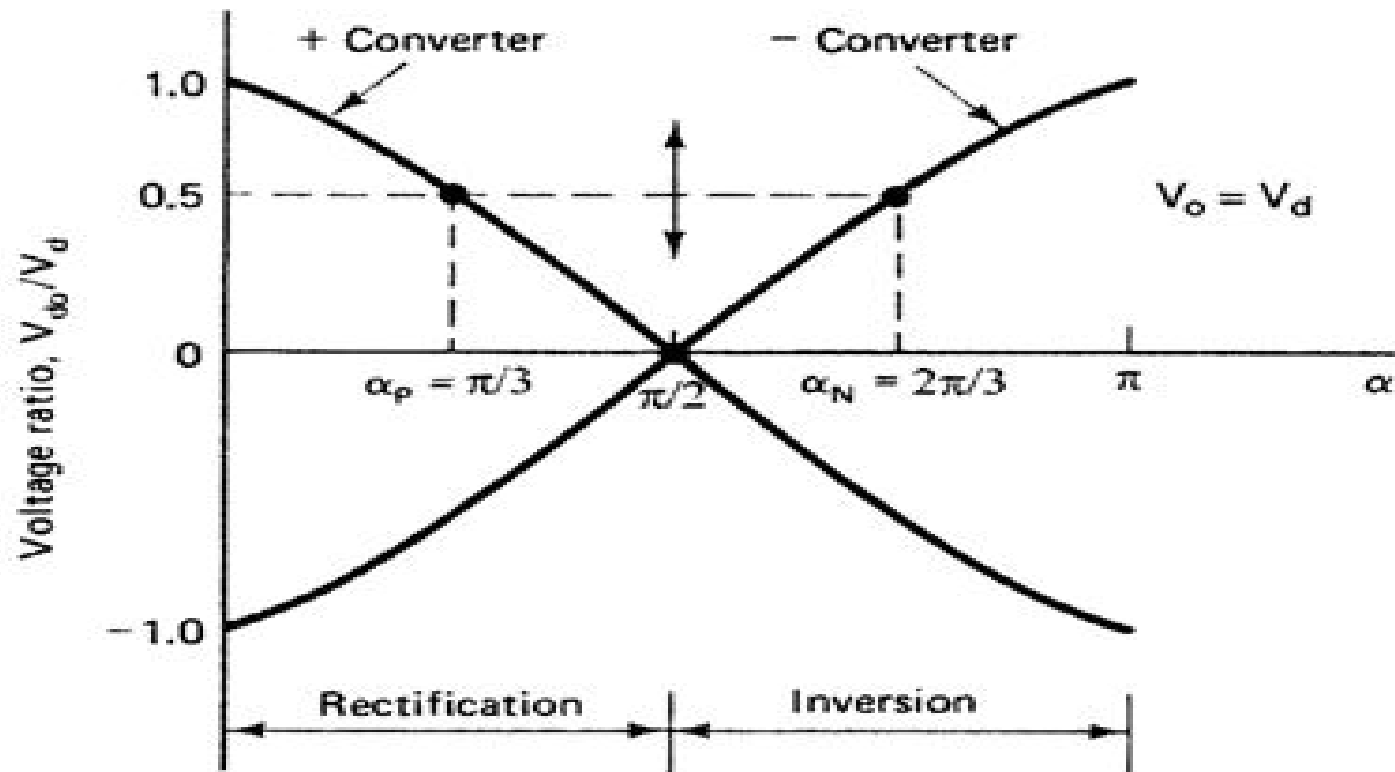

A 3Φ to 3Φ cycloconverter can be implemented using 18 thyristors as shown in next slide:

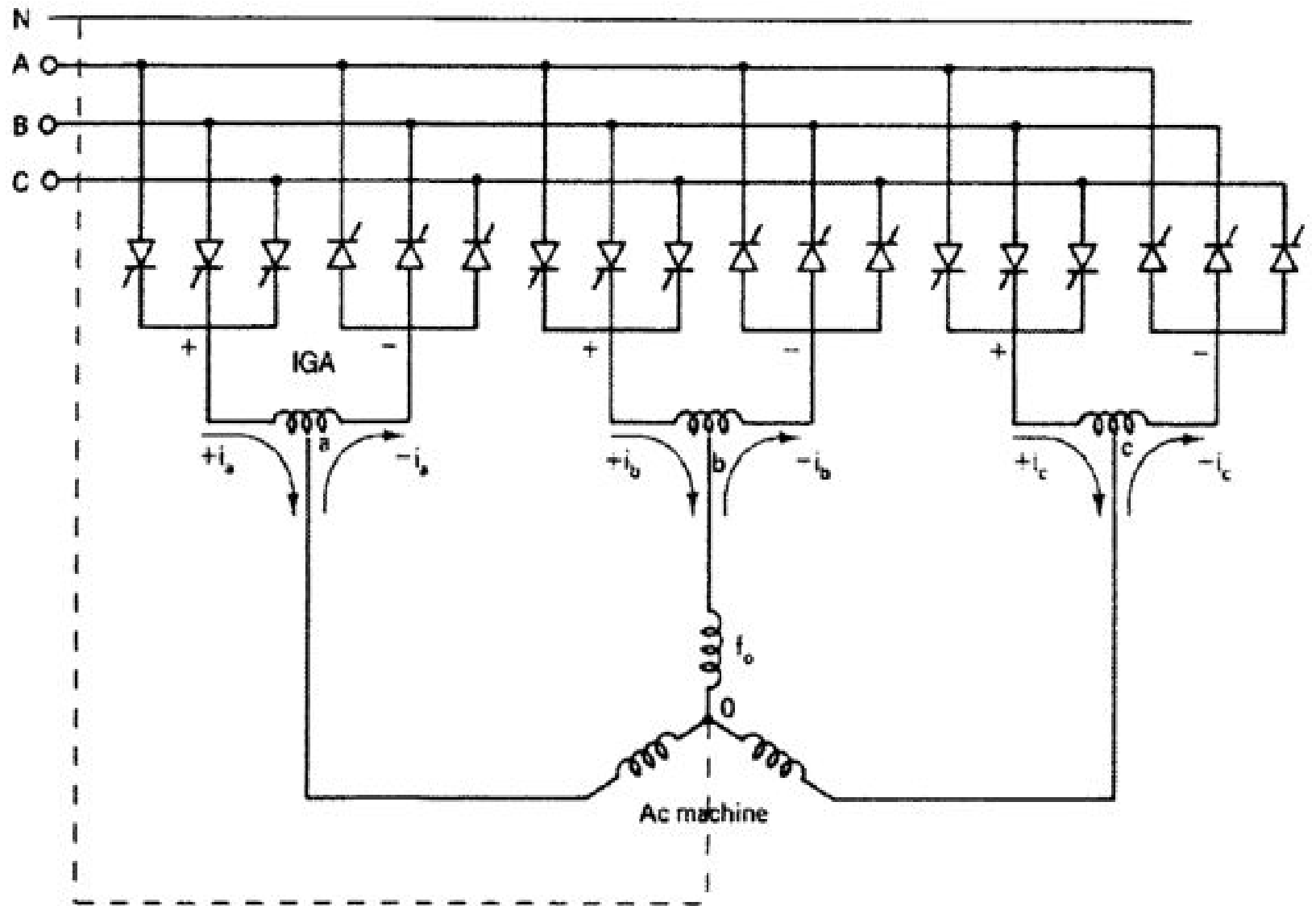

Each phase group functions as a dual converter but the firing angle of each group is modulated sinusoidally with $2\pi/3$ phase angle shift \rightarrow 3Φ balanced voltage at the motor terminal. An inter-group reactor (IGR) is connected to each phase to restrict circulating current. An output phase wave is achieved by sinusoidal modulation of the thyristor firing angles.

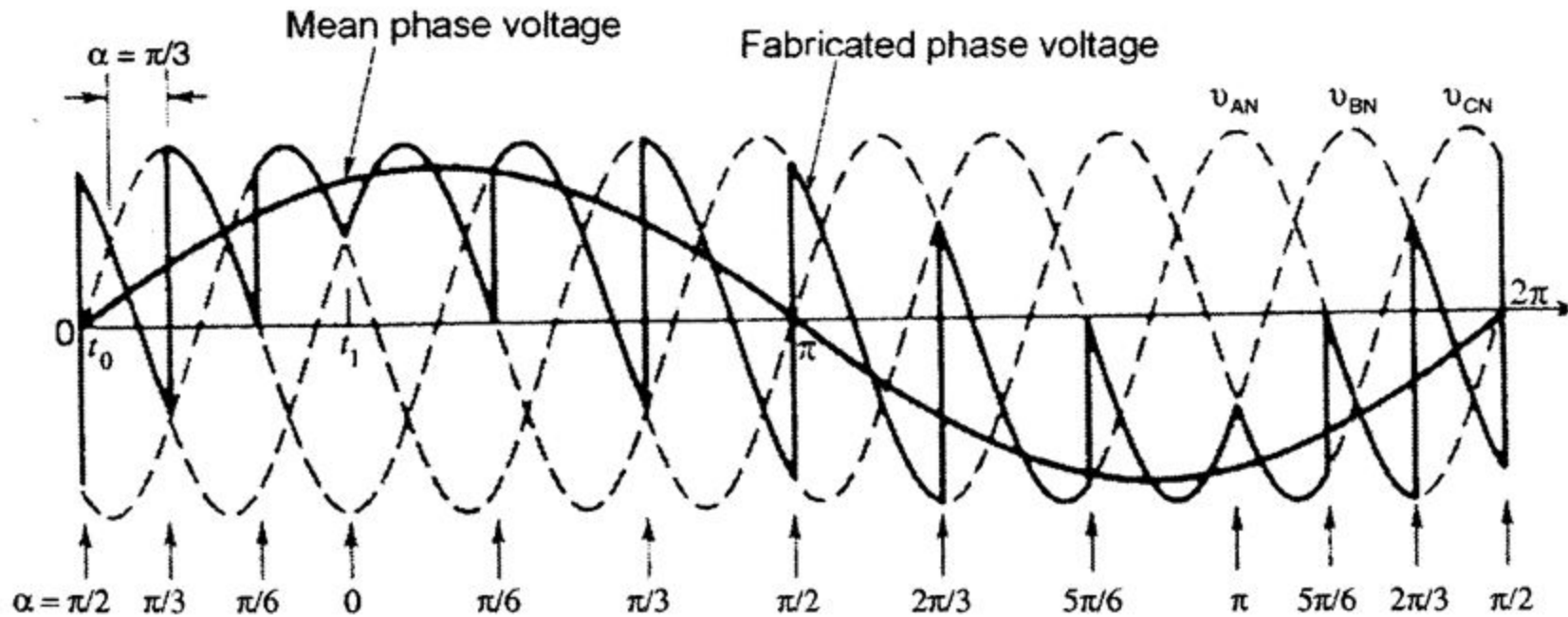

A variable voltage, variable frequency motor drive signal can be achieved by adjusting the modulation depth and output frequency of the converter.

Cycloconverter Circuits for Three-phase Output

A 3Φ to 3Φ bridge cycloconverter (widely used in multi-MW applications) can be implemented using 36 thyristors as shown below:

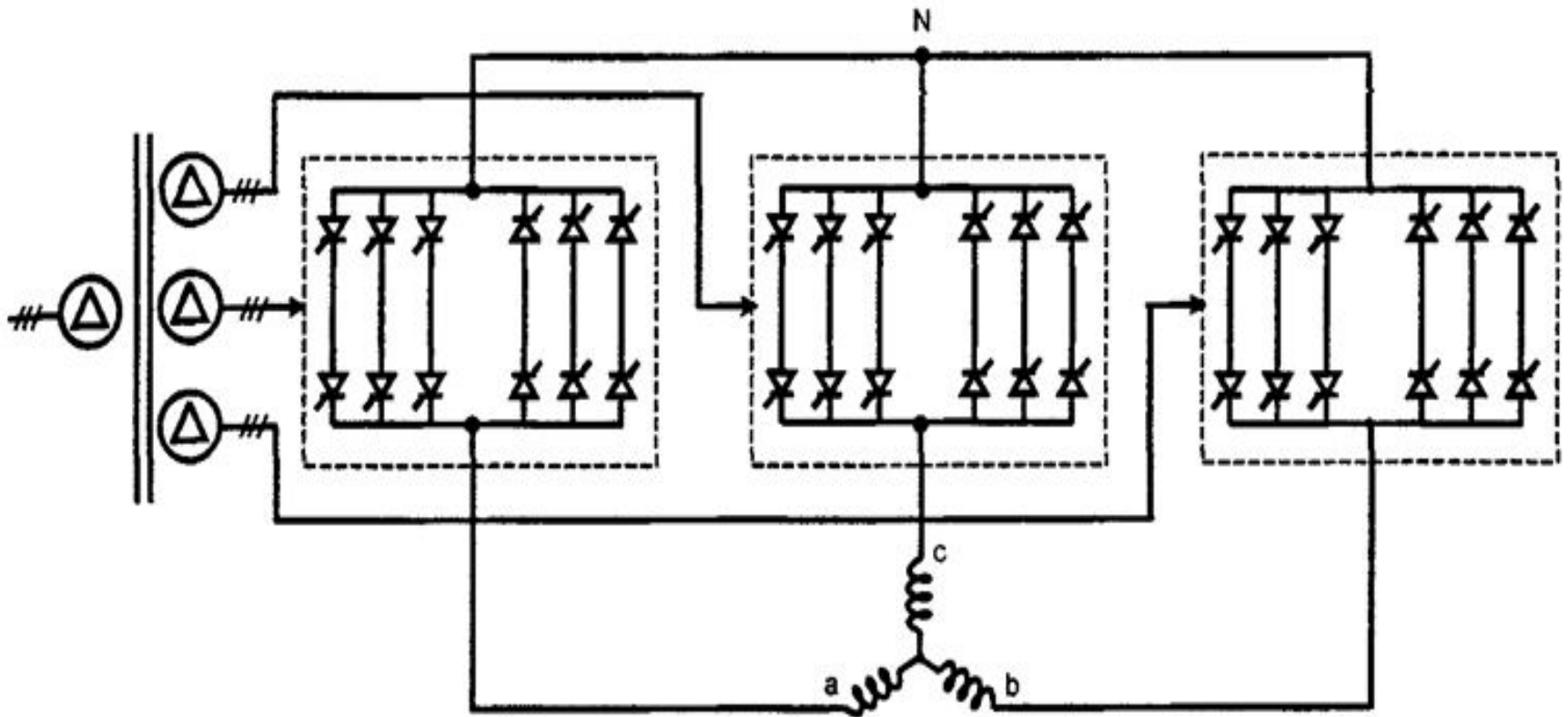

The output phase voltage v_0 can be written as:

$$v_0 = \sqrt{2}V_0 \sin \omega_0 t$$

where V_0 is the rms output voltage and ω_0 is the output angular frequency. We can also write:

$$v_0 = V_{d0} \cos \alpha_p = -V_{d0} \cos \alpha_n = m_f V_{d0} \sin \omega_0 t$$

where the **modulation factor**, m_f is given by:

$$m_f = \sqrt{2}V_0 / V_{d0}$$

From these equations, we can write:

$$\alpha_p = \cos^{-1}[m_f \sin \omega_0 t]$$

and
$$\alpha_N = \pi - \alpha_p$$

Thus for zero output voltage, $m_f=0$ and $\alpha_p = \alpha_N = \pi/2$.

For max. phase voltage, $m_f=1 \Rightarrow \alpha_p=0, \alpha_N = \pi$. See below figure

for α_p and α_N values for $m_f=0.5$ and 1.

The phase group of a cycloconverter can be operated in two modes:

- 1) Circulating current mode
- 2) Non-circulating current (blocking) mode

In the circulating current mode, the current continuously circulates between the +ve and -ve converters. Although the fundamental output voltage waves of the individual converters are equal, the harmonics will cause potential difference which will result in short-circuits without an IGR