

Voltage Control of Inverters

- Commonly-used Techniques
 - Single-Pulse-Width-Modulation
 - Multiple-Pulse-Width-Modulation
 - Sinusoidal-Pulse-Width-Modulation
 - Modified-Sinusoidal-Pulse-Width-Modulation
 - Phase-Displacement Control

Single-Pulse-Width-Modulation

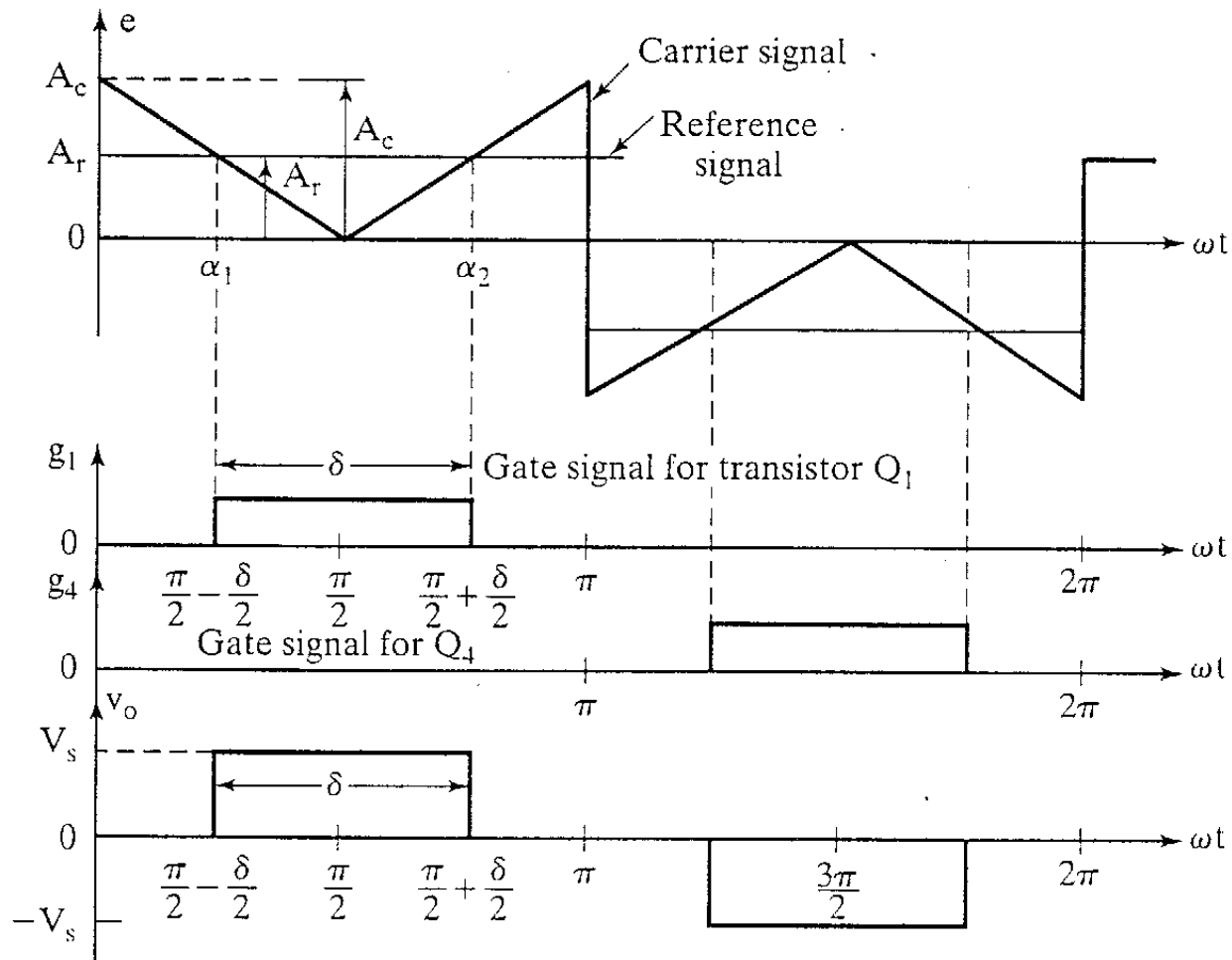

One Pulse per Half-Cycle Pulse Width Controls the Output Voltage

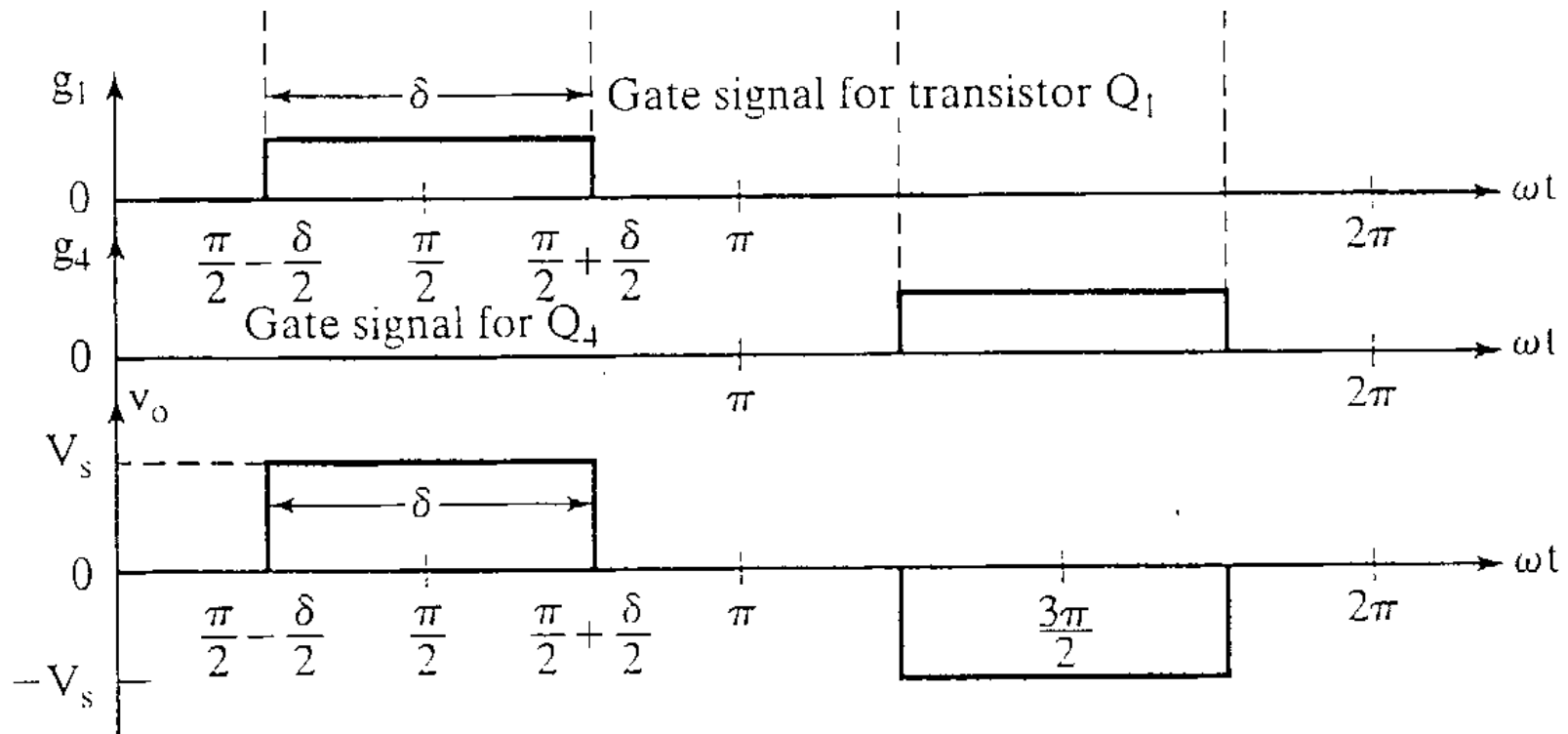

Carrier and Reference Signals

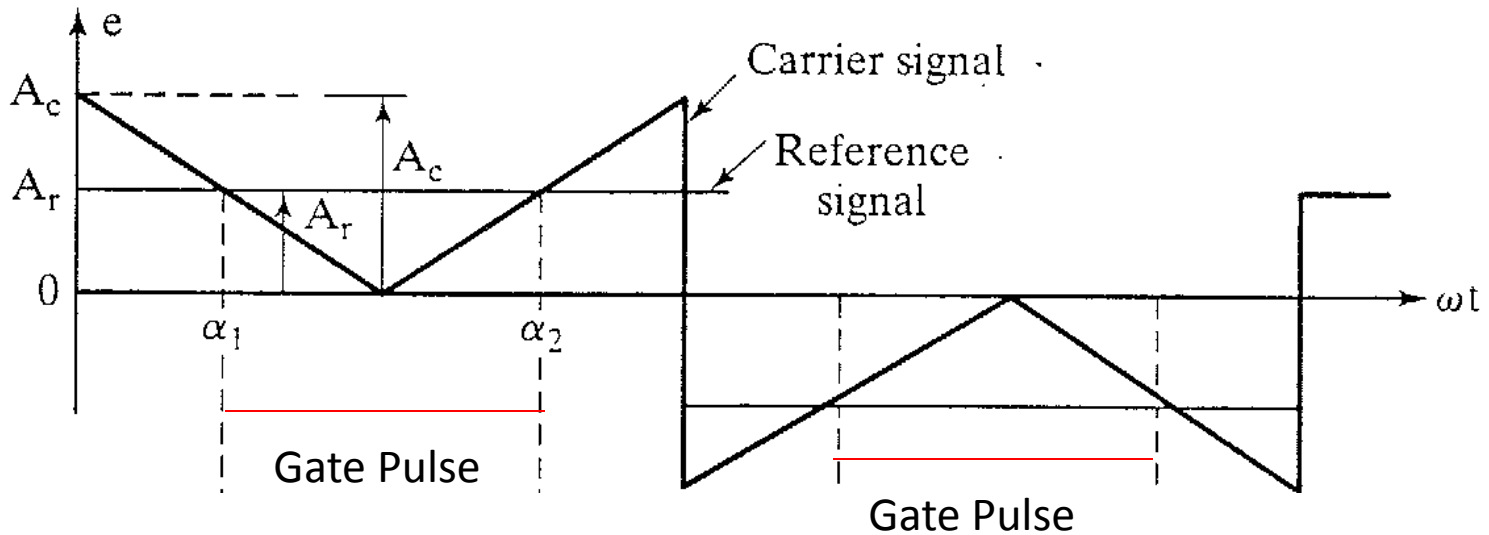

- Compare the Reference Signal with the Carrier
- Frequency of the Reference Signal determines the frequency of the Output Voltage
- Modulation Index = $M = A_r/A_c$

Gate Signals and Output

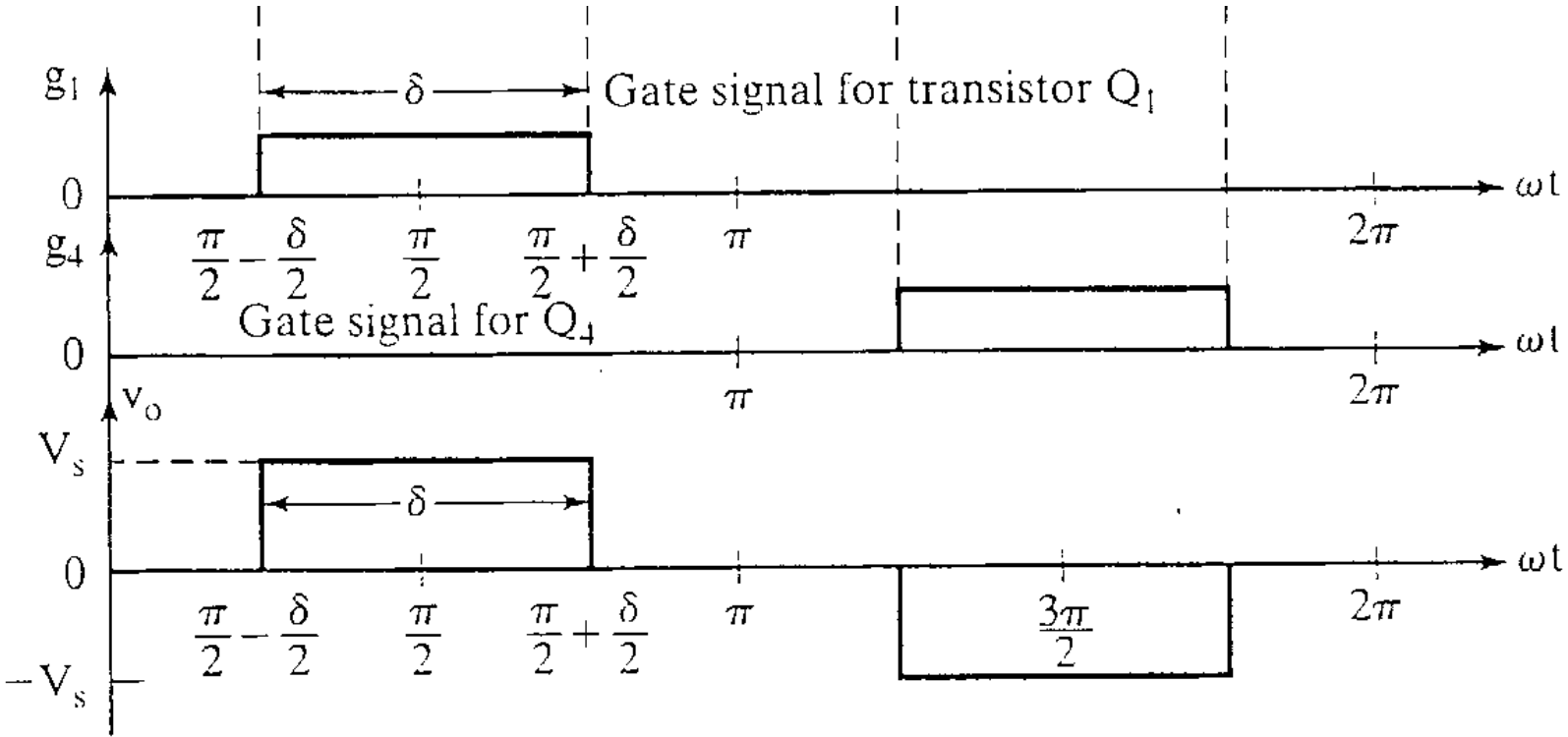

rms value of the Output Voltage

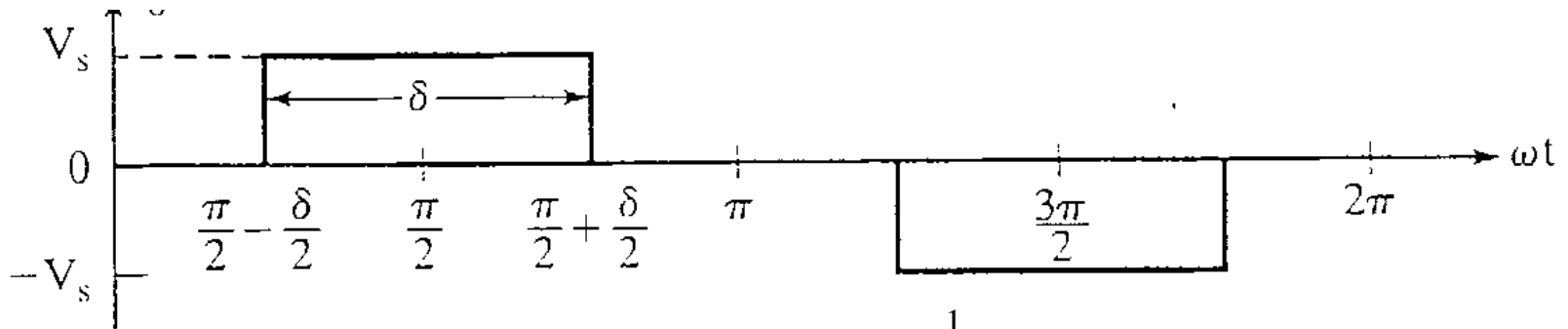

$$V_o = \left[\frac{2}{2\pi} \int_{\frac{\pi-\delta}{2}}^{\frac{\pi+\delta}{2}} V_s^2 d(\omega t) \right]^{\frac{1}{2}}$$

$$V_o = V_s \sqrt{\frac{\delta}{\pi}}$$
$$0^\circ \leq \delta \leq 180^\circ$$
$$0 \leq V_o \leq V_s$$

Fourier Series for the Output Voltage

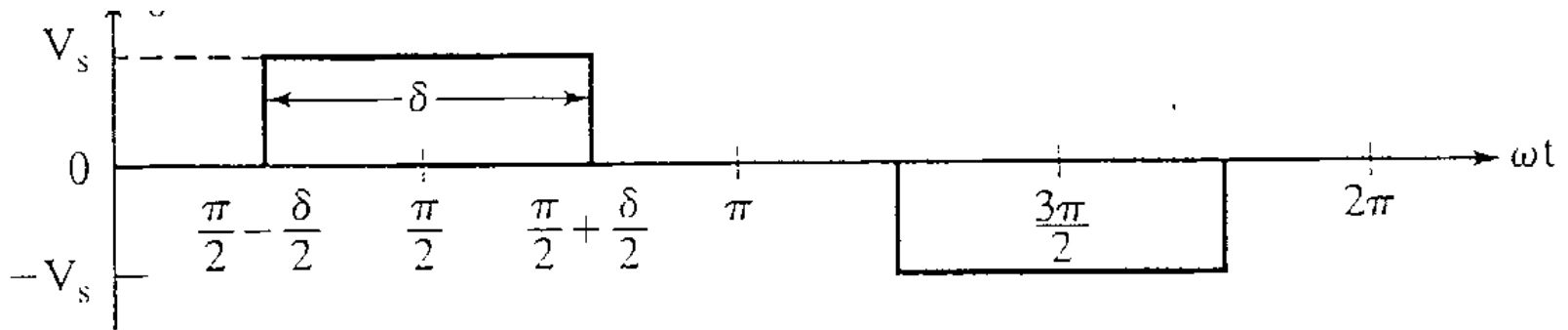

$$v_o(t) = \sum_{n=1,3,5,\dots}^{\infty} \frac{4V_s}{n\pi} \sin \frac{n\delta}{2} \sin n\omega t$$

Times and angles of the intersections

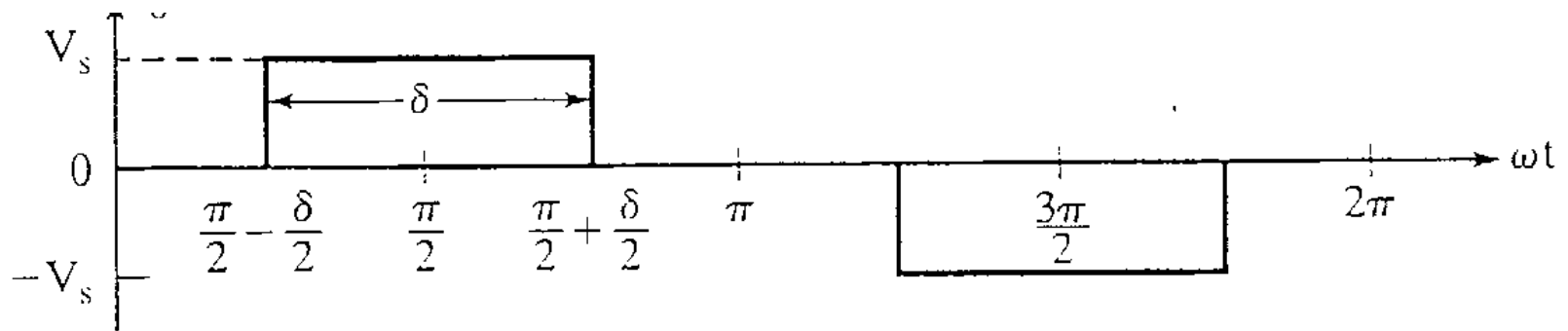

$$t_1 = \frac{\alpha_1}{\omega} = (1 - M) \frac{T_s}{2}$$

$$t_2 = \frac{\alpha_2}{\omega} = (1 + M) \frac{T_s}{2}$$

Pulse width d (or pulse angle δ)

$$T_s = T/2$$

$$d = \frac{\delta}{\omega} = t_2 - t_1 = MT_s$$

Harmonic Profile

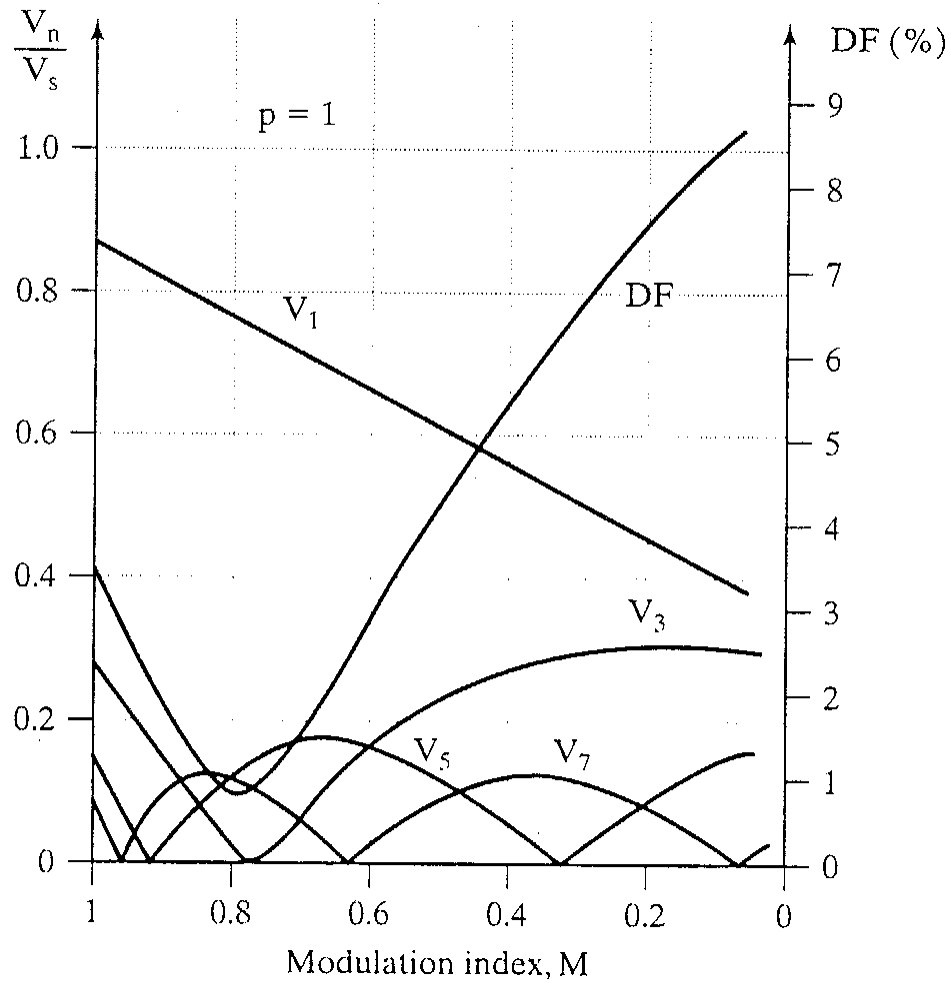

Multiple-Pulse-Width-Modulation

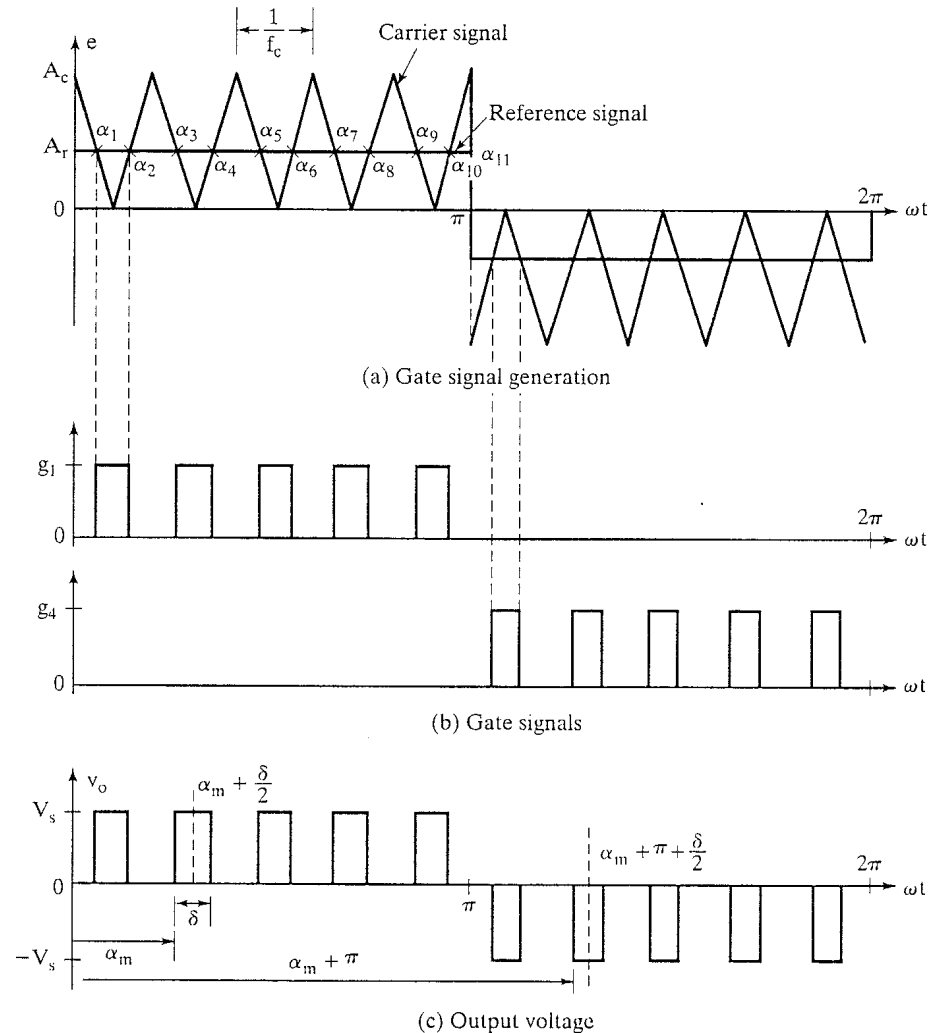

Multiple Pulses per Half-Cycle Output Voltage

of

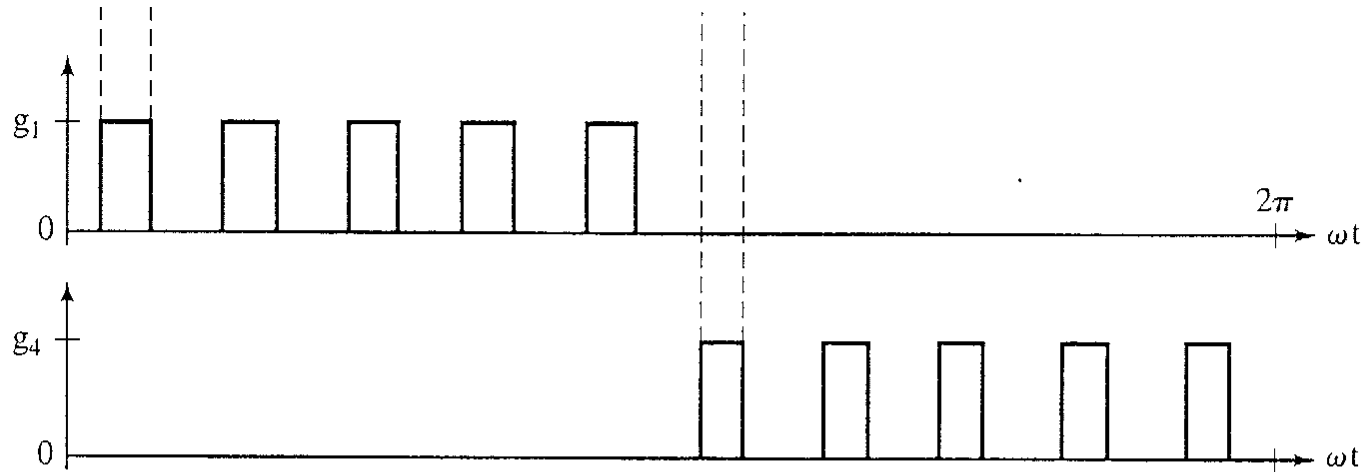

(b) Gate signals

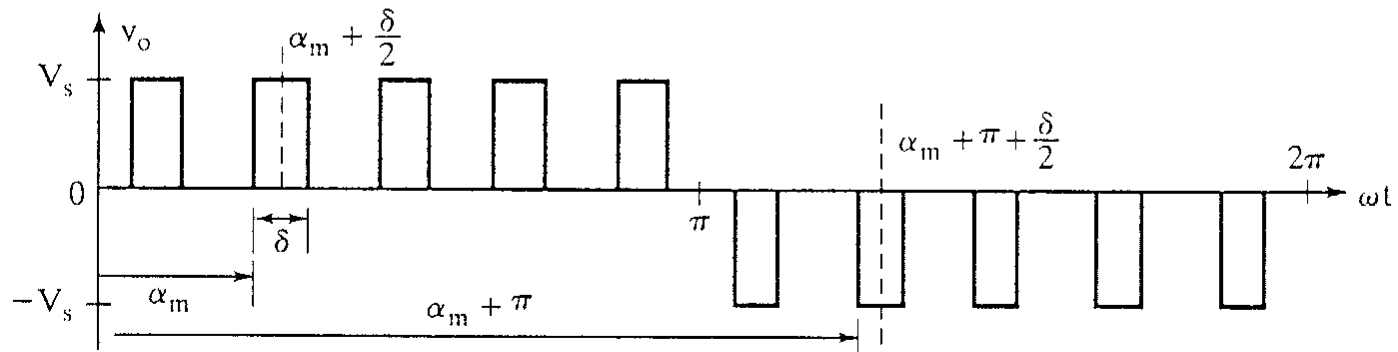

(c) Output voltage

Gate Signal Generation

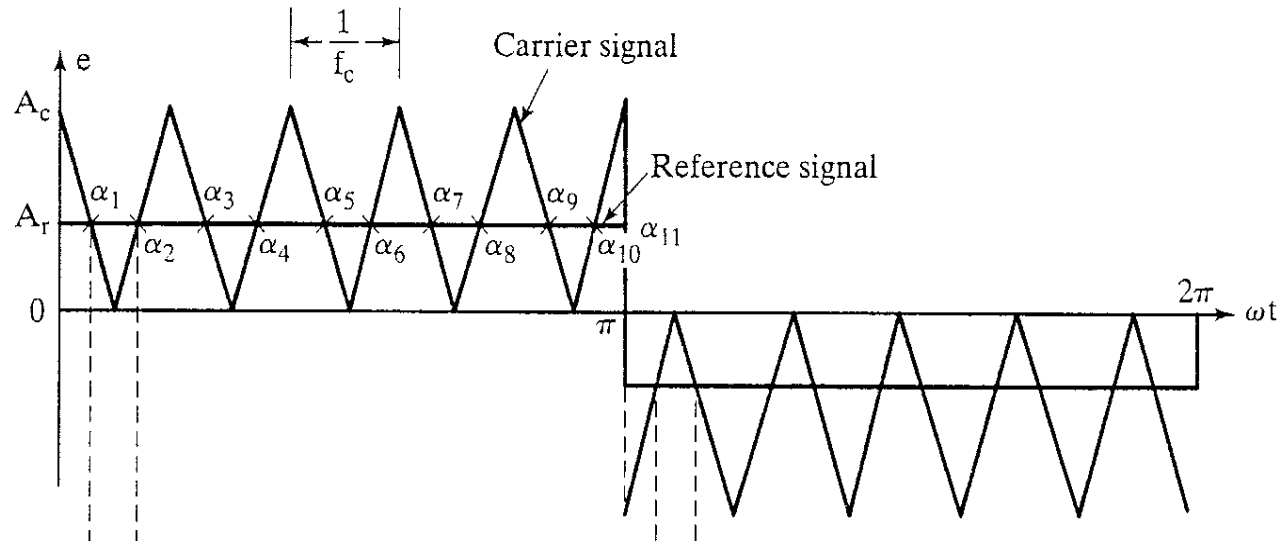

- Compare the Reference Signal with the Carrier
- Frequency of the Reference Signal determines the Output Voltage Frequency
- Frequency of the Carrier determines the number of pulses per half-cycle
- Modulation Index controls the Output Voltage

Gate Signals and Output Voltage

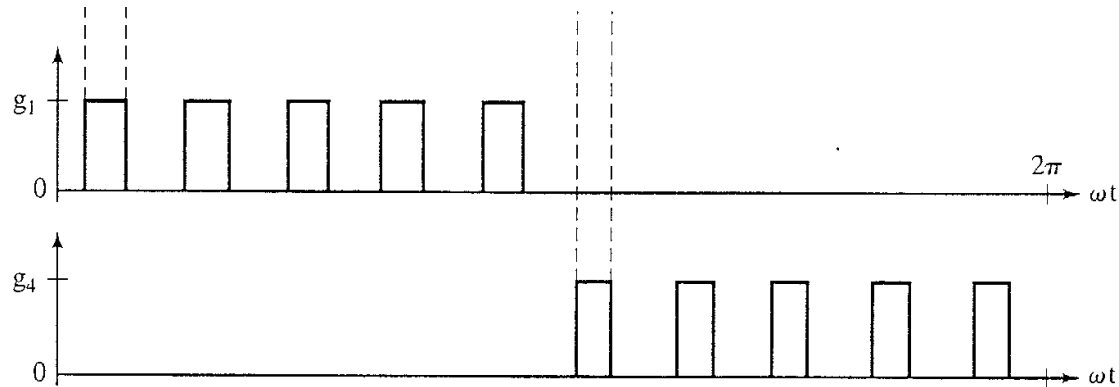

(b) Gate signals

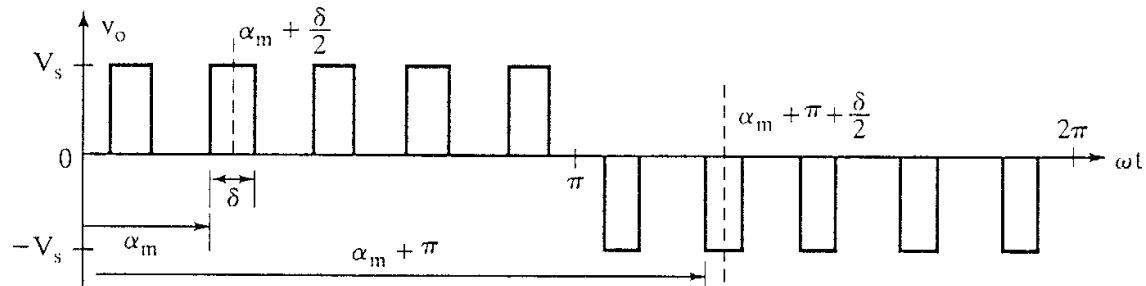

(c) Output voltage

Number of pulses per half cycle = $p = f_c/2f_o = m_f/2$
 where m_f = frequency modulation ratio

rms Value of the Output Voltage

$$V_o = \left[\frac{2p}{2\pi} \int_{(\frac{\pi-\delta}{p})/2}^{(\frac{\pi+\delta}{p})/2} V_s^2 d(\omega t) \right]^{\frac{1}{2}}$$

$$V_o = V_s \sqrt{\frac{p\delta}{\pi}}$$

$$0 \leq M \leq 1$$

$$0 \leq \delta \leq \frac{T}{2p}$$

$$0 \leq \delta \leq \frac{\pi}{p}$$

$$0 \leq V_o \leq V_s$$

Fourier Series of the Output Voltage

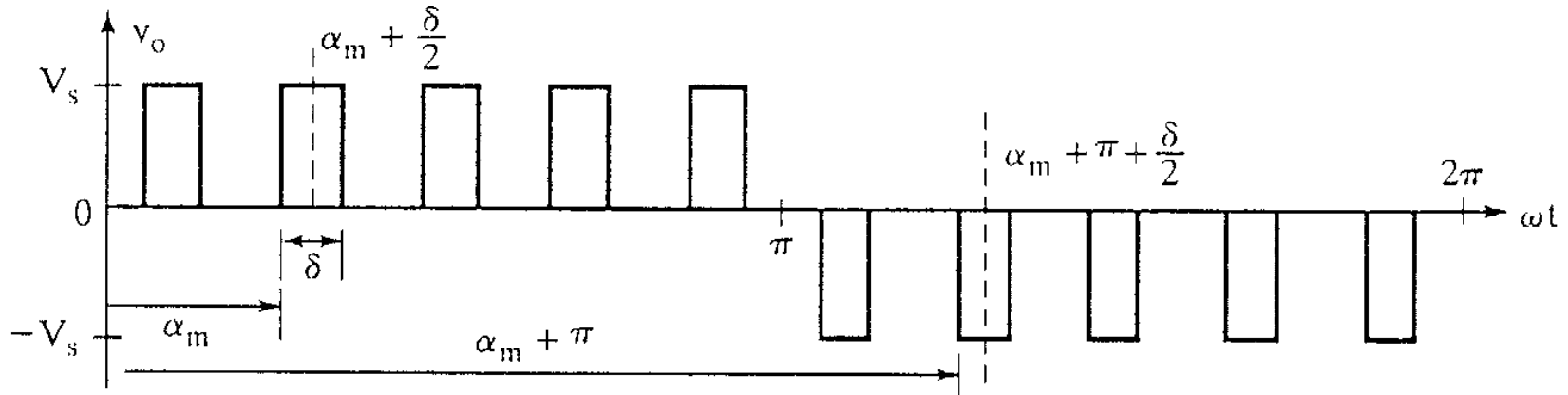

$$v_o(t) = \sum_{n=1,3,5,\dots}^{\infty} B_n \sin n\omega t$$

$$B_n = \sum_{m=1}^{2p} \frac{4V_s}{n\pi} \sin \frac{n\delta}{4} \left[\sin n\left(\alpha_m + \frac{3\delta}{4}\right) - \sin n\left(\pi + \alpha_m + \frac{\delta}{4}\right) \right]$$

The times and angles of the intersections

$$t_m = \frac{\alpha_m}{\omega} = (m - M) \frac{T_s}{2}$$

$$t_m = \frac{\alpha_m}{\omega} = (m - 1 + M) \frac{T_s}{2}$$

The pulse width d (or pulse angle δ) $T_s = T/2p$

$$d = \frac{\delta}{\omega} = t_{m+1} - t_m = MT_s$$

Harmonic Profile

