

Encoding and Modulation Techniques

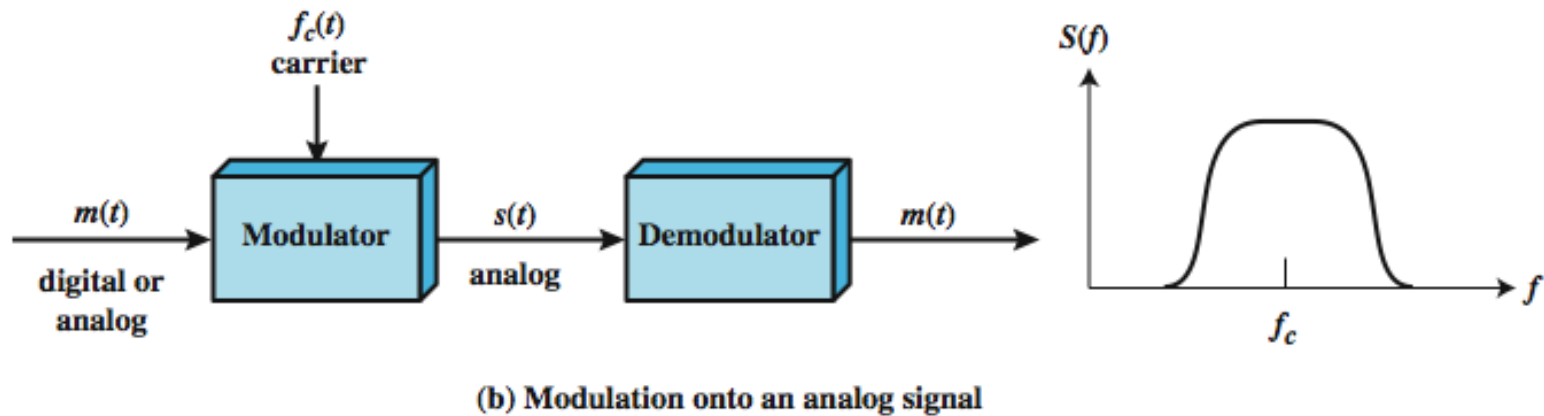
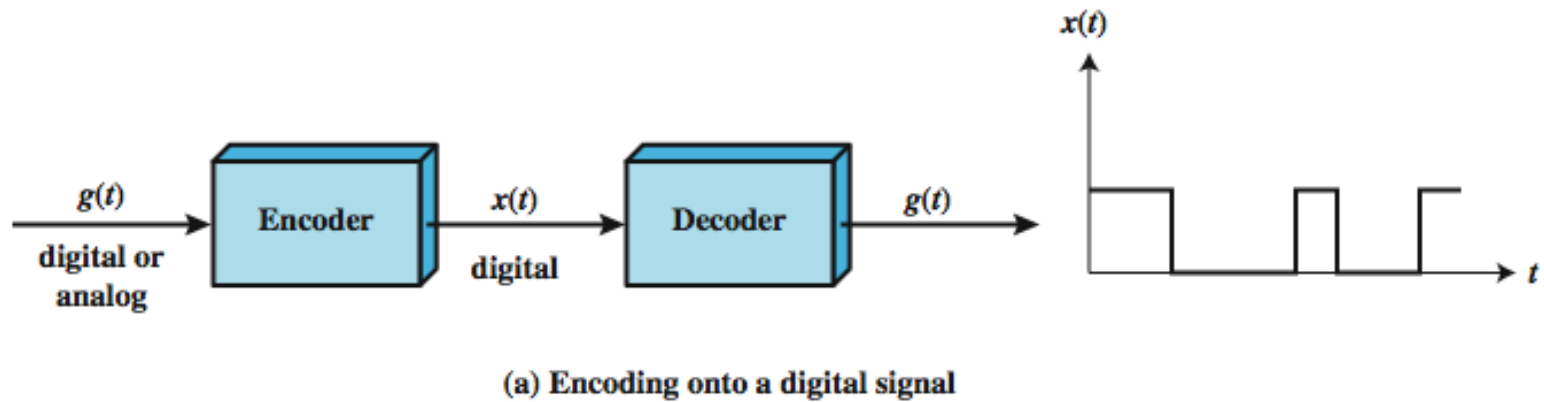

Figure 5.1 Encoding and Modulation Techniques

Digital Signaling Versus Analog Signaling

❑ Digital signaling

- **Digital or analog data** is encoded into a digital signal
- Encoding may be chosen to conserve bandwidth or to minimize error

❑ Analog Signaling

- **Digital or analog data** modulates analog carrier signal
- The frequency of the carrier f_c is chosen to be compatible with the transmission medium used
- Modulation: the amplitude, frequency or phase of the carrier signal is varied in accordance with the modulating data signal
- by using different carrier frequencies, multiple data signals (users) can share the same transmission medium

Digital Signaling

□ Digital data, digital signal

- Simplest encoding scheme: assign one voltage level to binary one and another voltage level to binary zero
- More complex encoding schemes: are used to improve performance (reduce transmission bandwidth and minimize errors).
- Examples are NRZ-L, NRZI, Manchester, etc.

□ Analog data, Digital signal

- Analog data, such as voice and video
- Often digitized to be able to use digital transmission facility
- Example: Pulse Code Modulation (PCM), which involves **sampling** the analog data periodically and **quantizing** the samples

Analog Signaling

❑ Digital data, Analog Signal

- A modem converts digital data to an analog signal so that it can be transmitted over an analog line
- The digital data modulates the amplitude, frequency, or phase of a carrier analog signal
- Examples: Amplitude Shift Keying (ASK), Frequency Shift Keying (FSK), Phase Shift Keying (PSK)

❑ Analog data, Analog Signal

- Analog data, such as voice and video modulate the amplitude, frequency, or phase of a carrier signal to produce an analog signal in a different frequency band
- Examples: Amplitude Modulation (AM), Frequency Modulation (FM), Phase Modulation (PM)

Digital Data, Digital Signal

□ Digital signal

- discrete, discontinuous voltage pulses
- each pulse is a signal element
- binary data encoded into signal elements

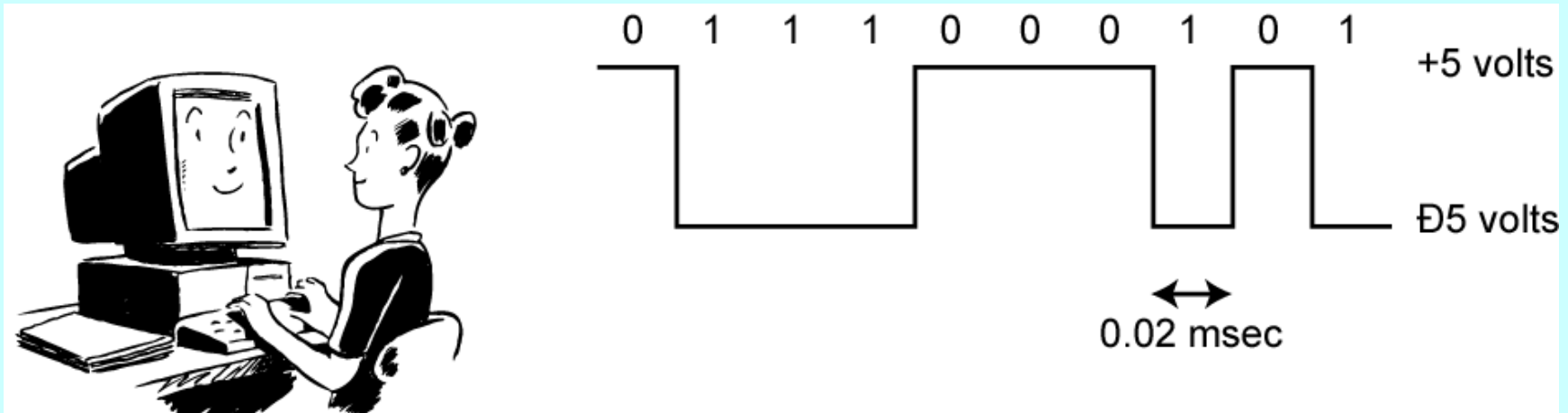

Periodic signals

- **Data element:** a single binary 1 or 0
- **Signal element:** a voltage pulse of constant amplitude
- **Unipolar:** All signal elements have the same sign
- **Polar:** One logic state represented by positive voltage the other by negative voltage
- **Data rate:** Rate of data (R) transmission in bits per second
- **Duration or length of a bit:** Time taken for transmitter to emit the bit ($T_b = 1/R$)
- **Modulation rate:** Rate at which the signal level changes, measured in baud = signal elements per second. Depends on type of digital encoding used.

Interpreting Signals

□ Need to know

- timing of bits: when they start and end
- signal levels: high or low

□ factors affecting signal interpretation

- Data rate: increase data rate increases Bit Error Rate (BER)
- Signal to Noise Ratio (SNR): increase SNR decrease BER
- Bandwidth: increase bandwidth increase data rate
- encoding scheme: mapping from data bits to signal elements

Comparison of Encoding Schemes

□ signal spectrum

- Lack of high frequencies reduces required bandwidth,
- lack of dc component allows ac coupling via transformer, providing isolation,
- should concentrate power in the middle of the bandwidth

□ Clocking

- synchronizing transmitter and receiver with a sync mechanism based on suitable encoding

□ error detection

- useful if can be built in to signal encoding

□ signal interference and noise immunity

□ cost and complexity: increases when increases data rate

Encoding Schemes

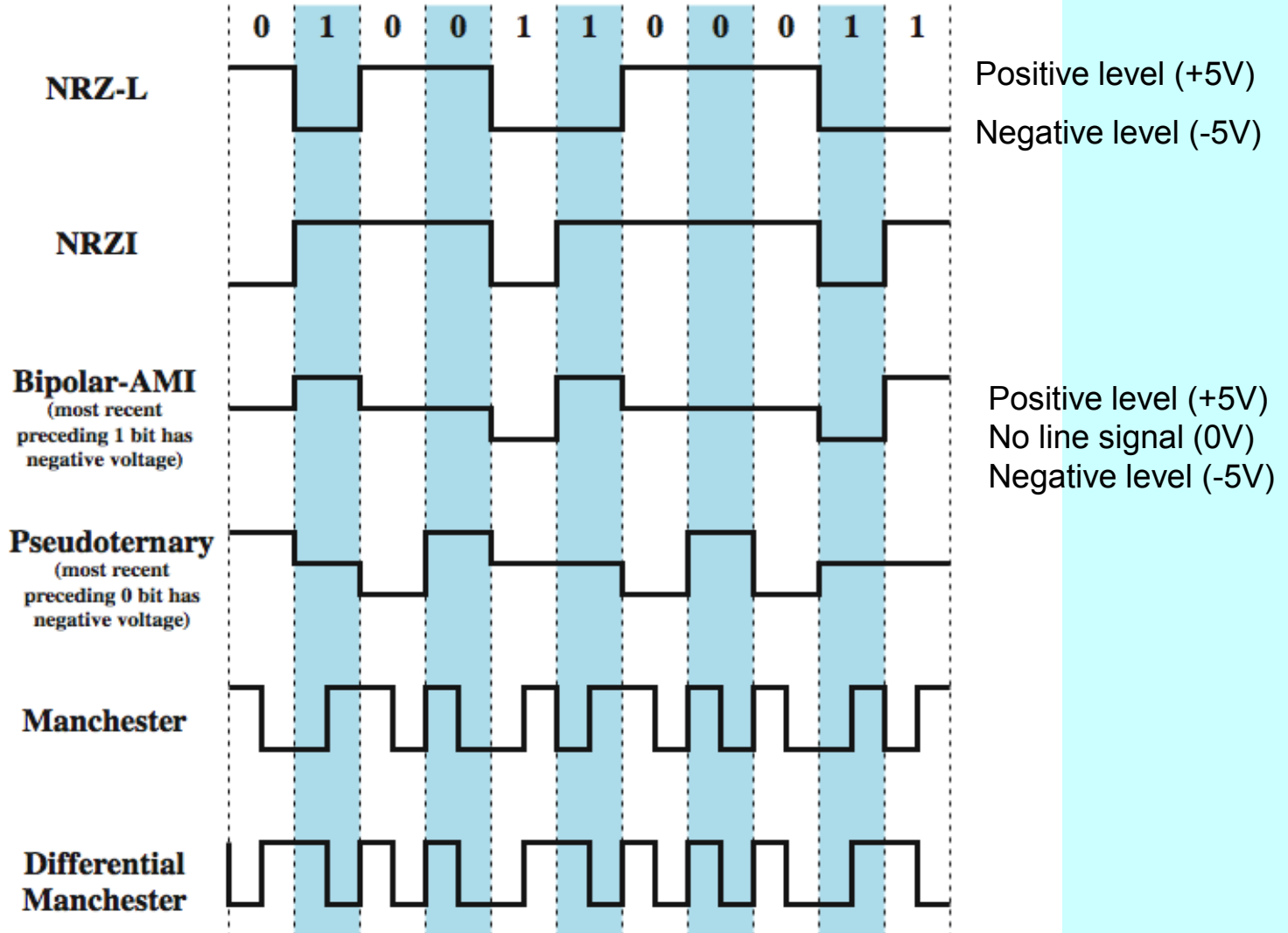

Table 5.2 Definition of Digital Signal Encoding Formats

Nonreturn to Zero-Level (NRZ-L)

0 = high level

1 = low level

Nonreturn to Zero Inverted (NRZI)

0 = no transition at beginning of interval (one bit time)

1 = transition at beginning of interval

Bipolar-AMI

0 = no line signal

1 = positive or negative level, alternating for successive ones

Pseudoternary

0 = positive or negative level, alternating for successive zeros

1 = no line signal

Manchester

0 = transition from high to low in middle of interval

1 = transition from low to high in middle of interval

Differential Manchester

Always a transition in middle of interval

0 = transition at beginning of interval

1 = no transition at beginning of interval

B8ZS

Same as bipolar AMI, except that any string of eight zeros is replaced by a string with two code violations

HDB3

Same as bipolar AMI, except that any string of four zeros is replaced by a string with one code violation

NonReturn to Zero-Level (NRZ-L)

- ❑ Two different voltages for 0 and 1 bits
- ❑ Voltage constant during bit interval
 - no transition, i.e. no return to zero voltage
 - more often, negative voltage for binary one and positive voltage for binary zero

NonReturn to Zero **INVERTED** (NRZI)

- ❑ Nonreturn to zero inverted on ones
- ❑ Constant voltage pulse for duration of bit
- ❑ Data encoded as presence or absence of signal transition at beginning of bit time
 - transition (low to high or high to low) denotes binary 1
 - no transition denotes binary 0
- ❑ Example of differential encoding since have
 - data represented by changes rather than levels
 - more reliable detection of transition rather than level

Advantages and disadvantages of NRZ-L, NRZI

Advantages

- easy to engineer
- good use of bandwidth

Disadvantages

- dc component
- lack of synchronization capability

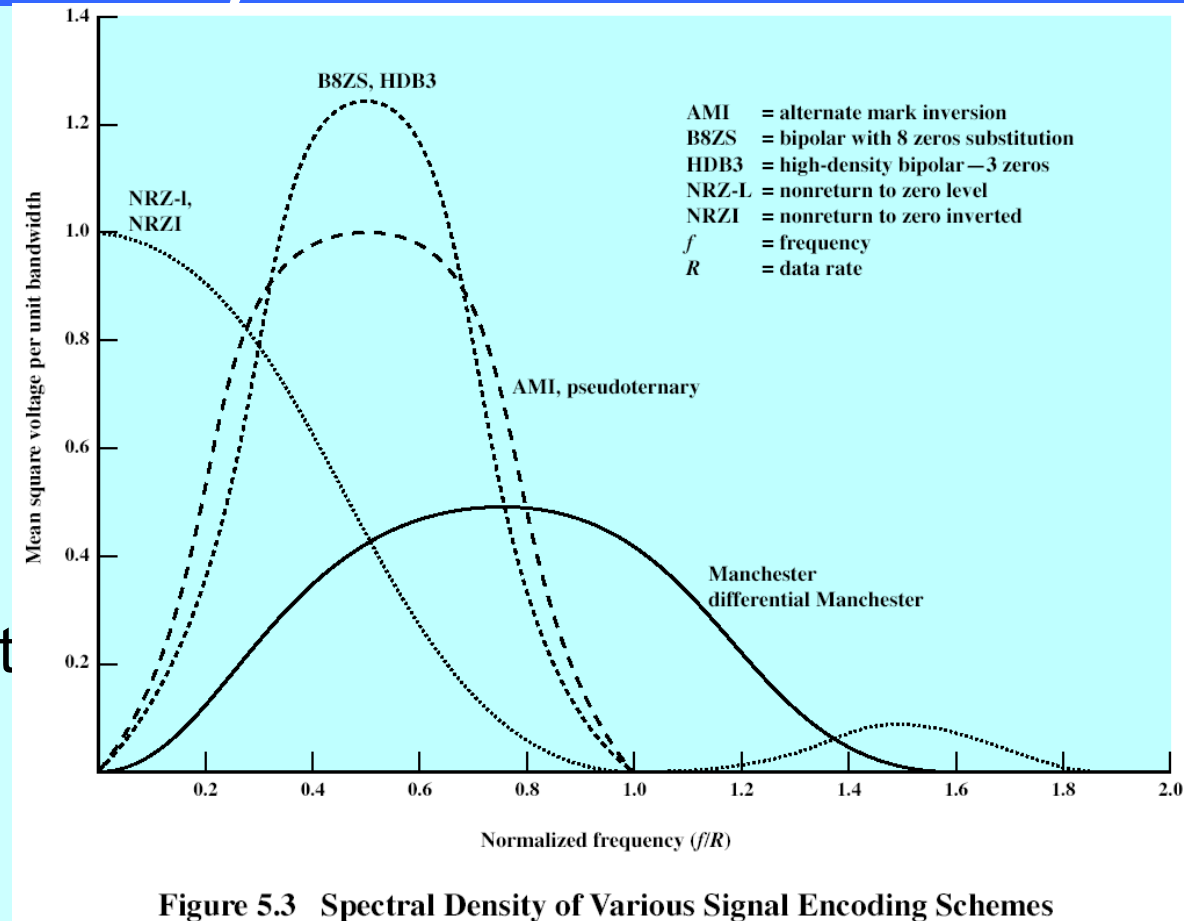

Unattractive for signal transmission applications

Multilevel Binary

Bipolar Alternate Mark Inversion (AMI)

- ❑ Use more than two levels (three levels, positive, negative and no line signal)
- ❑ Bipolar-AMI
 - zero represented by no line signal
 - one represented by positive or negative pulse
 - one pulses alternate in polarity
 - no loss of sync if a long string of ones
 - long runs of zeros still a problem
 - no net dc component
 - lower bandwidth
 - easy error detection

QAM Variants

- ❑ Two level ASK (two different amplitude levels)
 - each of two streams in one of two states
 - four state system
 - essentially QPSK
- ❑ Four level ASK (four different amplitude levels)
 - combined stream in one of 16 states
- ❑ Have 64 and 256 state systems
- ❑ Improved data rate for given bandwidth
 - but increased potential error rate