

Outline

- Overview of DS/CDMA systems
- Concept of multiuser detection (MUD)
- MUD algorithms
- Limitations of MUD
- Conclusion

DS/CDMA Systems

- A conventional DS/CDMA system treats each user separately as a signal, with other users considered as noise or MAI – multiple access interference
- Capacity is *interference-limited*
- Near/far effect: users near the BS are received at higher powers than those far away
 - those far away suffer a degradation in performance
 - Need tight power control

Multiuser Detection

- Multiuser detection considers all users as signals for each other -> joint detection
 - Reduced interference leads to capacity increase
 - Alleviates the near/far problem
- MUD can be implemented in the BS or mobile, or both
- In a cellular system, base station (BS) has knowledge of all the chip sequences
- Size and weight requirement for BS is not stringent
- Therefore MUD is currently being envisioned for the uplink (mobile to BS)

Concept of MUD

- Simplified system model (BPSK)
 - Baseband signal for the k^{th} user is:

$$u_k(t) = \sum_{i=0}^{\infty} x_k(i) \cdot c_k(i) \cdot s_k(t - iT - \tau_k)$$

- $x_k(i)$ is the i^{th} input symbol of the k^{th} user
- $c_k(i)$ is the real, positive channel gain
- $s_k(t)$ is the signature waveform containing the PN sequence
- τ_k is the transmission delay; for synchronous CDMA, $\tau_k=0$ for all users

- Received signal at baseband

$$y(t) = \sum_{k=1}^K u_k(t) + z(t)$$

- K number of users
- $z(t)$ is the complex AWGN

Concept of MUD (2)

- Sampled output of the matched filter for the k^{th} user:

$$\begin{aligned}y_k &= \int_0^T y(t) s_k(t) dt \\ &= c_k x_k + \sum_{j \neq k}^K x_j c_j \int_0^T s_k(t) s_j(t) dt + \int_0^T s_k(t) z(t) dt\end{aligned}$$

- 1st term - desired information
 - 2nd term - MAI
 - 3rd term - noise
- Assume two-user case ($K=2$), and

$$r = \int_0^T s_1(t) s_2(t) dt$$

Concept of MUD (3)

- Outputs of the matched filters are:

$$y_1 = c_1 x_1 + r c_2 x_2 + z_1 \quad y_2 = c_2 x_2 + r c_1 x_1 + z_2$$

- Detected symbol for user k: $\hat{x}_k = \text{sgn}(y_k)$
- If user 1 is much stronger than user 2 (the near/far problem), the MAI term $r c_1 x_1$ present in the signal of user 2 is very large

- Successive Interference Cancellation

- decision is made for the stronger user 1: $\hat{x}_1 = \text{sgn}(y_1)$
- subtract the estimate of MAI from the signal of the weaker user:

$$\begin{aligned} \hat{x}_2 &= \text{sgn}(y_2 - r c_1 \hat{x}_1) \\ &= \text{sgn}(c_2 x_2 + r c_1 (x_1 - \hat{x}_1) + z_2) \end{aligned}$$

- all MAI can be subtracted from user 2 signal provided estimate is correct
- MAI is reduced and near/far problem is alleviated

MUD Algorithms

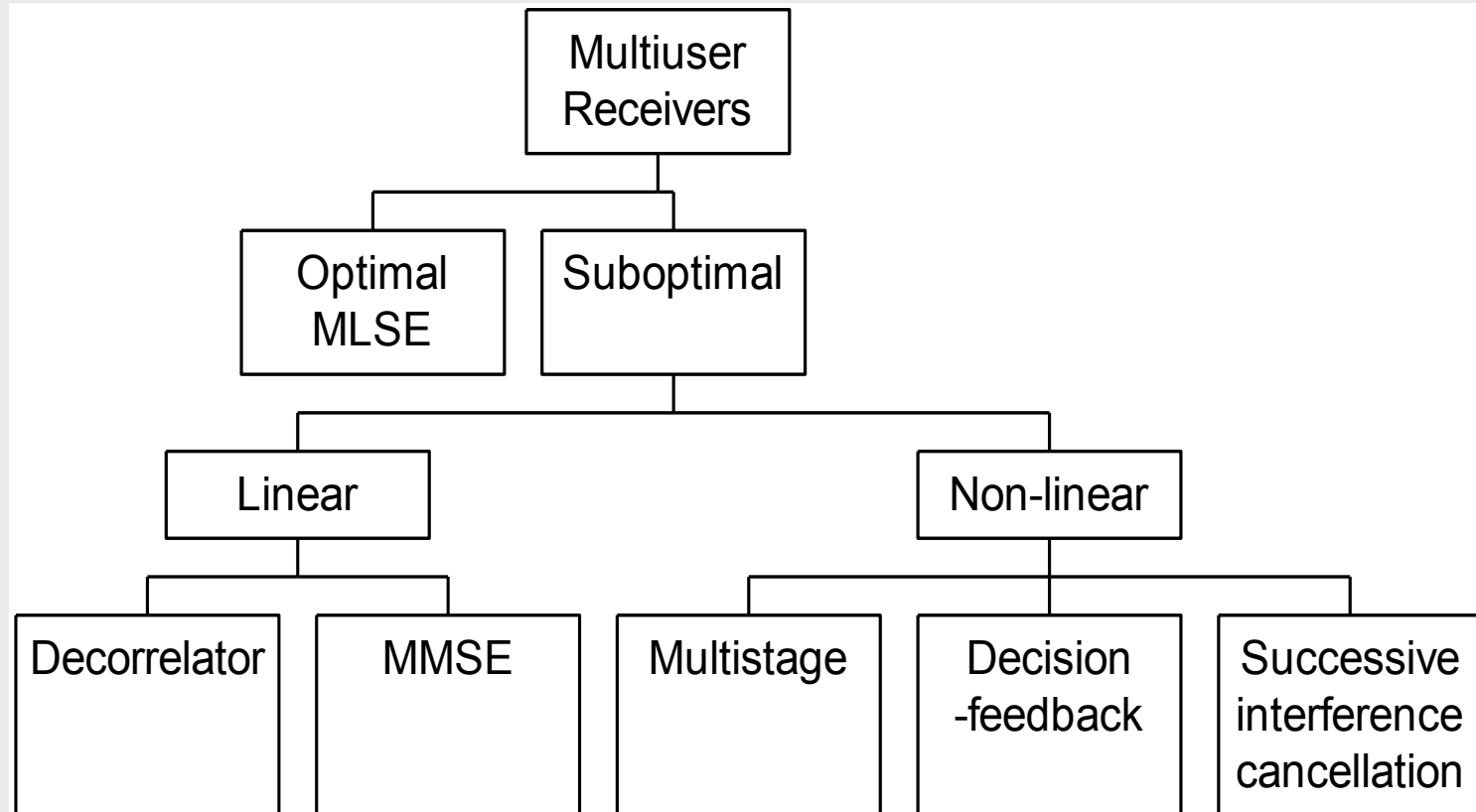

Optimal MLSE Detector

- Maximum-likelihood sequence estimation (MLSE) is the optimal detector (Verdú, 1984)
- For synchronous CDMA, search over 2^K possible combinations of the bits in vector x

$$\hat{x} = \arg \left\{ \max_{x \in \{-1, +1\}^K} \left[2y^T Wx - b^T W R W b \right] \right\}$$

- For asynchronous CDMA, use Viterbi algorithm with 2^{K-1} states
- Both too complex for practical implementation

Decorrelator

- Matrix representation

$$\underline{y} = RW \underline{x} + \underline{z}$$

- where $\underline{y} = [y_1, y_2, \dots, y_K]^T$, R and W are $K \times K$ matrices
- Components of R are given by cross-correlations between signature waveforms $s_k(t)$
- W is diagonal with component $W_{k,k}$ given by the channel gain c_k of the k^{th} user
- \underline{z} is a colored Gaussian noise vector
- Solve for \underline{x} by inverting R

$$\underline{\tilde{y}} = R^{-1} \underline{y} = W \underline{x} + R^{-1} \underline{z} \quad \Rightarrow \quad \hat{x}_k = \text{sgn}(\tilde{y}_k)$$

- Analogous to zero-forcing equalizers for ISI channels
- Pros: Does not require knowledge of users' powers
- Cons: Noise enhancement

Multistage Detectors

- Decisions produced by 1st stage are $\hat{x}_1(1), \hat{x}_2(1)$
- 2nd stage:
$$\hat{x}_1(2) = \text{sgn}[y_1 - rc_2 \hat{x}_2(1)]$$
$$\hat{x}_2(2) = \text{sgn}[y_2 - rc_1 \hat{x}_1(1)]$$
- and so on...

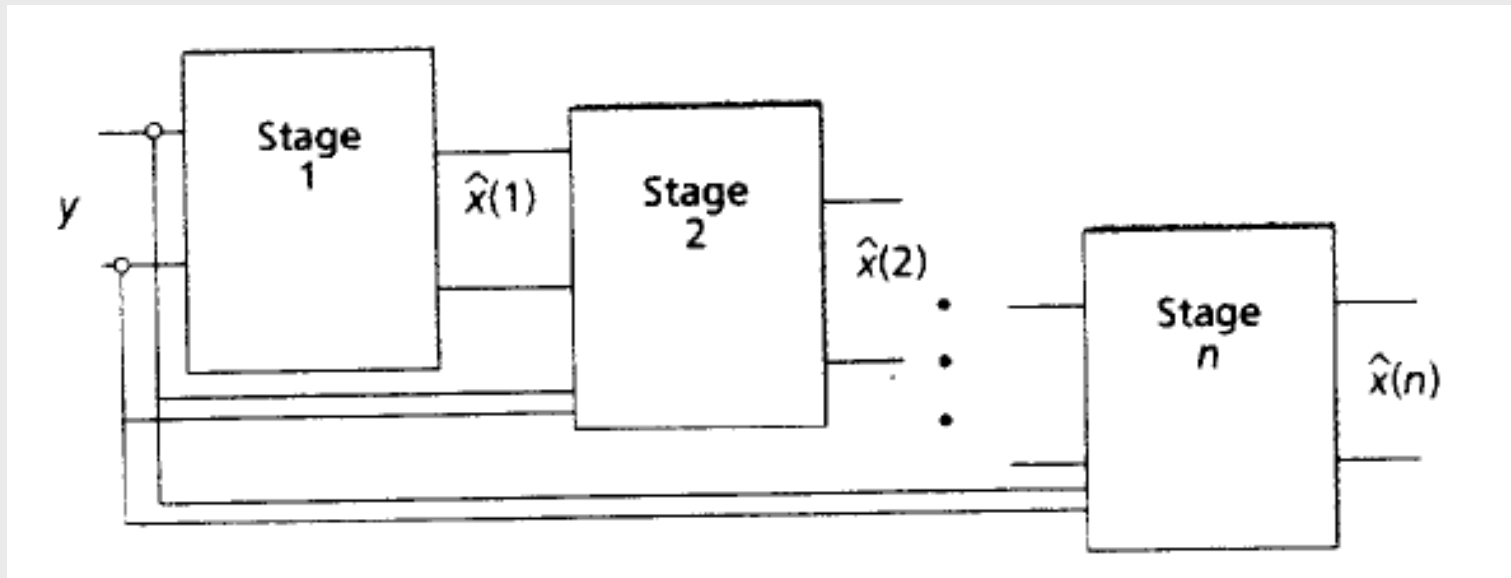

Decision-Feedback Detectors

- Characterized by two matrix transformation: forward filter and feedback filter
- Whitening filter yields a lower triangular MAI matrix
- Performance similar to that of the decorrelator

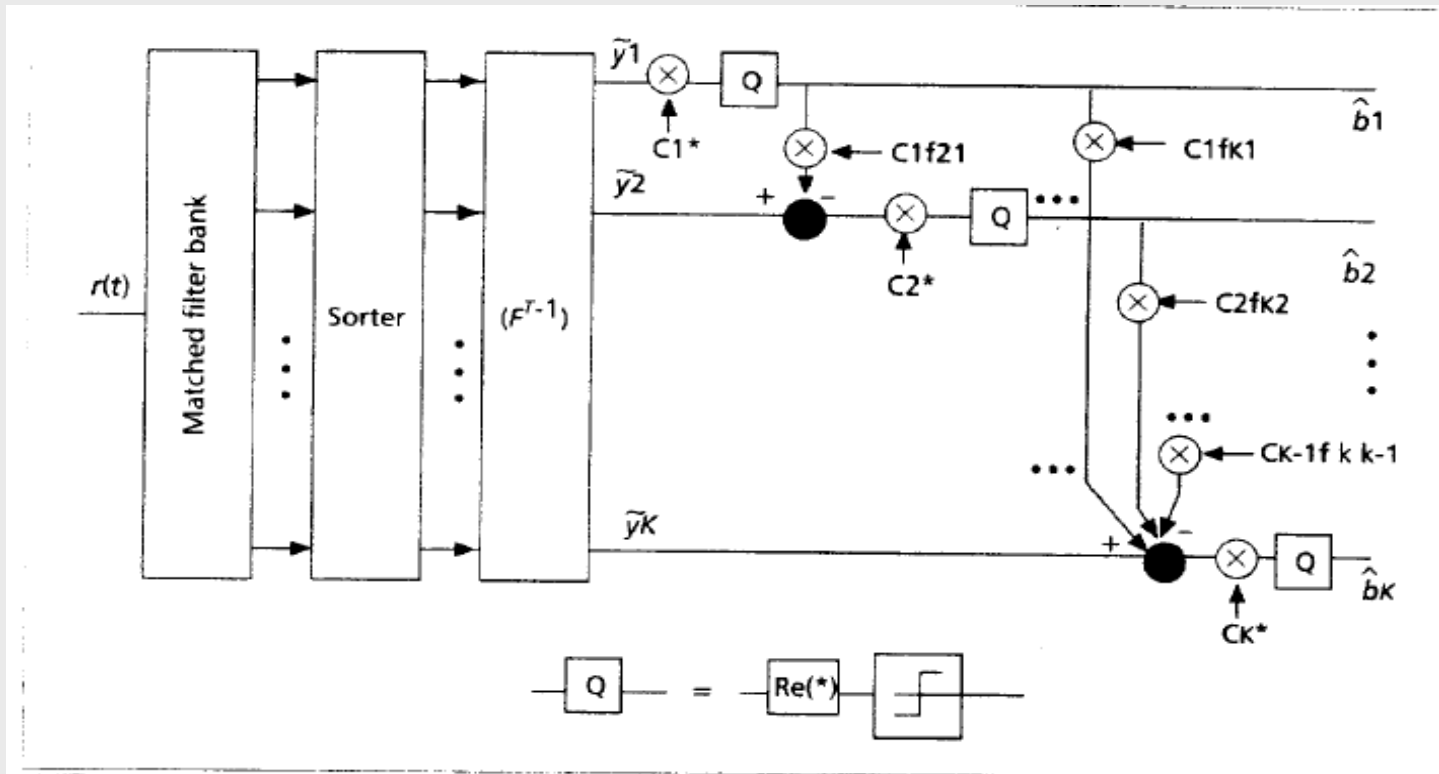

■ **Figure 4.** The decorrelating decision-feedback detector for Synchronous CDMA.

DFD Performance

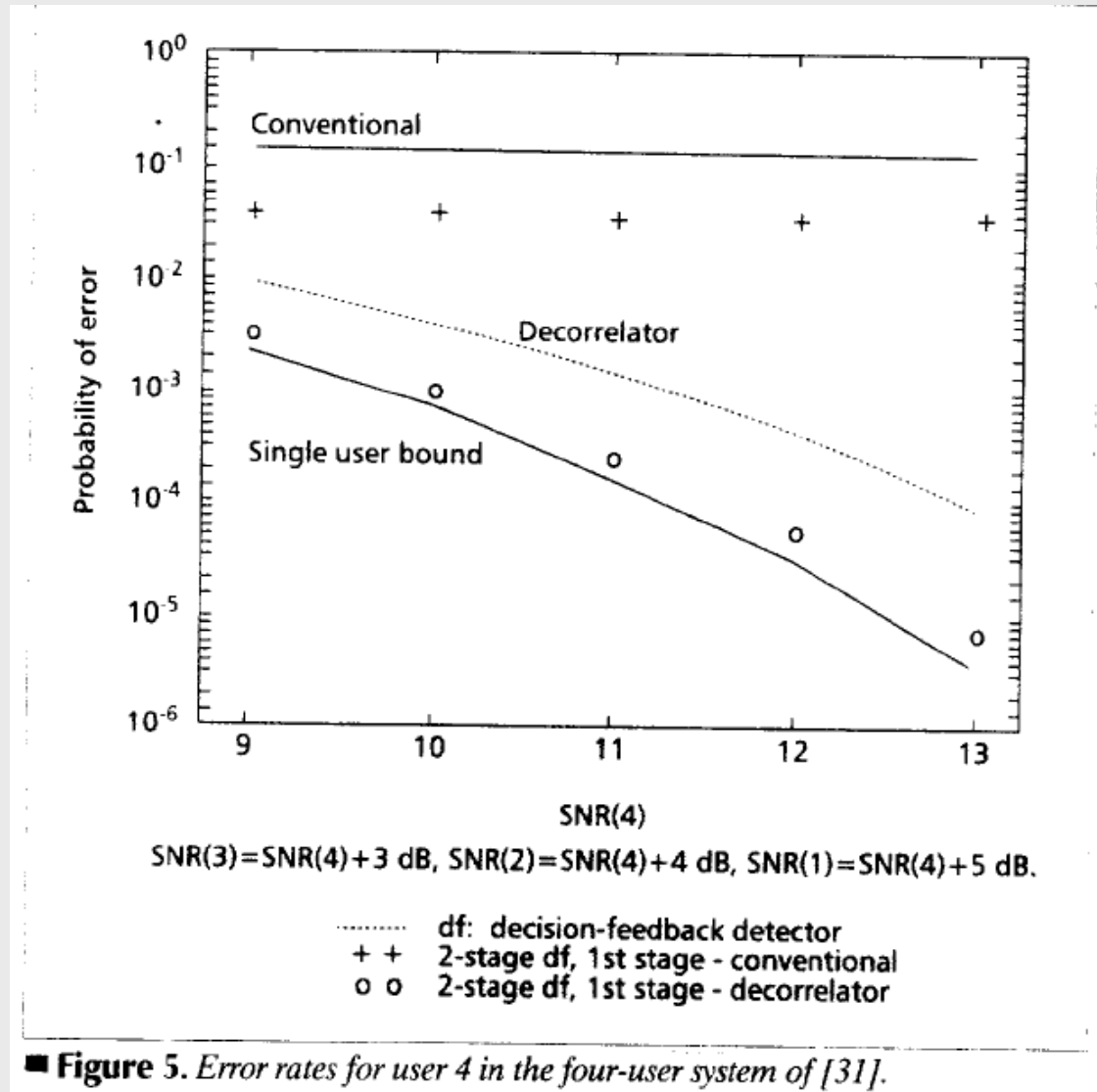

Successive Interference Cancellers

- Successively subtracting off the strongest remaining signal
 - Cancelling the strongest signal has the most benefit
 - Cancelling the strongest signal is the most reliable cancellation
- An alternative called the *Parallel Interference Cancellers* simultaneously subtract off all of the users' signals from all of the others
 - works better than SIC when all of the users are received with equal strength (e.g. under power control)

Performance of MUD

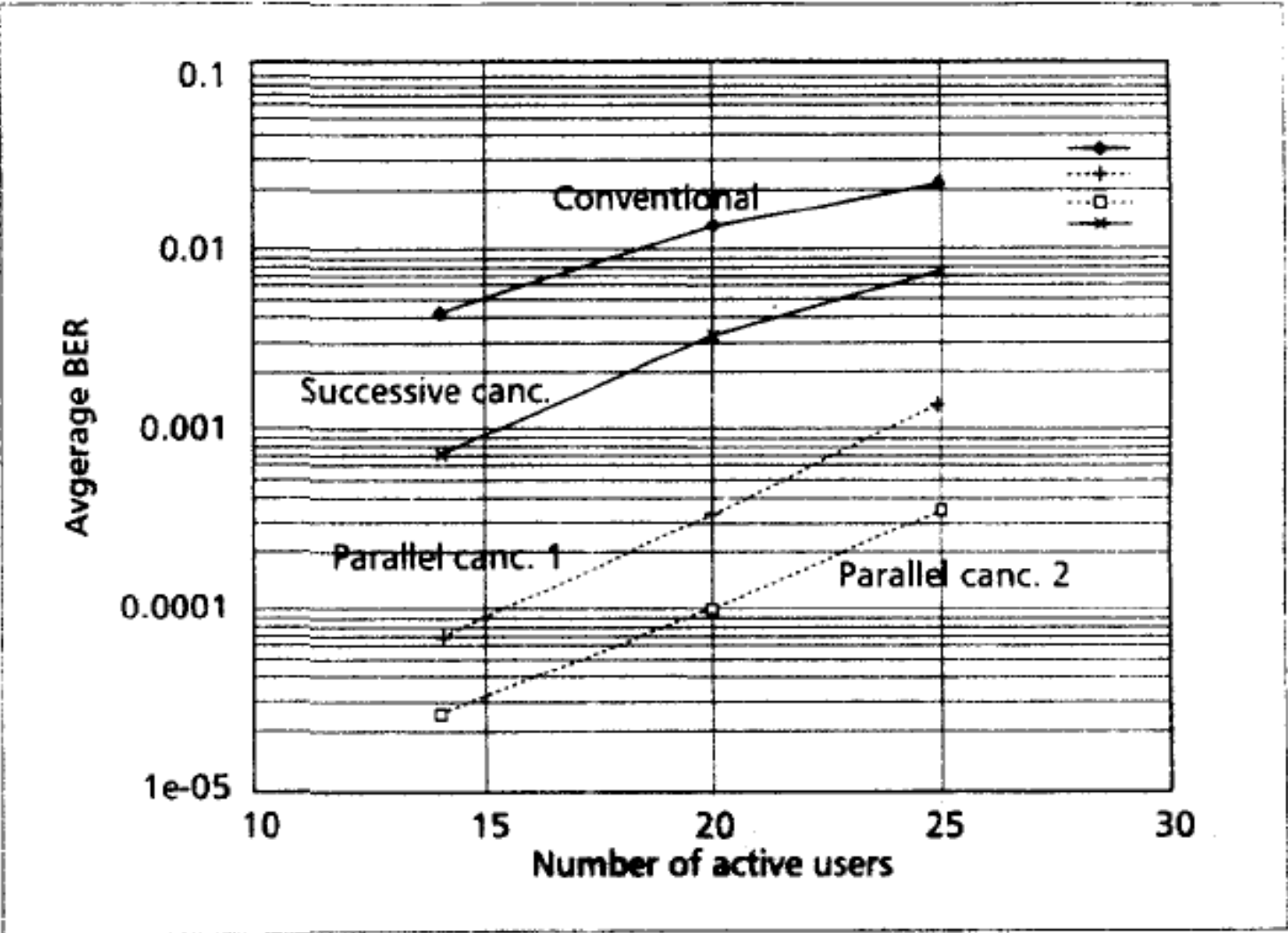

■ Figure 6. BER vs. no. of active users under ideal power control (asynchronous).

Performance of MUD (2)

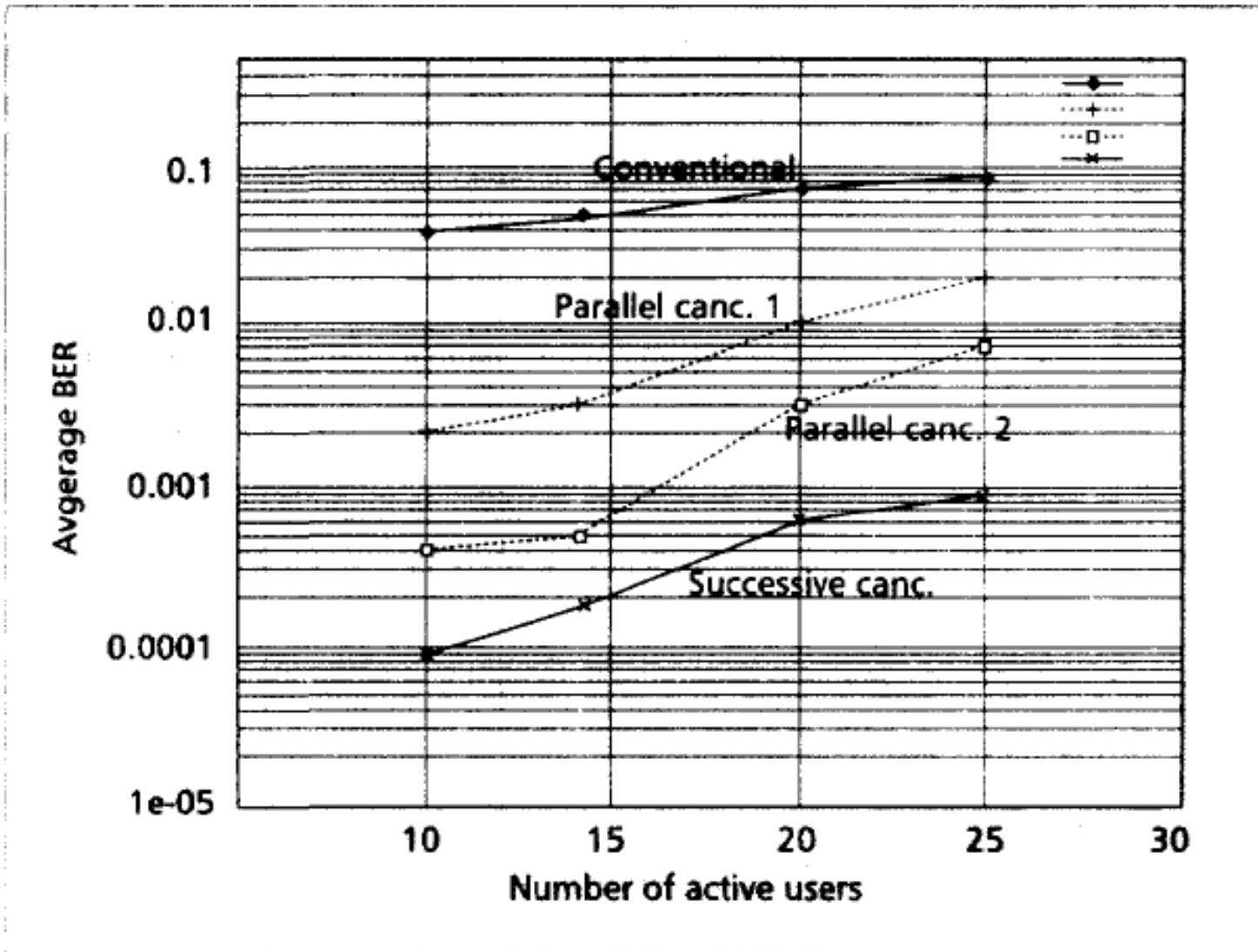

■ Figure 7. BER vs. no. of active users under Rayleigh fading (asynchronous).

Limitations of MUD

- Issues in practical implementation
 - Processing complexity
 - Processing delay
 - Sensitivity and robustness
- Limitations of MUD
 - Potential capacity improvements in cellular systems are not enormous but certainly nontrivial (2.8x upper bound)
 - Capacity improvements only on the uplink would only be partly used anyway in determining overall system capacity
 - Cost of doing MUD must be as low as possible so that there is a performance/cost tradeoff advantage