

CYCLOCONVERTER

Introduction

Cycloconverters directly convert ac signals of one frequency (usually line frequency) to ac signals of variable frequency. These variable frequency ac signals can then be used to directly control the speed of ac motors.

Thyristor-based cycloconverters are typically used in low speed, high power (multi-MW) applications for driving induction and wound field synchronous motors.

Basic Principle of Single phase to Single Phase Cycloconverter

The basic principle of cycloconverter is illustrated by the single phase-to-single phase converter shown below.

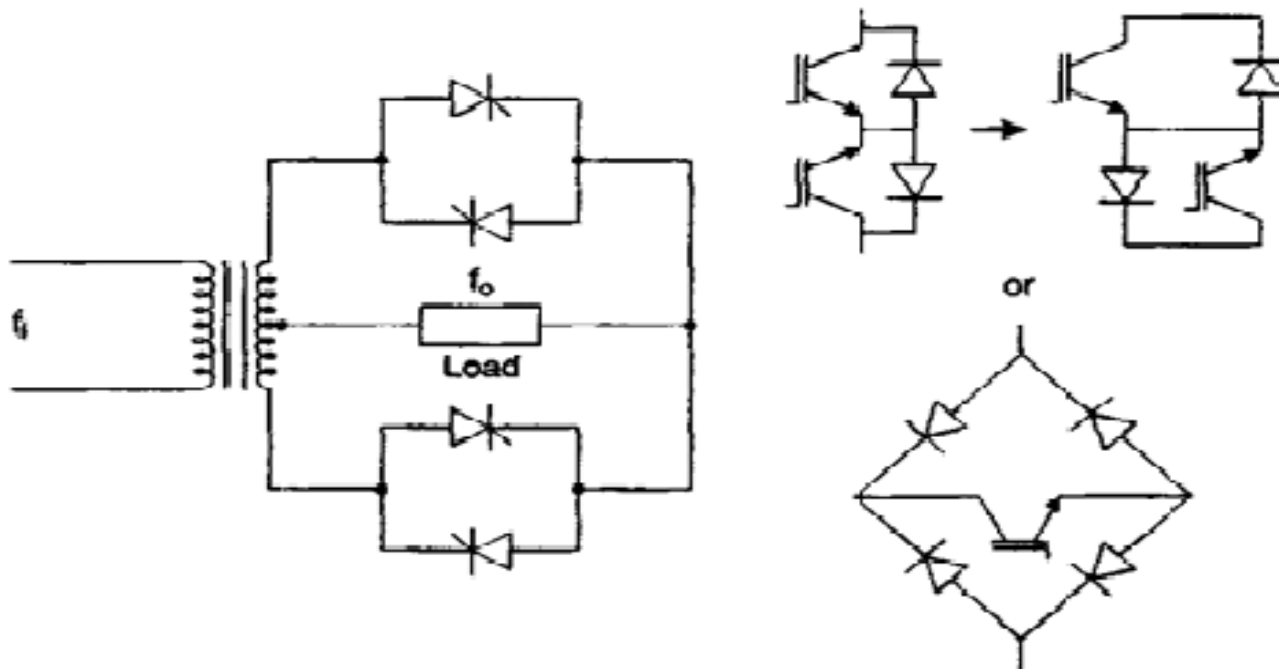

A positive center-tap thyristor converter is connected in anti-parallel with a negative converter of the same type. This allows current/voltage of either polarity to be controlled in the load.

An integral half-cycle output wave is created which has a fundamental frequency $f_0 = (1/n) f_i$ where n is the number of input half-cycles per half-cycle of the output. The thyristor firing angle can be set to control the fundamental component of the output signal.

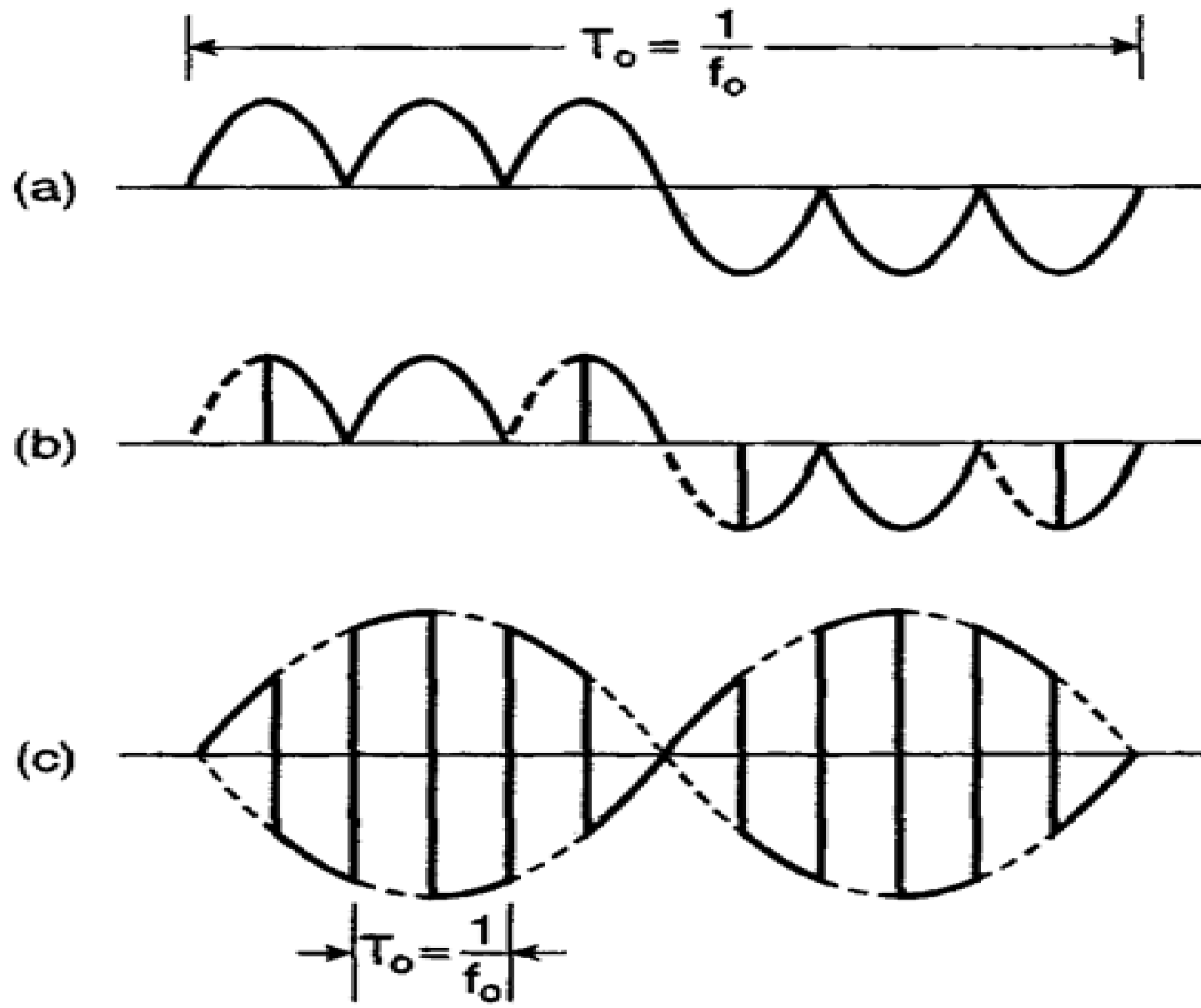

Step-up frequency conversion can be achieved by alternately switching high frequency switching devices (e.g. IGBTs, instead of thyristors) between positive and negative limits at high frequency to generate carrier-frequency modulated output.