

UNIT III

LOAD FLOW ANALYSIS

BUS CLASSIFICATION

1. Slack bus or Reference bus or Swing bus:

$|V|$ and δ are specified. P and Q are unspecified, and to be calculated.

2. Generator bus or PV bus or Voltage controlled bus:

P and $|V|$ are specified. Q and δ are unspecified, and to be calculated

3. Load bus or PQ bus:

P and Q are specified. $|V|$ and δ are unspecified, and to be calculated

PRIMITIVE NETWORK

It is a set of unconnected elements which provides information regarding the characteristics of individual elements. it can be represented both in impedance & admittance form

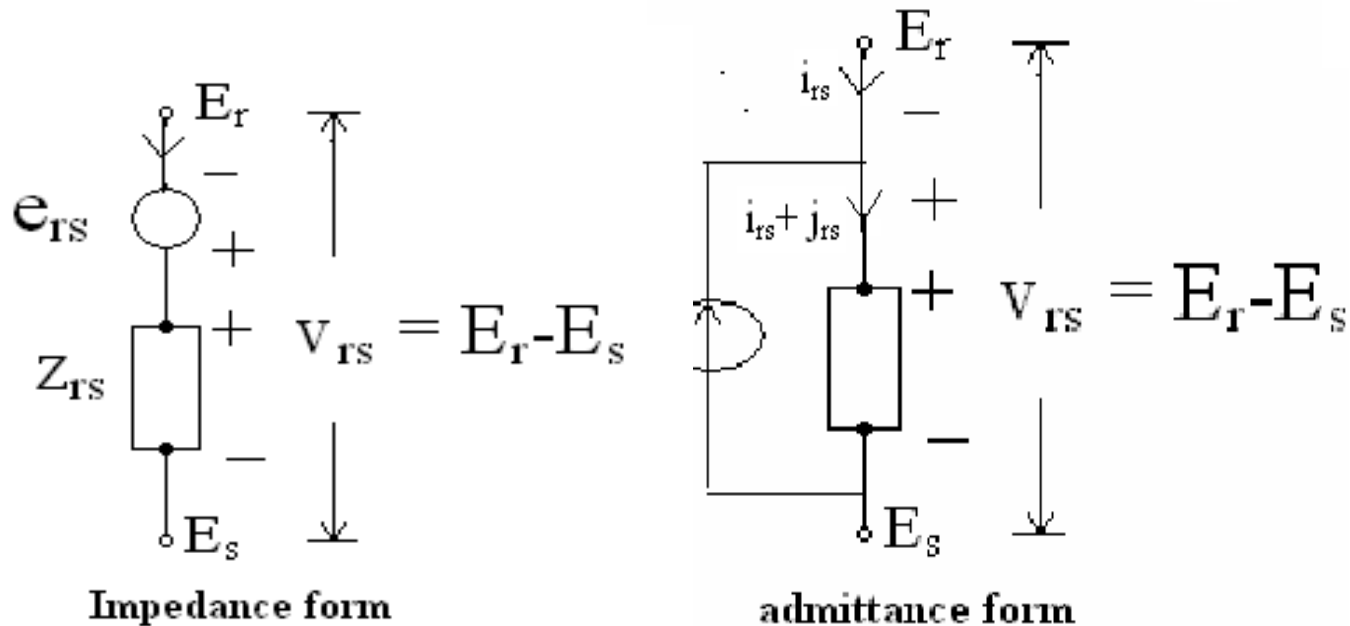

Thank You