

# **Special Electrical Machines**

# SRM Drive System

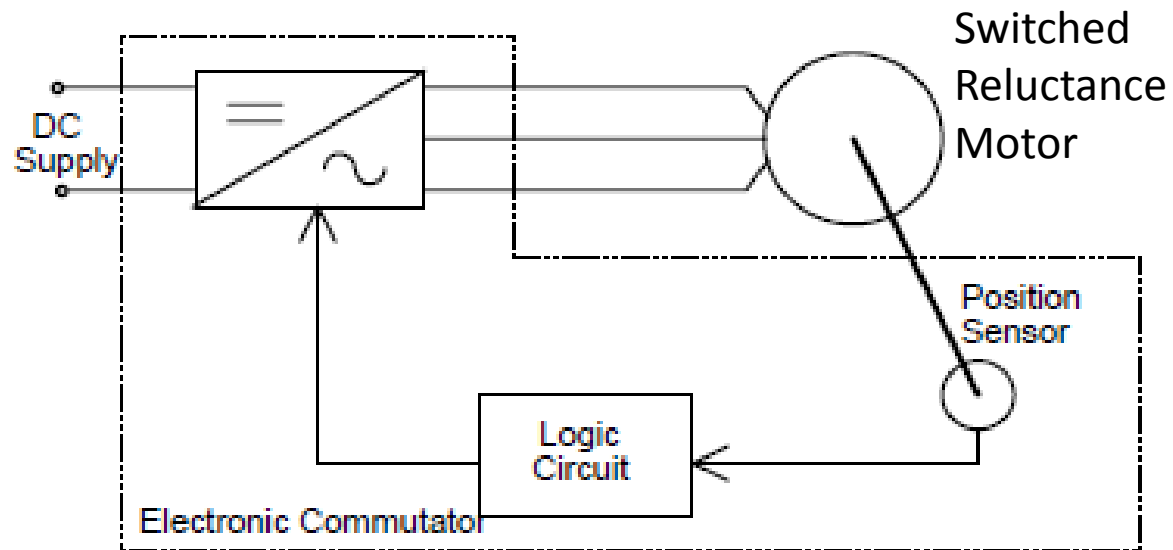

## Position Sensors

Commonly used position sensors are

- Phototransistors and photodiodes
- Hall elements
- Magnetic sensors
- Pulse encoders
- Variable differential transformers

## Power Converters for SRM

Since the torque in SRM drives is independent of the excitation current polarity, the SRM drives require only one power switch per phase winding. for example:

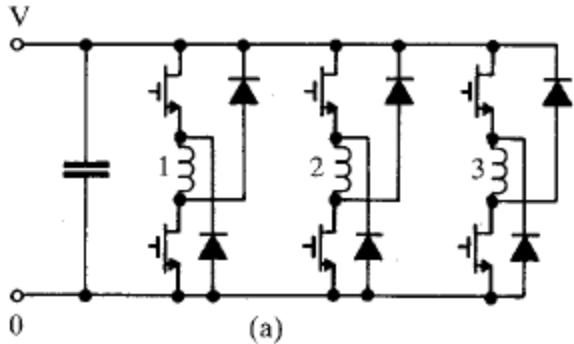

Asymmetric bridge converter

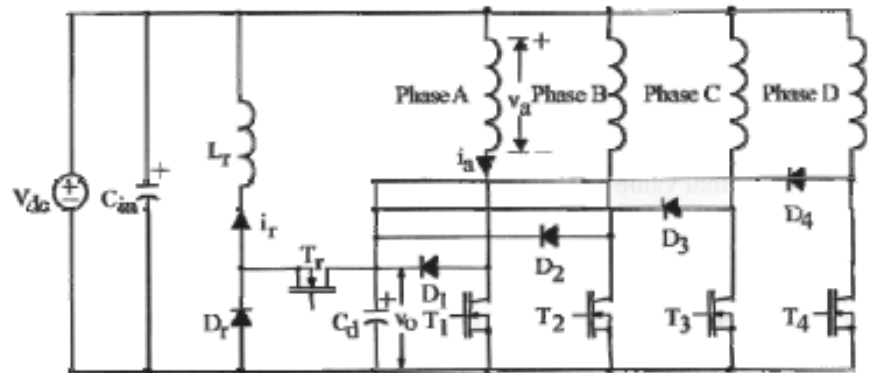

C-dump converter

# Applications



Three 150 kW DIAMOND DRIVES  
underground at Maltby Colliery, UK.

Flameproof drive  
systems for  
potentially explosive  
atmospheres



Maytag's front-loading horizontal-axis  
Neptune washing machine.



Washing  
machine

# Applications-cont.



The German ICE1 high speed train: Deutsche Bahn has selected air cycle air conditioning for its latest ICE3 high speed passenger trains.

Environmentally friendly air conditioning system for passenger trains



Servo systems for advanced technology weaving machine

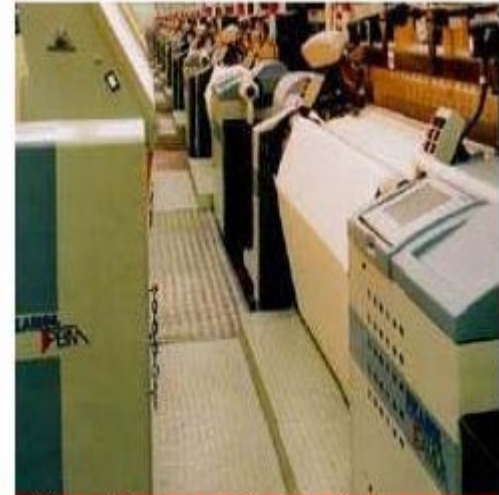

Picanol Gamma rapier: A unique concept with the operator in mind and a head for figures.

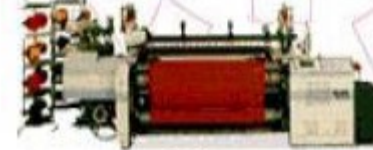

**THANKS....**

Queries Please...