

Data Communications and Networking

UNIT-2

11-7 POINT-TO-POINT PROTOCOL

*Although HDLC is a general protocol that can be used for both point-to-point and multipoint configurations, one of the most common protocols for point-to-point access is the **Point-to-Point Protocol (PPP)**. PPP is a **byte-oriented** protocol.*

Topics discussed in this section:

Framing

Transition Phases

Multiplexing

Multilink PPP

Figure 11.32 *PPP frame format*

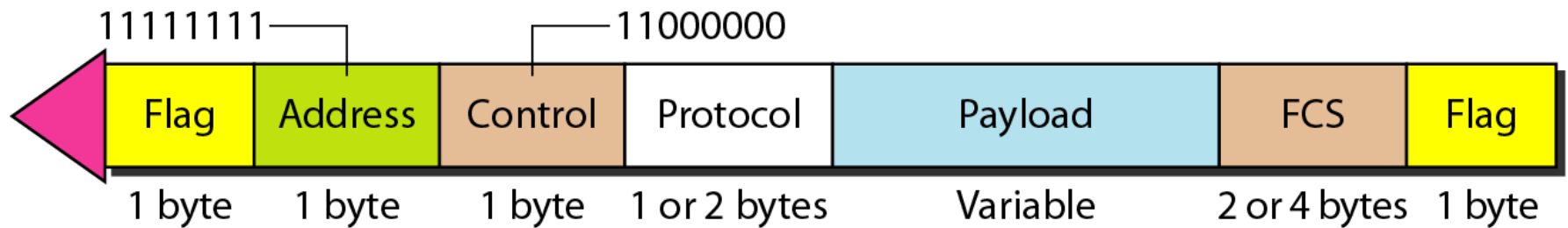



Note

PPP is a byte-oriented protocol using byte stuffing with the escape byte 01111101.

Figure 11.33 *Transition phases*

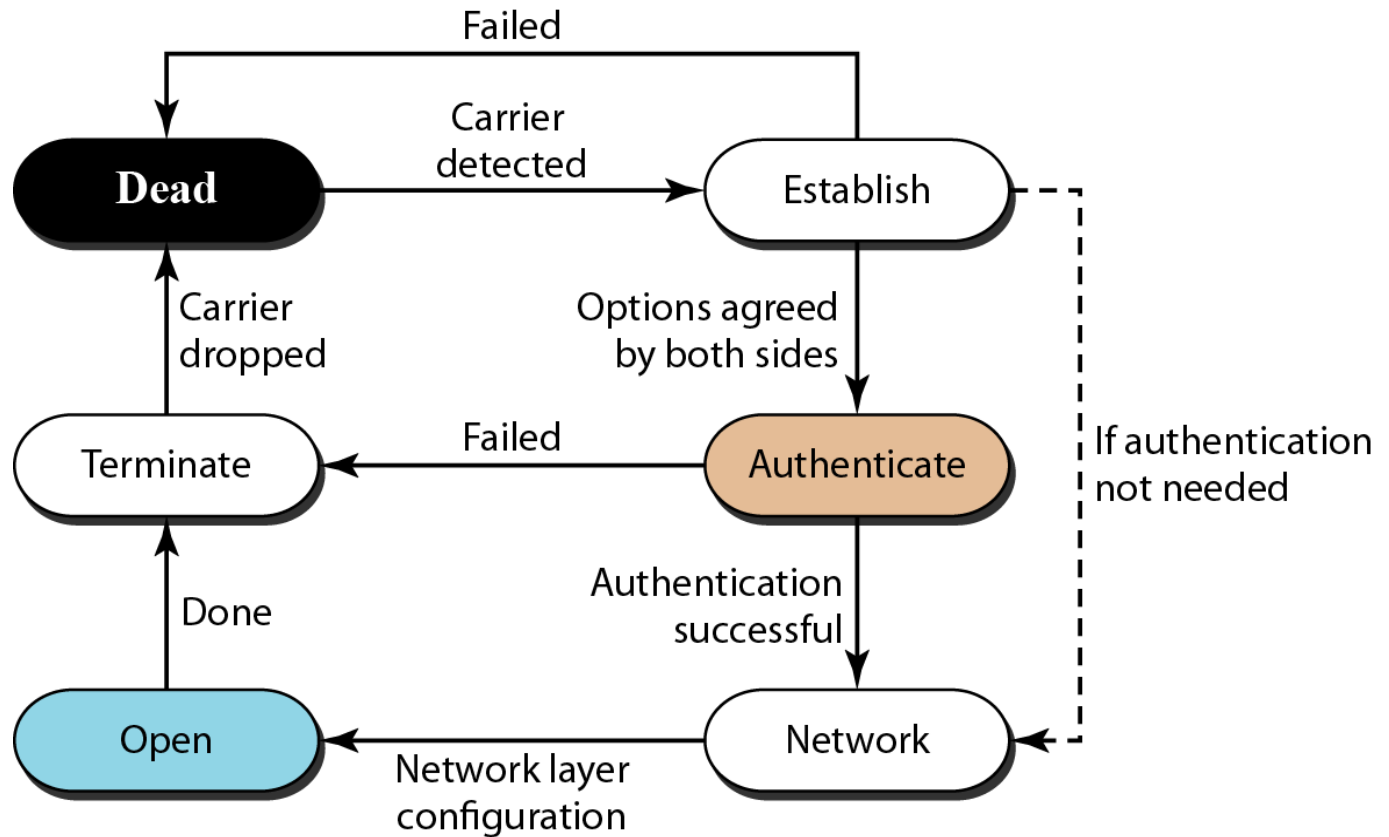
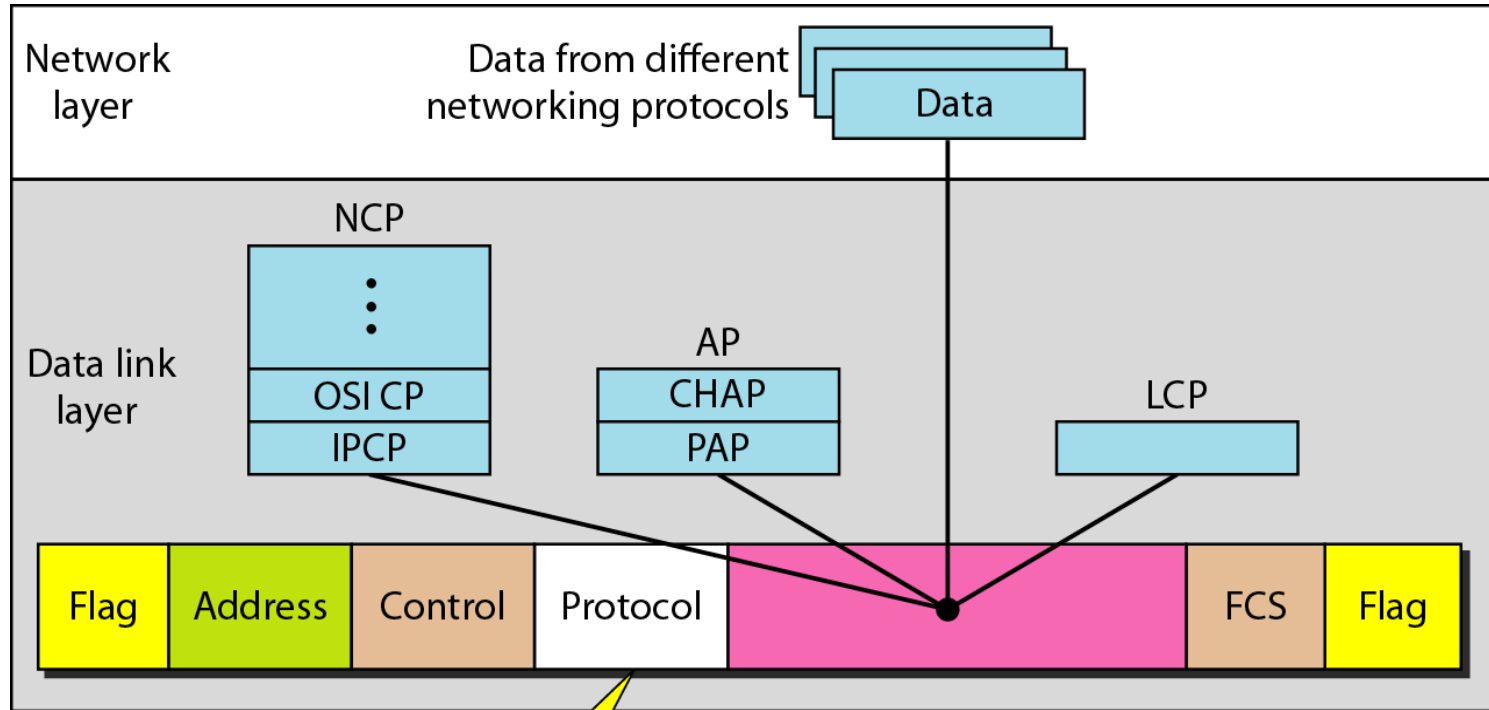

Figure 11.34 *Multiplexing in PPP*



LCP: 0xC021
AP: 0xC023 and 0xC223
NCP: 0x8021 and
Data: 0x0021 and

LCP: Link Control Protocol
AP: Authentication Protocol
NCP: Network Control Protocol

Figure 11.35 *LCP packet encapsulated in a frame*

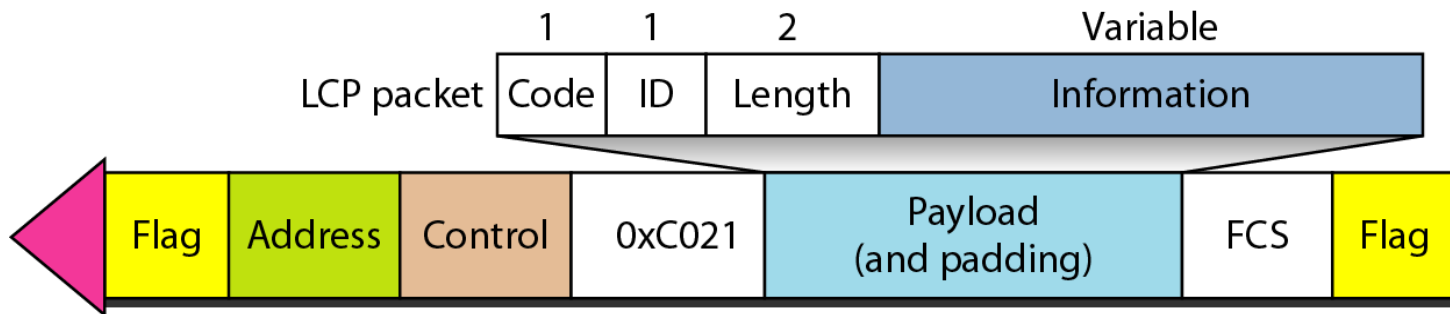

Table 11.2 *LCP packets*

<i>Code</i>	<i>Packet Type</i>	<i>Description</i>
0x01	Configure-request	Contains the list of proposed options and their values
0x02	Configure-ack	Accepts all options proposed
0x03	Configure-nak	Announces that some options are not acceptable
0x04	Configure-reject	Announces that some options are not recognized
0x05	Terminate-request	Request to shut down the line
0x06	Terminate-ack	Accept the shutdown request
0x07	Code-reject	Announces an unknown code
0x08	Protocol-reject	Announces an unknown protocol
0x09	Echo-request	A type of hello message to check if the other end is alive
0x0A	Echo-reply	The response to the echo-request message
0x0B	Discard-request	A request to discard the packet

Table 11.3 *Common options*

<i>Option</i>	<i>Default</i>
Maximum receive unit (payload field size)	1500
Authentication protocol	None
Protocol field compression	Off
Address and control field compression	Off

Figure 11.36 *PAP packets encapsulated in a PPP frame*

