

Internal Combustion Engines

Supercharging & Turbocharging

Ba c k g r o u n d

□ The power output of an engine depends upon the amount of air inducted per unit time and the degree of utilization of this air, and the thermal efficiency of the engine.

□ Three possible methods utilized to increase the air consumption of an engine are as follows:

Background

- **Increasing the piston displacement:** This increases the size and weight of the engine, and introduces additional cooling problems.
- **Running the engine at higher speeds:** This results in increased mechanical friction losses and imposes greater inertia stresses on engine parts.
- **Increasing the density of the charge:** This allows a greater mass of the charge to be inducted into the same volume.

De finitio n

□ The method of increasing the air capacity of an engine is known as **supercharging**. The device used to increase the air density is known as **supercharger**.

□ **Supercharger** is merely a blower or a compressor that provides a denser charge to the engine.

Objectives

- For ground installations, it is used to produce a gain in the power output of the engine.
- For aircraft installations, in addition to produce a gain in the power output at sea-level, it also enables the engine to maintain a higher power output as altitude is increased.

SI Engines

□ Supercharging in SI engine is employed only in aircraft and racing car engines. Apart from increasing the volumetric efficiency of the engine, supercharging results in an increase in the **intake temperature** of the engine.

□ This reduces the ignition delay and increases the flame speed. Both these effects result in a greater tendency to **knock or pre-ignite**. For this reason, the supercharged petrol engines employ lower compression ratios.

CI Engines

□ In case of CI engines, supercharging does not result in any combustion problem, rather it **improves** combustion.

□ Increase of pressure and temperature of the inducted air reduces **ignition delay**, and hence the rate of pressure rise results in a better, **quieter and smoother** combustion.

Supercharging Methods

1. Mechanical Supercharger: In this case, blower is driven by the engine crankshaft. The blower is usually a positive displacement type that runs at the engine speed. This allows quick response to the throttle change.

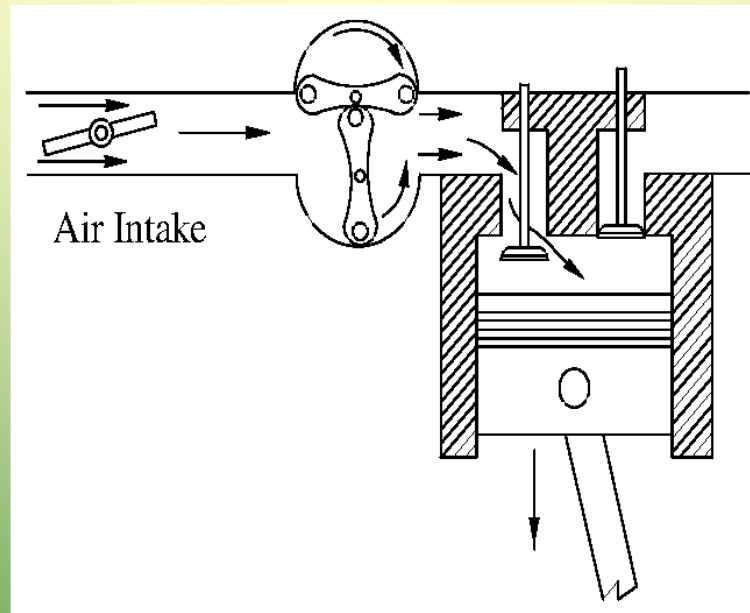

Supercharging Methods

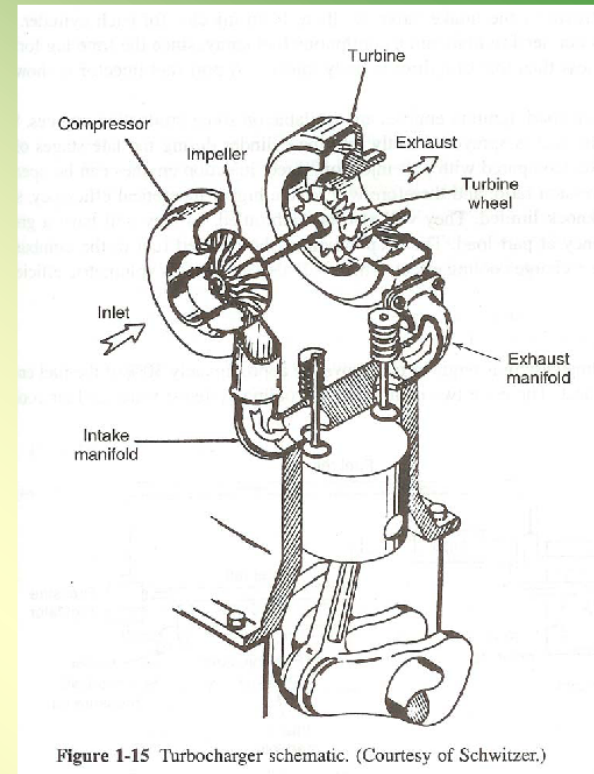
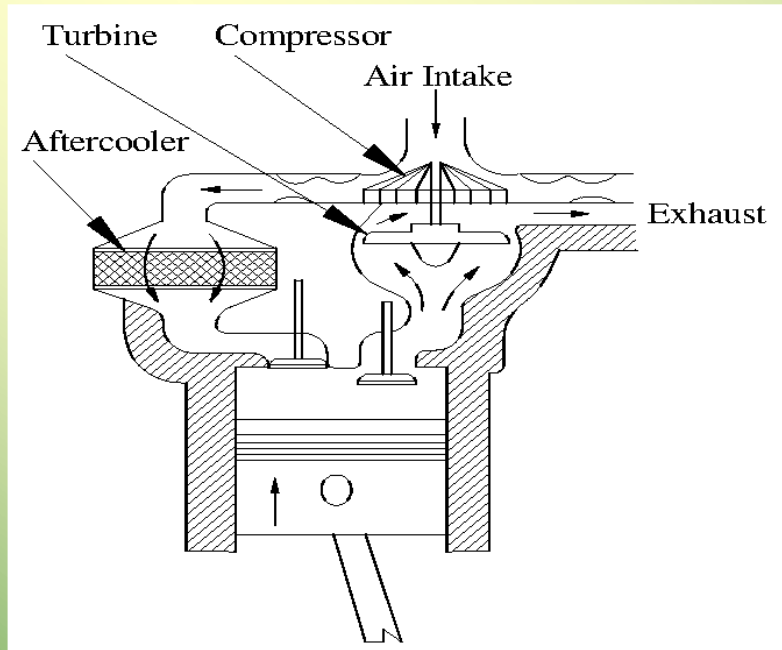
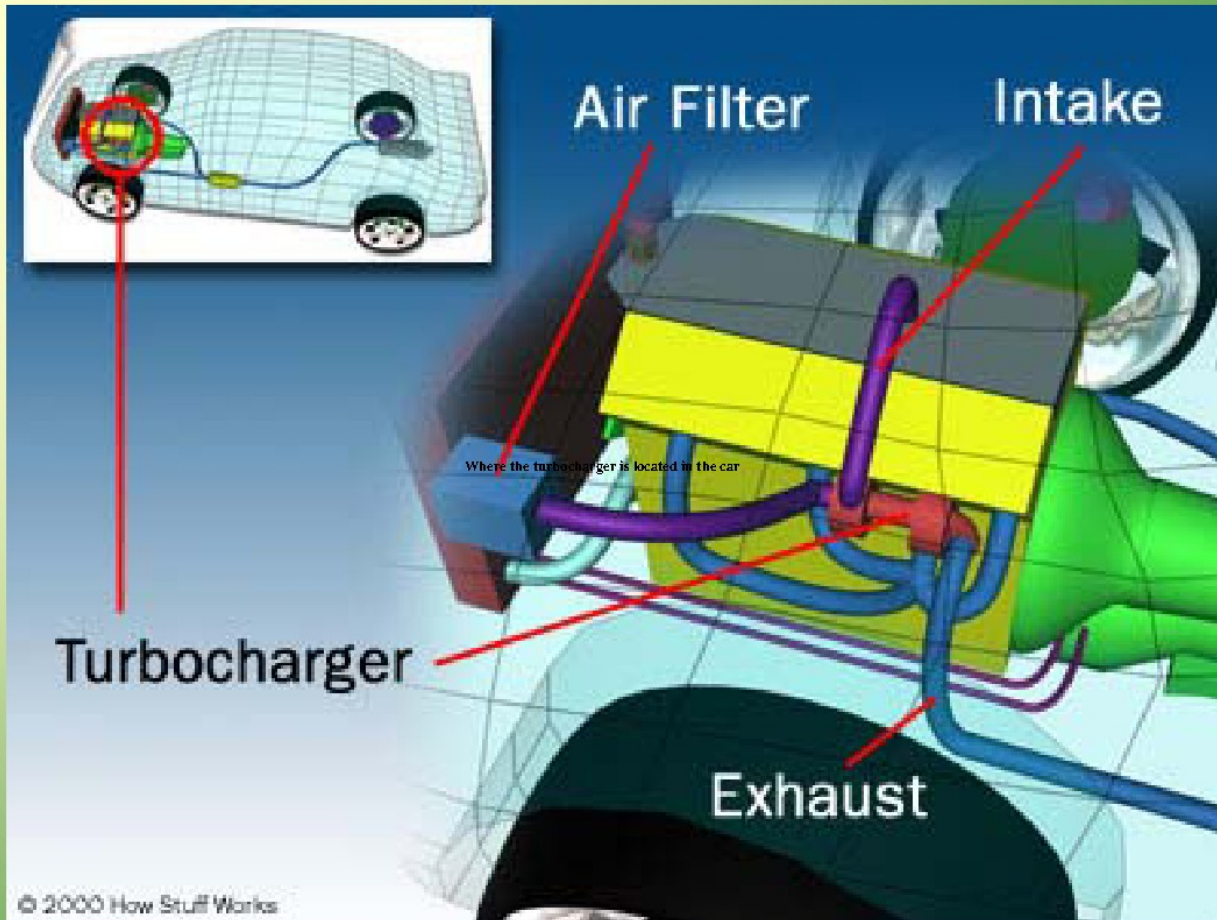
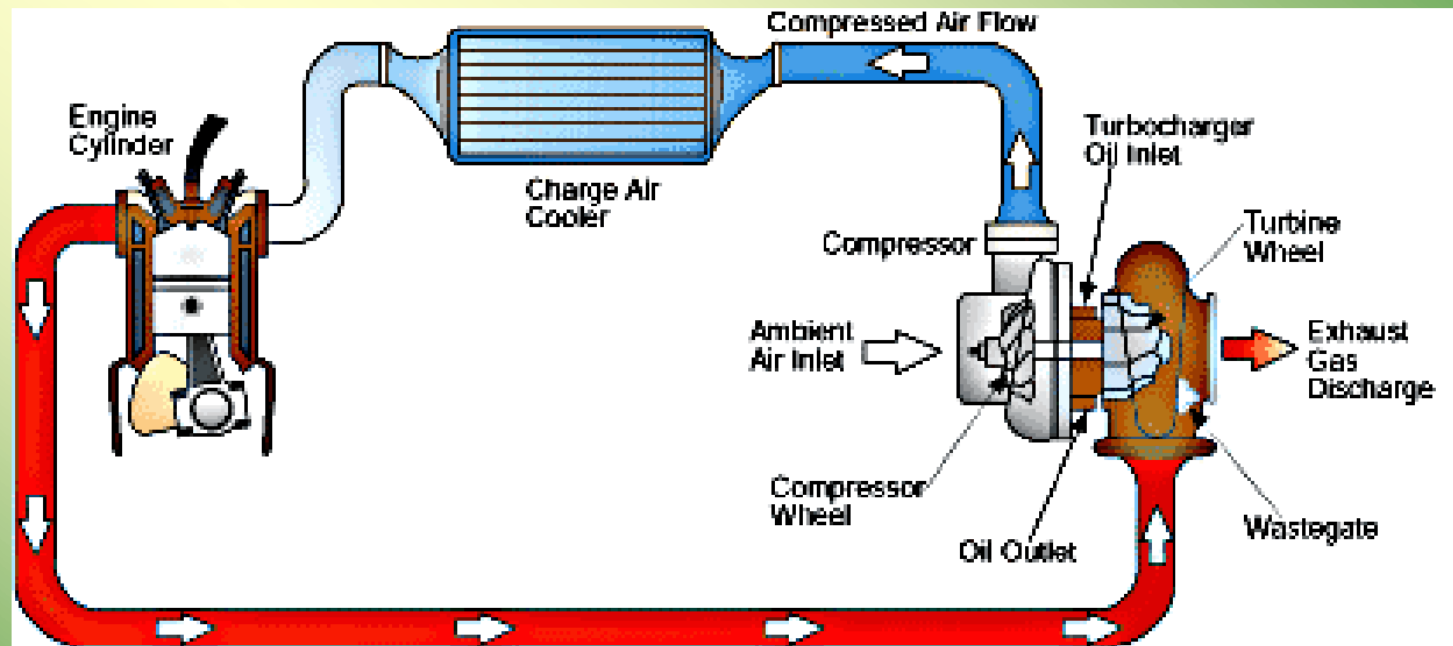

Figure 1-15 Turbocharger schematic. (Courtesy of Schwitzer.)

2. Turbocharger: The blower/compressor and the turbine are mounted on the same shaft. The compressor is run by the turbine, and the turbine, in turn, is run by the exhaust gases.



Where the turbocharger is located in the car



How a turbocharger is plumbed (including the charge air cooler)

Types of Compressors

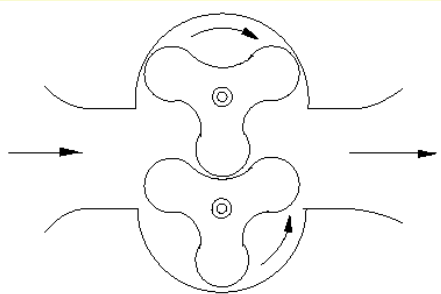

Roots Blower

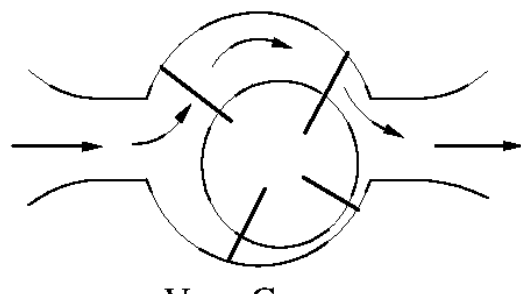

Vane Compressor

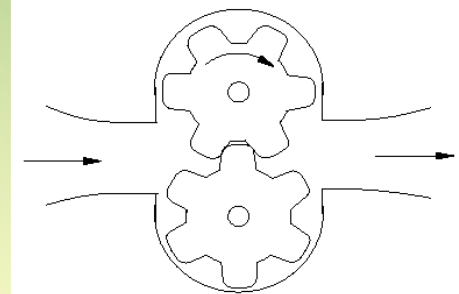

Screw Compressor

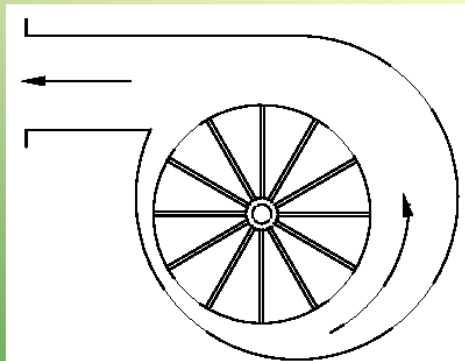

Radial compressor

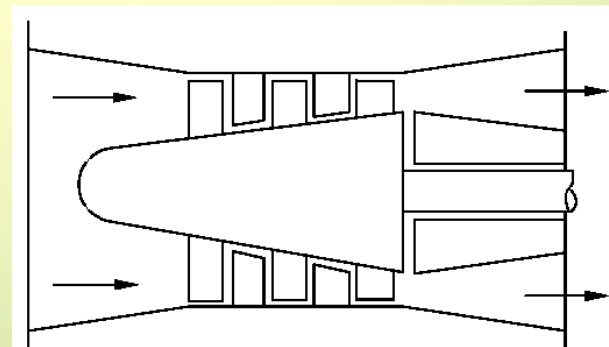

Axial compressor

Compressors

□ In **roots blower**, air is compressed by a meshing gear arrangement, whereas in case of **vane blower**, air is compressed by a rotating vane element. In both these types, a volume of air is taken from the intake and discharged at the outlet end. The air is compressed as it is forced against the higher pressures at the outlet side of the compressor.

□ The **screw type traps the air between the intermeshing helical shaped gear and forces the flow towards the outlet end axially.**

□ These **positive displacement superchargers are used in stationary plants, vehicles and marine installations.**

Compressors

□ The centrifugal type is exclusively used as the supercharger with reciprocating power plants for aircraft, because it is relatively light and compact, and produces a continuous flow.

□ The axial type is mainly employed in gas turbines, and is seldom used in supercharging reciprocating engines.

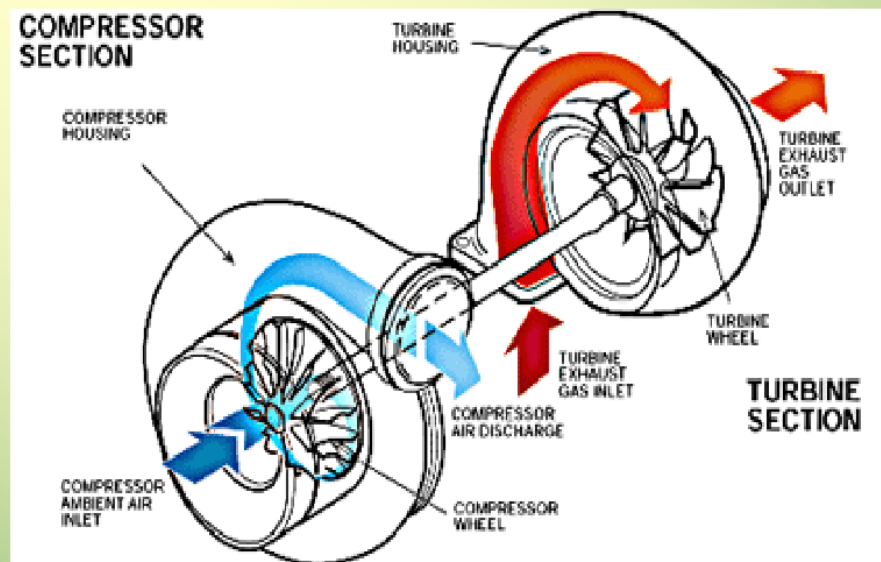

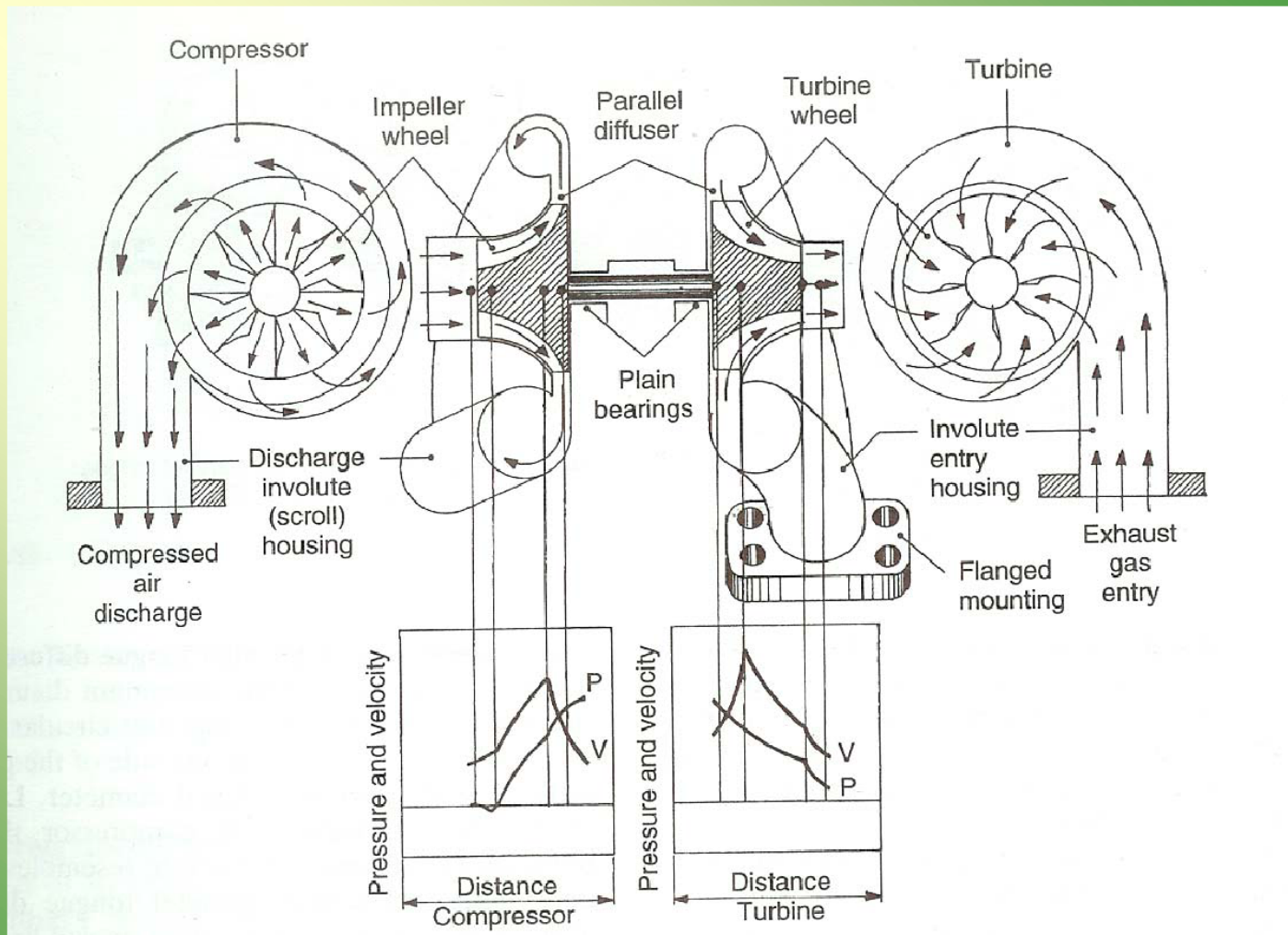

Turbo charger principle

Flow Processes in a Compressor

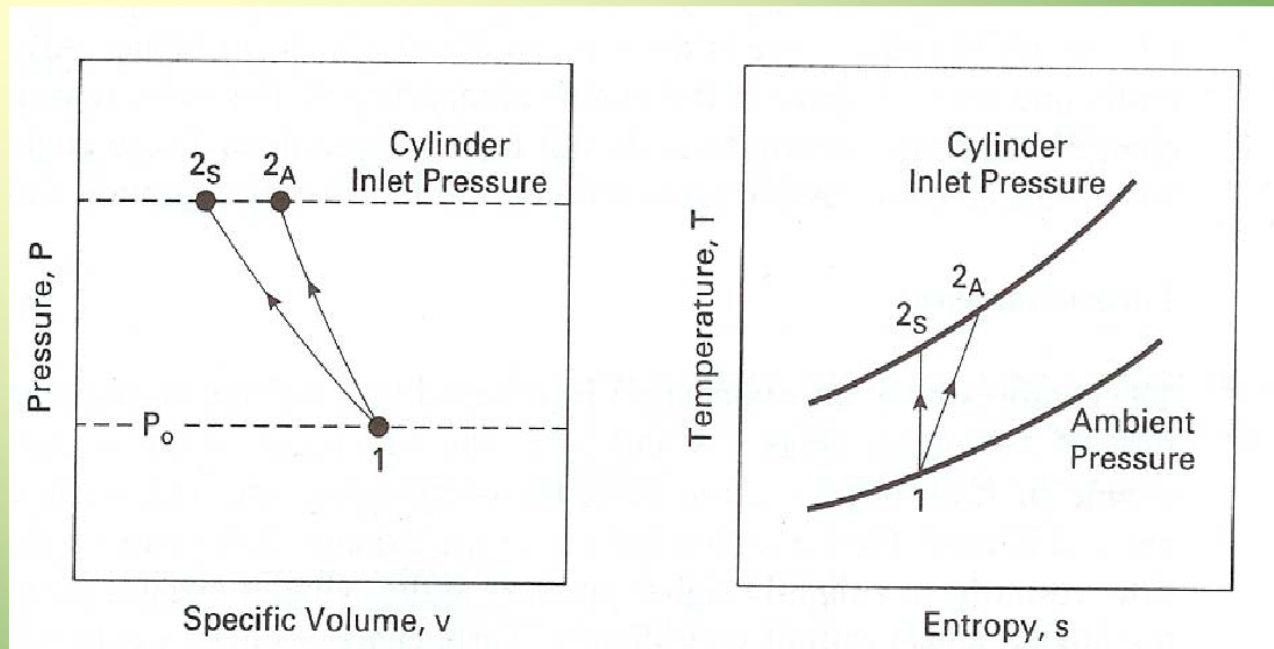

Ideal flow process (1-2_s) and actual flow process (1-2_A) through a supercharger or a turbocharger compressor in (a) pressure-volume coordinates, and (b) temperature entropy coordinates.

Flow Processes in a turbine

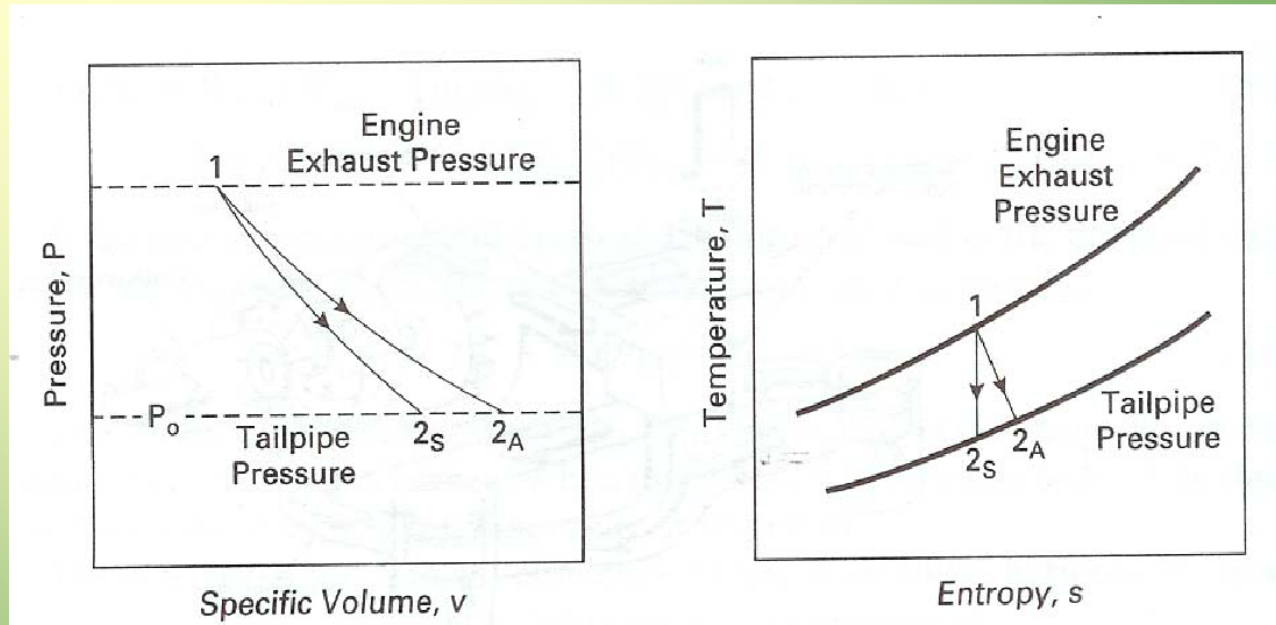

Ideal flow process (1-2_s) and actual flow process (1-2_A) through the turbine of a turbocharger in (a) pressure-volume coordinates, and (b) temperature entropy coordinates.

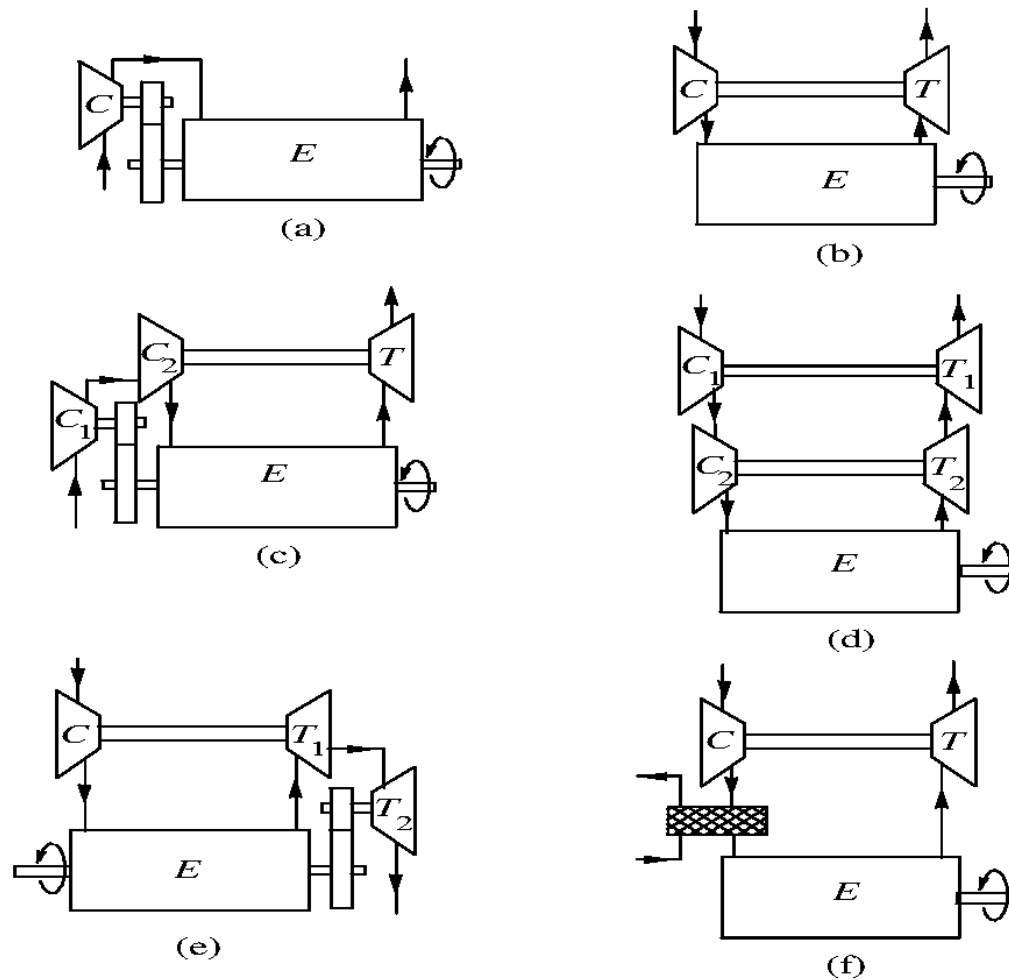

(a) Mechanical supercharger, (b) turbocharging, (c) engine driven compressor and turbocharger, (d) two-stage turbocharging, (e) turbocharging with turbocompounding (f) turbocharger with intercooler

Turbo lag

❖ One of the main problems with turbochargers is that they do not provide an immediate power boost when you step on the gas. It takes a second for the turbine to get up to speed before boost is produced. This results in a feeling of lag when you step on the gas, and then the car lunges ahead when the turbo gets moving.

❖ One way to decrease turbo lag is to reduce the inertia of the rotating parts, mainly by reducing their weight. This allows the turbine and compressor to accelerate quickly, and start providing boost earlier.

Use of After-coolers/ Inter-coolers

□ In the process of raising the input air pressure, supercharger also raises the inlet air temperature by compressive heating. This is undesirable in SI engines. If the temperature at the start of the compression stroke is higher, all temperatures in the rest of the cycle will also be higher. This causes self-ignition.

□ To avoid this, many superchargers are equipped with an aftercooler that cools the compressed air to a lower temperature. The aftercooler can be either an air-to-air heat exchanger or an air-to-liquid heat exchanger.

After coolers/ Intercoolers

□ The temperature drop through an after cooler is usually expressed in terms of effectiveness, defined as the ratio of the measured temperature drop to the maximum possible temperature drop that would bring the cooled fluid to the coolant temperature.

$$C_c = \frac{T_1 - T_2}{T_1 - T_w}$$

where, T_1 = entrance stagnation temperature

T_2 = exit stagnation temperature

T_w = coolant entrance temperature

C_c = cooler effectiveness

A f t e r c o o l e r s / I n t e r c o o l e r s

- Obviously, an effectiveness of unity would require an infinitely large cooler. An effectiveness of 0.6 to 0.8 usually keeps cooler size within reasonable limits.**
- The use of cooler inevitable involves a pressure loss. A well designed cooler will involve a loss of 2-3 % of the entering absolute pressure.**
- Air-cooled aftercoolers are used in aircraft , while water-cooled aftercoolers are attractive for marine and stationary installations where there is an abundance of water.**

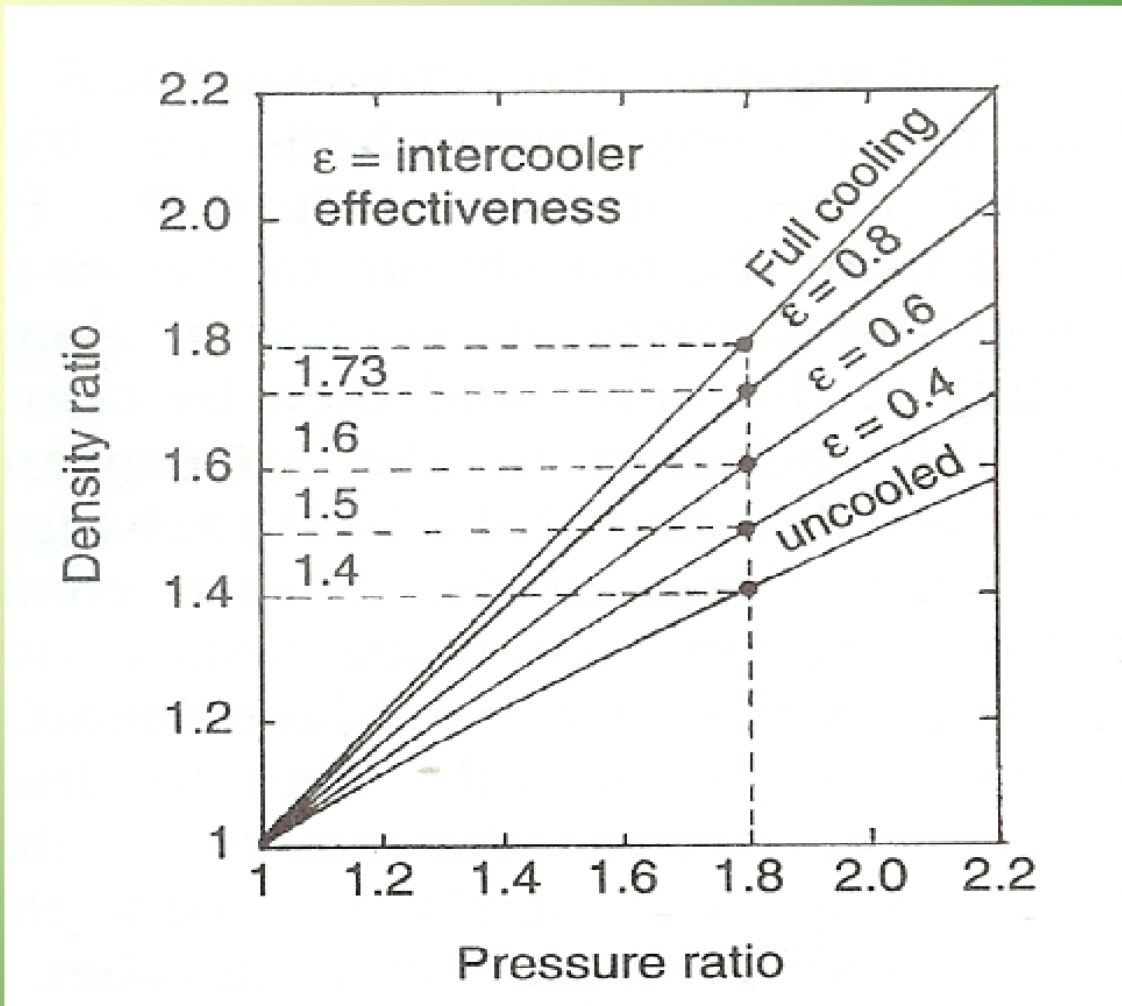

Effects of aftercooler effectiveness on air density with different pressure ratios

Use of After-coolers

- ❑ The aftercoolers are not needed on superchargers used in **CI engines**, because there is no concerns about engine knock.
- ❑ Aftercoolers are costly and takes up space in the engine compartment. For these reasons, superchargers on some automobiles do not have aftercoolers. These engines usually have **reduced compression ratios** to avoid problems of self-ignition.

Two-stage Supercharger

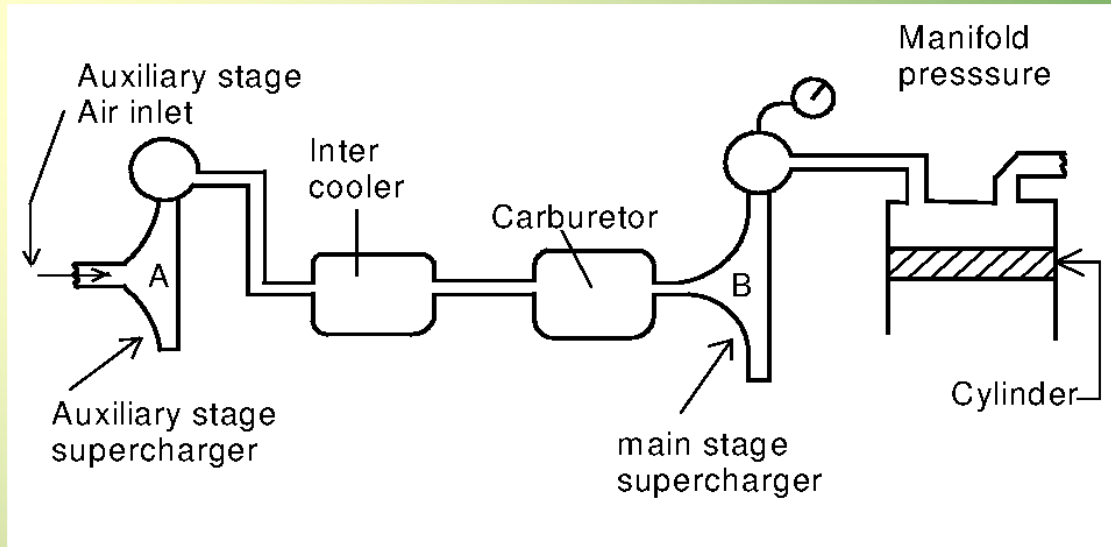

□ A single stage supercharger becomes prohibitive in size and weight for high altitude planes. Two stage superchargers are, therefore, used for high altitude aircraft. Two superchargers are used in tandem, and the charge is compressed in two stages. Such an arrangement produces the necessary compression without the excessive size or speed of the impeller that would be required for a single stage supercharger of same capacity.

Two-stage Supercharger- contd.

□ It also provides a convenient arrangement for the use of an intercooler between the stages to assist in keeping the temperature of the charge from exceeding the detonation limits due to compression. One typical arrangement of a two-stage supercharger is shown. **At low altitudes, only the main stage (B) is used and the air enters through the main stage air inlet. At some altitude, where the main stage no longer has sufficient capacity to provide the mass of air required, the auxiliary stage is cut in, main stage air inlet is closed, and the air is inducted through the auxiliary air inlet.**

Two-stage Supercharger-contd.

□ The auxiliary supercharger then compresses the air, which passes through the intercooler where its temperature is reduced, and then flows into main stage compressor where it is compressed further. The auxiliary stage sometimes may be two-speed, and the installation is known as a two-stage, two-speed supercharger.

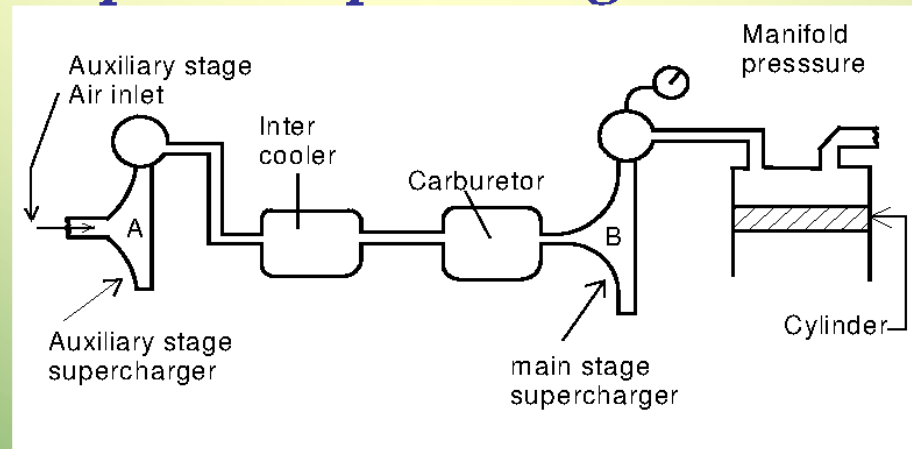

Turbo-supercharger

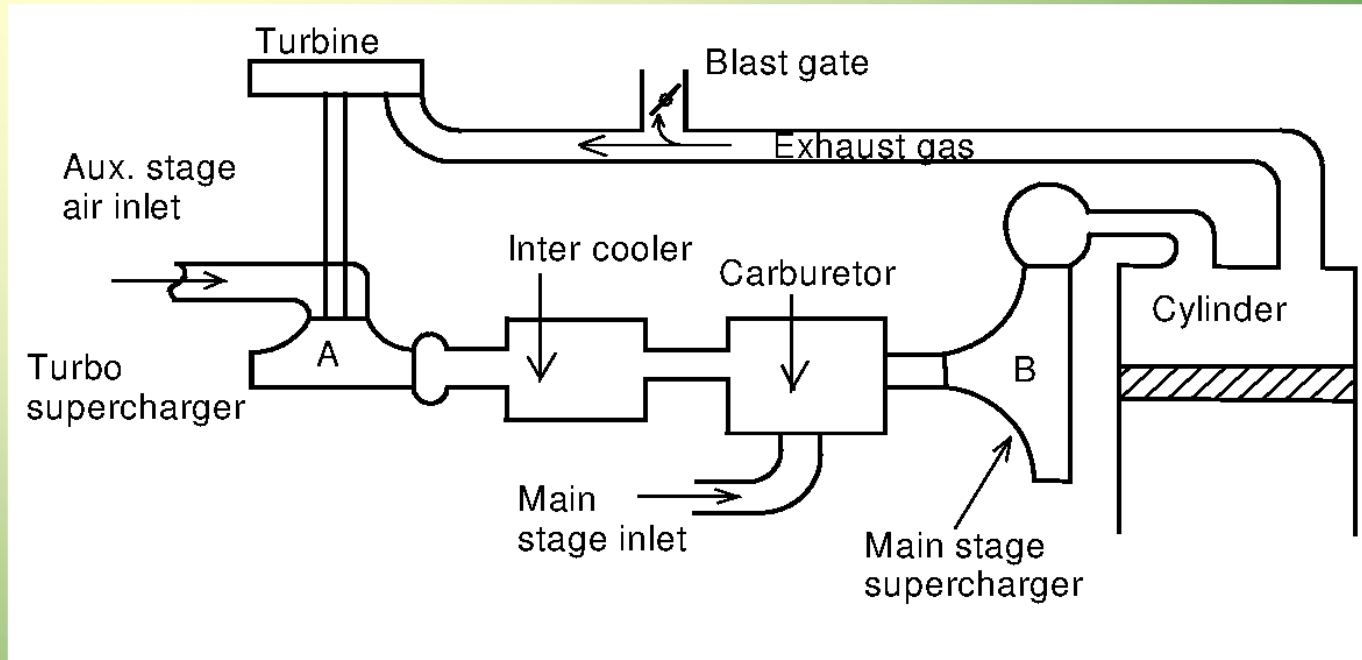

□ A turbocharger or turbo-supercharger is often used for high altitude aircraft. Figure above represents a two-stage system in which the auxiliary stage is driven by energy remaining in the exhaust gas.

Turbo - super charger - contd.

□ At low altitudes, the auxiliary stage is not used and the exhaust gases are passed to the atmosphere through an open blast gate. When it becomes necessary to use the auxiliary stage (A) at higher altitude, the blast gate is closed forcing the exhaust gases to pass through a turbine wheel, which in turn drives the auxiliary stage. This stage is thus a variable speed supercharger whose capacity is increased by increasing the flow of the exhaust gases through the turbine by reducing the blast gate opening. When the blast gate is fully closed, the maximum capacity of the supercharger can be obtained.

Summary

- **Altitude performance is improved by Supercharging.**
 - Compresses the air entering the manifold by means of a compressor.
- **Gear Driven Supercharger – driven by a gear train from the engine crank shaft.**
 - Critical Altitude – power increases till this is reached. Then decreases.
- **Exhaust Turbocharger – powered by engine exhaust.**
 - No loss of power since power is not extracted from the engine.
 - Can maintain sea level rated power for much higher altitudes.

References

1. **Crouse WH, and Anglin DL**, (1985), *Automotive Engines*, Tata McGraw Hill.
2. **Eastop TD, and McConkey A**, (1993), *Applied Thermodynamics for Engg. Technologists*, Addison Wisley.
3. **Ferguson CR, and Kirkpatrick AT**, (2001), *Internal Combustion Engines*, John Wiley & Sons.
4. **Ganesan V**, (2003), *Internal Combustion Engines*, Tata McGraw Hill.
5. **Gill PW, Smith JH, and Ziurys EJ**, (1959), *Fundamentals of I. C. Engines*, Oxford and IBH Pub Ltd.
6. **Heisler H**, (1999), *Vehicle and Engine Technology*, Arnold Publishers.
7. **Heywood JB**, (1989), *Internal Combustion Engine Fundamentals*, McGraw Hill.
8. **Heywood JB, and Sher E**, (1999), *The Two-Stroke Cycle Engine*, Taylor & Francis.
9. **Joel R**, (1996), *Basic Engineering Thermodynamics*, Addison-Wesley.
10. **Mathur ML, and Sharma RP**, (1994), *A Course in Internal Combustion Engines*, Dhanpat Rai & Sons, New Delhi.
11. **Pulkrabek WW**, (1997), *Engineering Fundamentals of the I. C. Engine*, Prentice Hall.
12. **Rogers GFC, and Mayhew YR**, (1992), *Engineering Thermodynamics*, Addison Wisley.
13. **Srinivasan S**, (2001), *Automotive Engines*, Tata McGraw Hill.
14. **Stone R**, (1992), *Internal Combustion Engines*, The Macmillan Press Limited, London.
15. **Taylor CF**, (1985), *The Internal-Combustion Engine in Theory and Practice*, Vol.1 & 2, The MIT Press, Cambridge, Massachusetts.

Web Resources

1. <http://www.mne.psu.edu/simpson/courses>
2. <http://me.queensu.ca/courses>
3. <http://www.eng.fsu.edu>
4. <http://www.personal.utulsa.edu>
5. <http://www.glenroseffa.org/>
6. <http://www.howstuffworks.com>
7. <http://www.me.psu.edu>
8. <http://www.uic.edu/classes/me/me429/lecture-air-cyc-web%5B1%5D.ppt>
9. <http://www.osti.gov/fcv/HETE2004/Stable.pdf>
10. <http://www.rmi.org/sitepages/pid457.php>
11. <http://www.tpub.com/content/engine/14081/css>
12. <http://webpages.csus.edu>
13. http://www.nebo.edu/misc/learning_resources/ppt/6-12
14. http://netlogo.modelingcomplexity.org/Small_engines.ppt
15. <http://www.ku.edu/~kunrotc/academics/180/Lesson%2008%20Diesel.ppt>
16. <http://navsci.berkeley.edu/NS10/PPT/>
17. <http://www.career-center.org/secondary/powerpoint/sge-parts.ppt>
18. <http://mcdetflw.tecom.usmc.mil>
19. <http://ferl.becta.org.uk/display.cfm>
20. http://www.eng.fsu.edu/ME_senior_design/2002/folder14/ccd/Combustion
21. <http://www.me.udel.edu>
22. <http://online.physics.uiuc.edu/courses/phys140>
23. <http://widget.ecn.purdue.edu/~yanchen/ME200/ME200-8.ppt>