

Source Transformations

The Node-Voltage Method and the Mesh-Current Method are powerful techniques for solving circuits.

We are still interested in methods that can be used to simplify circuits like to what we did in parallel and series resistors and Δ to Y transformations

A method called **Source Transformations** will allow the transformations of a voltage source in series with a resistor to a current source in parallel with resistor.

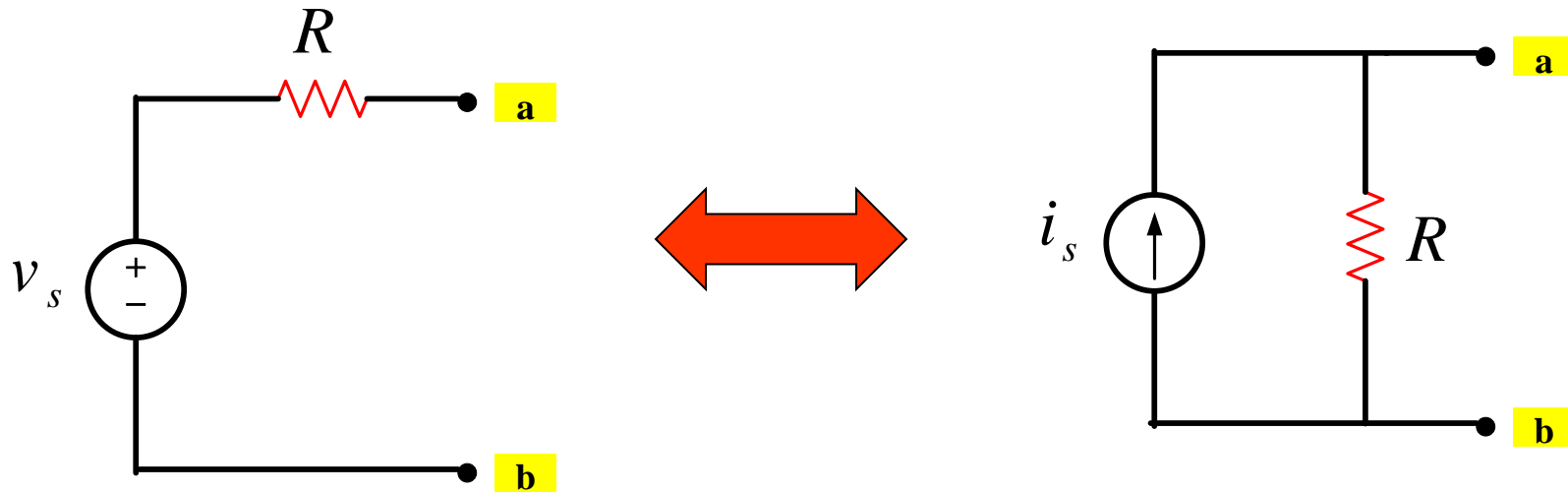

The double arrow indicates that the transformation is bilateral, that we can start with either configuration and derive the other

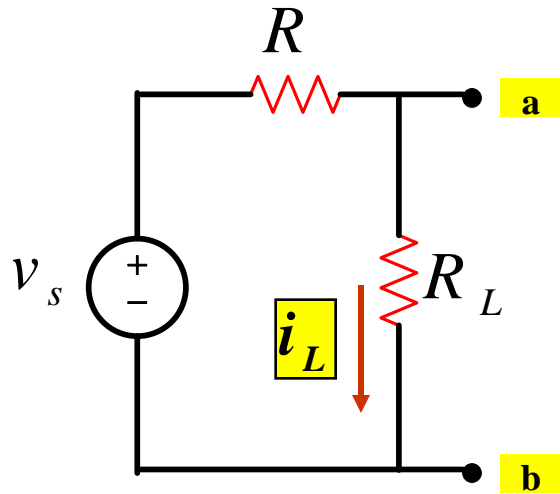

$$i_L = \frac{v_s}{R + R_L}$$

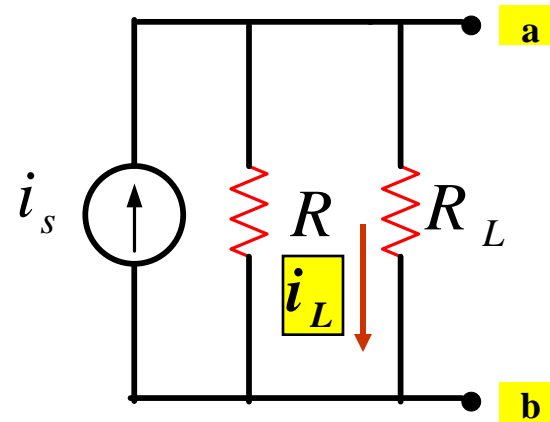

$$i_L = \frac{R}{R + R_L} i_s$$

Equating we have ,

$$\frac{v_s}{R + R_L} = \frac{R}{R + R_L} i_s \quad \Rightarrow \quad i_s = \frac{v_s}{R} \quad \text{OR} \quad v_s = R i_s$$

Example State whether the 6 V source is absorbing or delivering power

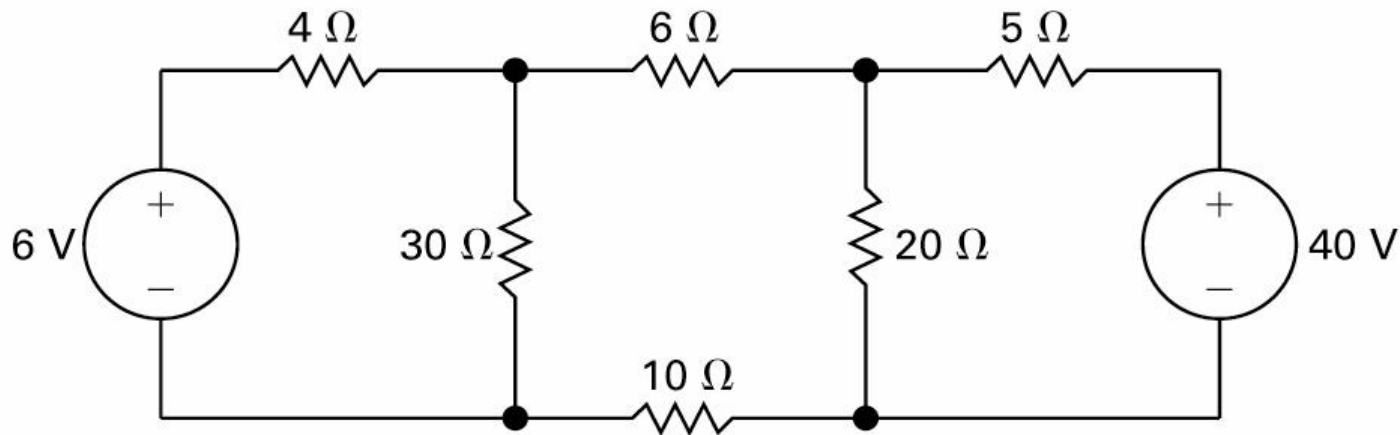

We are going to use source transformation to reduce the circuit, however note that we will not alter or transfer the **6 V** source because it is the objective.

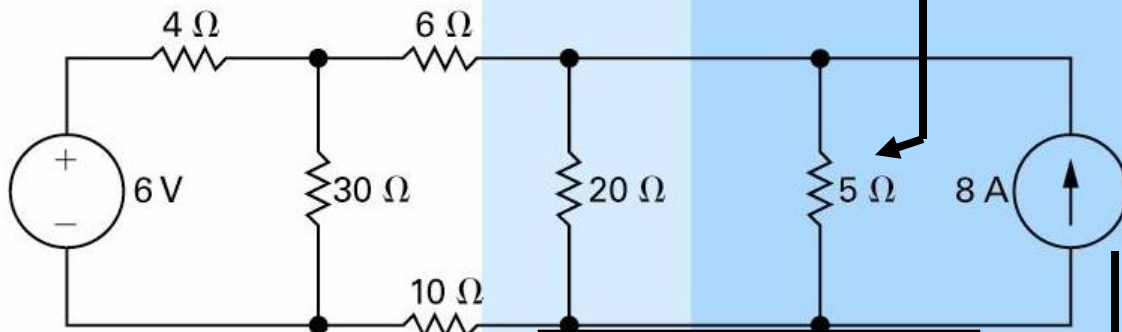
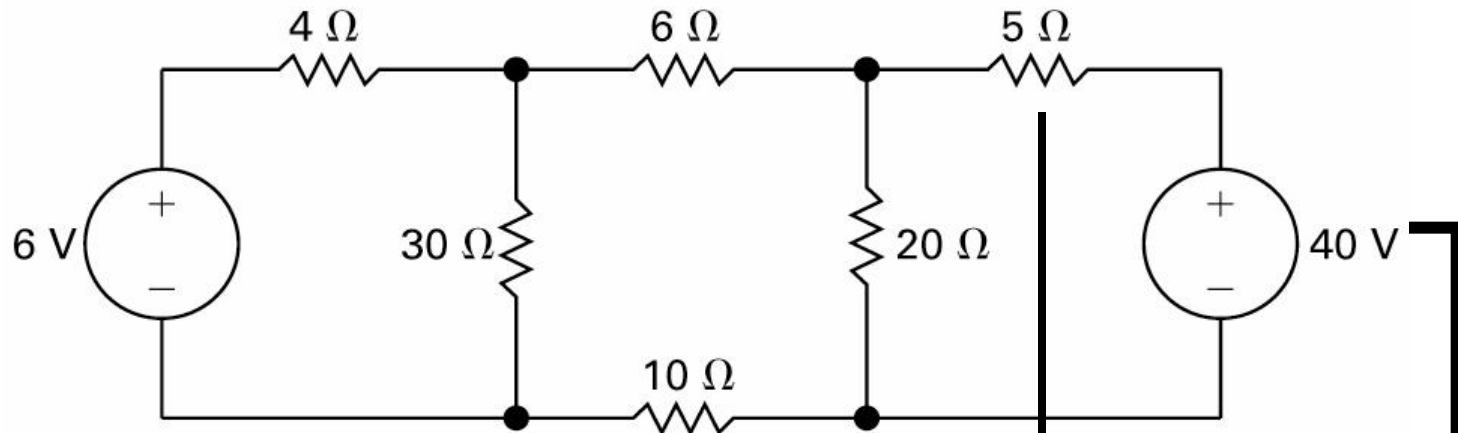

$$\frac{40}{5} = 8A$$

$$(20\Omega \parallel 5\Omega) = 4\Omega$$

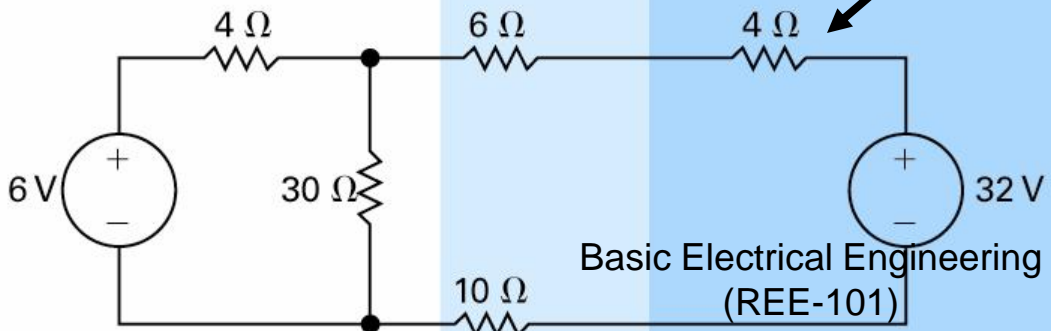

$$(8A)(4\Omega) = 32V$$

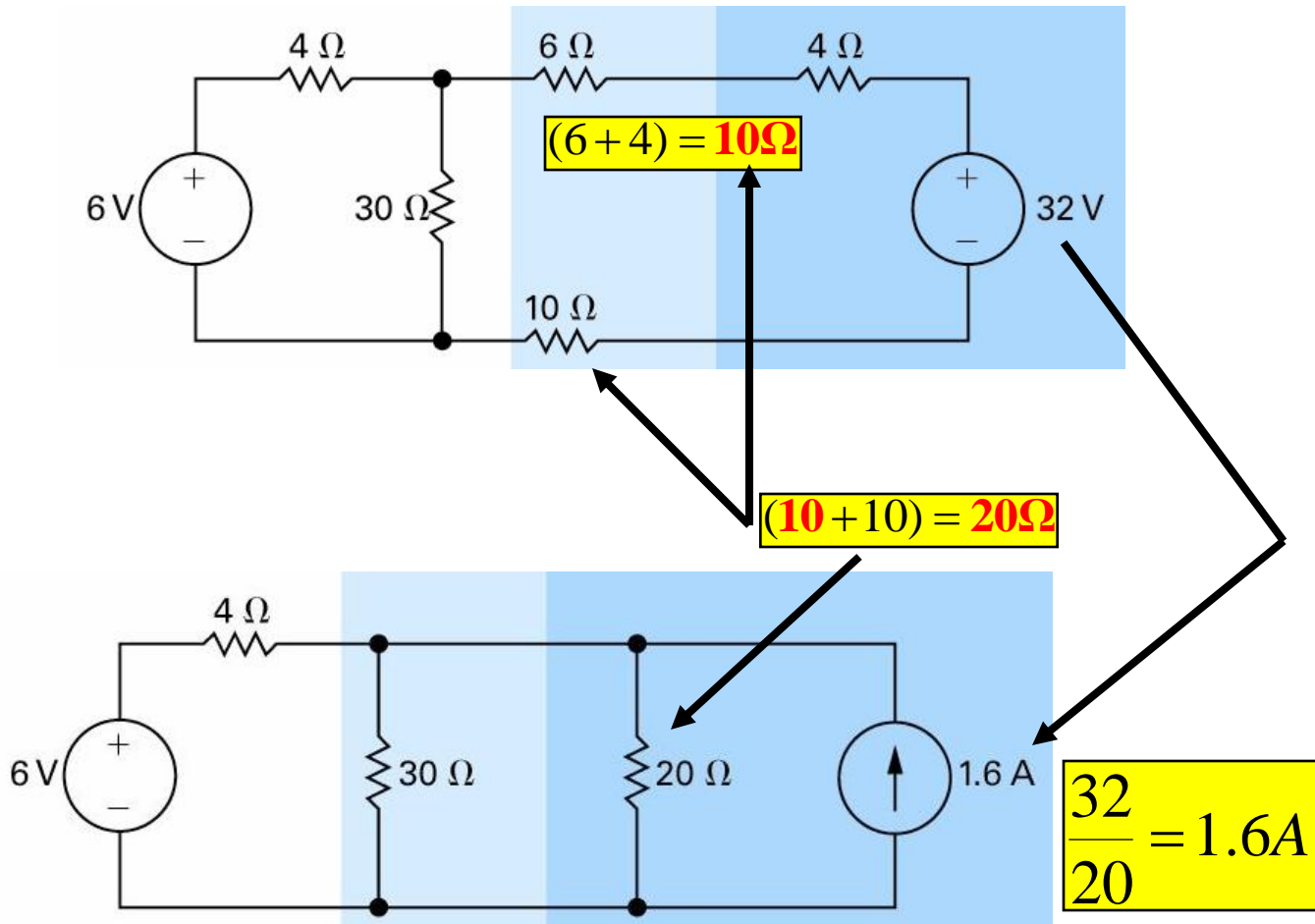

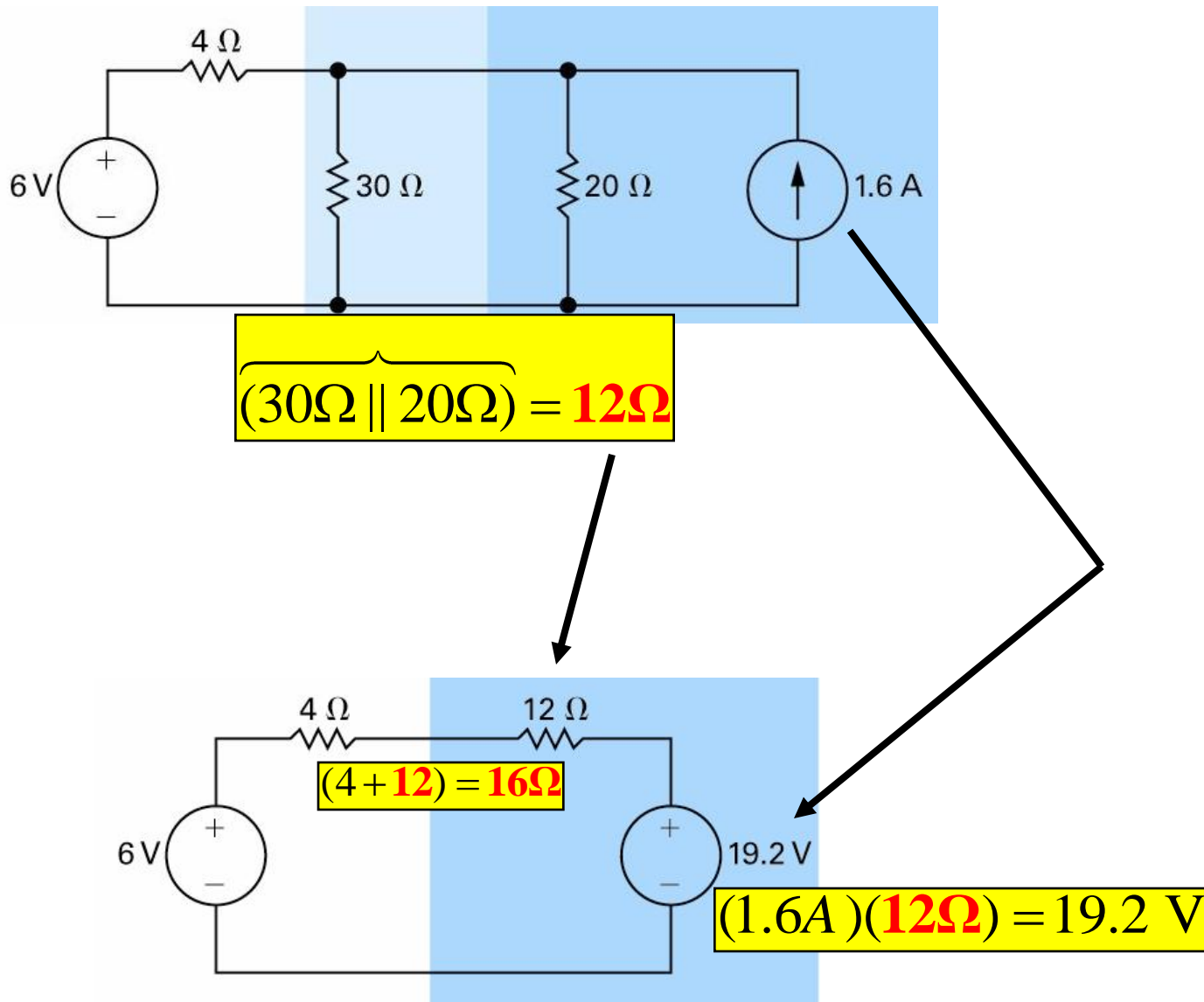

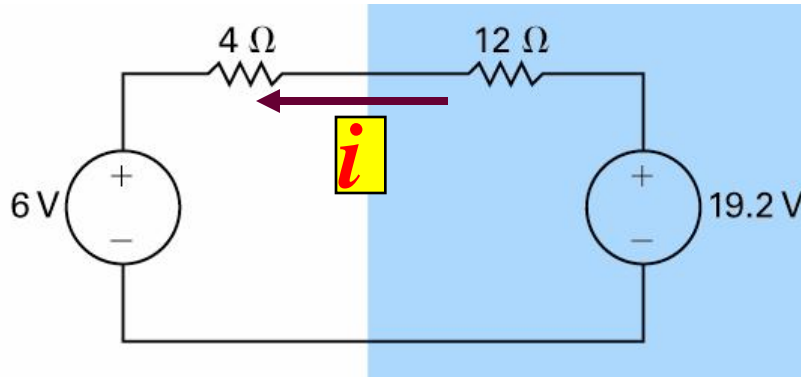

$$i = \frac{19.2 - 6}{(4 + 12)} = 0.825 \text{ A}$$

$$\Rightarrow P_{6V} = (0.825)(6) = 4.95 \text{ W}$$

It should be clear if we transfer the 6V during these steps you will not be able to find the power associated with it

Example use source transformations to find the voltage v_o ?

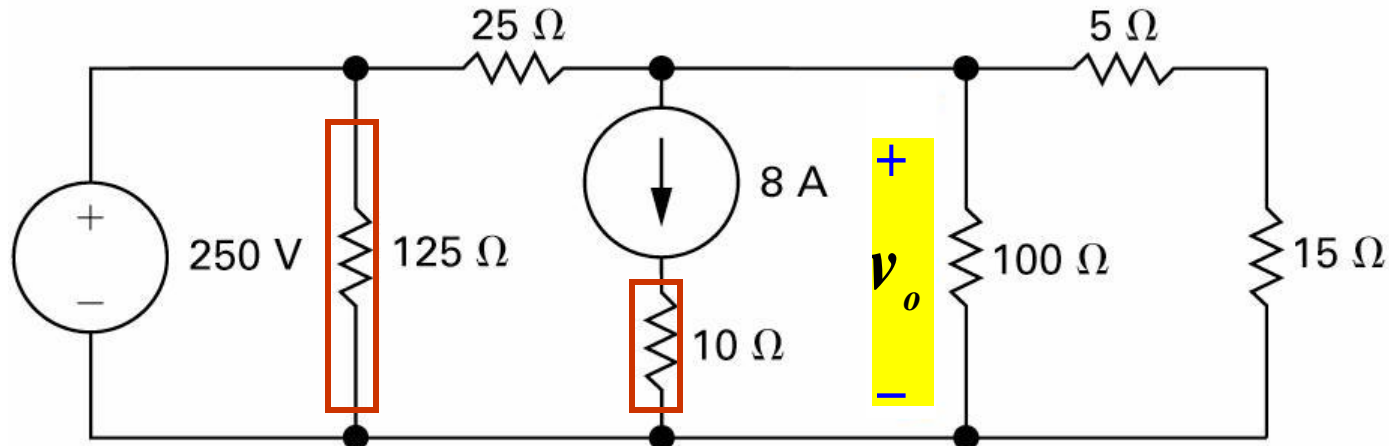

Since the **125 Ω** resistor is connected across or in parallel to the **250 V** source then we can remove it without altering any voltage or current on the circuit except the 250 V current which is not an objective any how

Our objective is v_o

Therefore we remove the **125 Ω**

Similarly the **10 Ω** resistor is connected in series with the **8 A** source then we can remove it without altering any voltage or current on the circuit

Now the circuit become

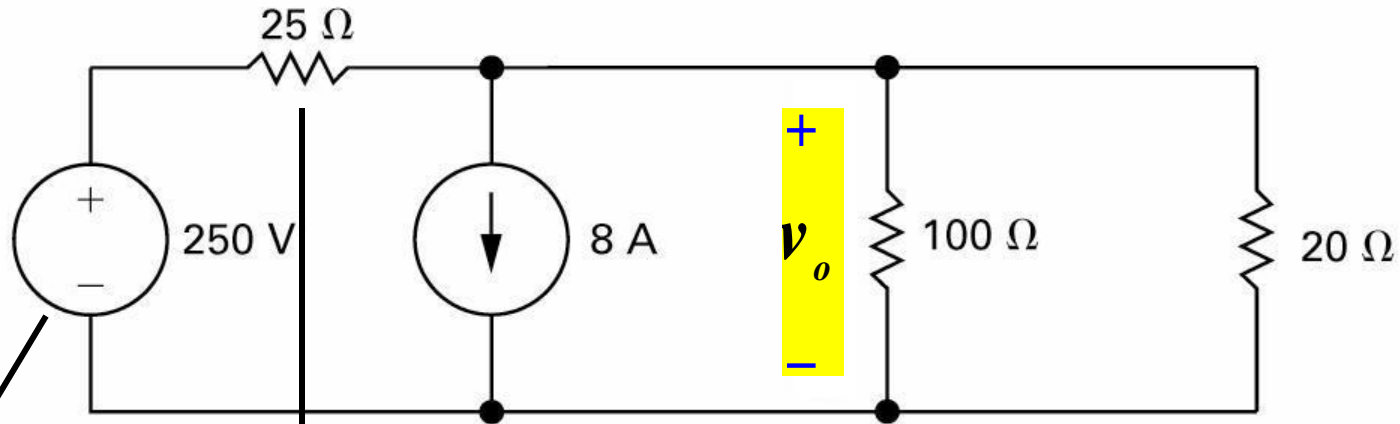

We now use the source transformation to replace the **250 V** with the **25 Ω** resistor with a current source and parallel resistor

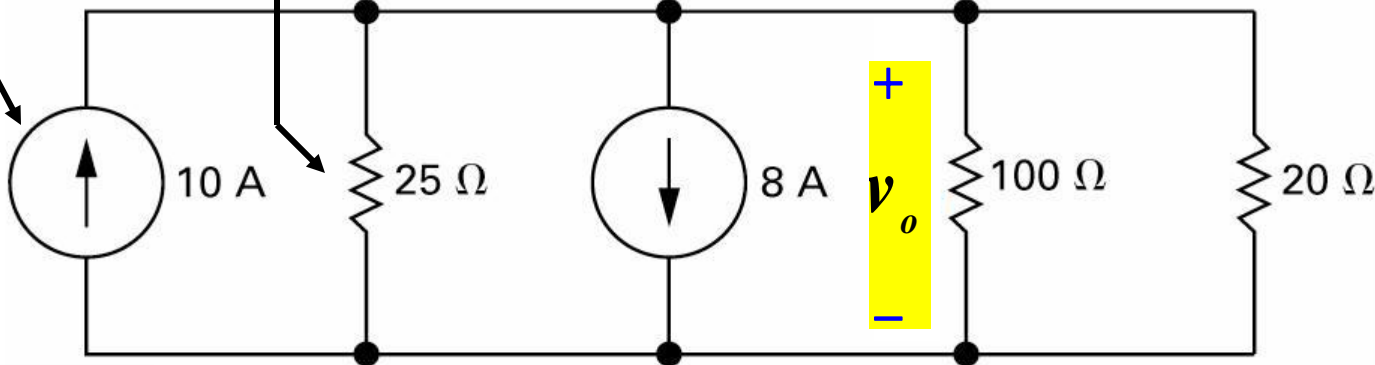

$$\frac{250}{25} = 10A$$

We now combine the parallel resistors

$$(25\Omega \parallel 100\Omega \parallel 20\Omega) = 10\Omega$$

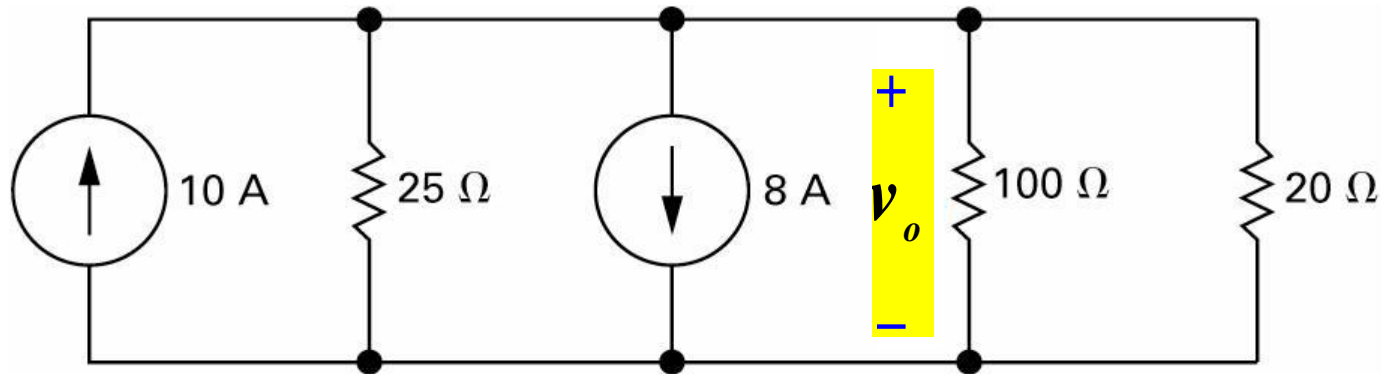

We now combine the parallel resistors

$$(25\Omega \parallel 100\Omega \parallel 20\Omega) = 10\Omega$$

The circuit now become

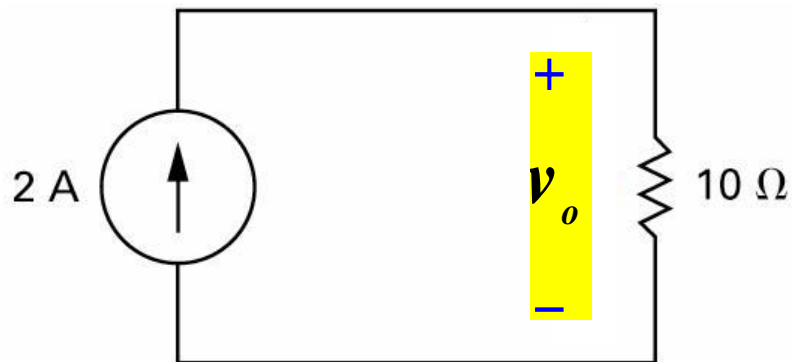

$$\Rightarrow v_o = (2A)(10\Omega) = 20\text{ V}$$