

Analysis of transistor circuits at DC

For all circuits: assume transistor operates in linear region
write B-E voltage loop
write C-E voltage loop

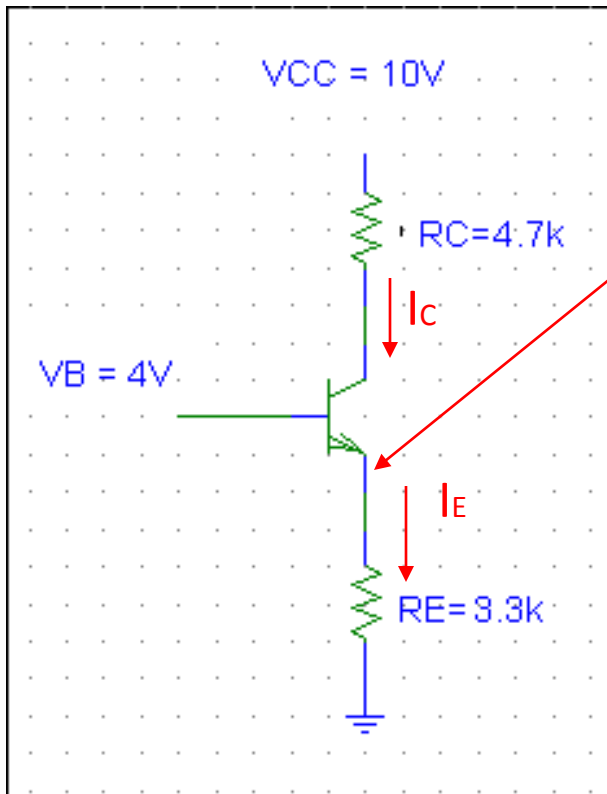

B-E junction acts like a diode

$$V_E = V_B - V_{BE} = 4V - 0.7V = 3.3V$$

$$I_E = (V_E - 0)/R_E = 3.3/3.3K = 1mA$$

$$I_C \approx I_E = 1mA$$

$$V_C = 10 - I_C R_C = 10 - 1(4.7) = 5.3V$$

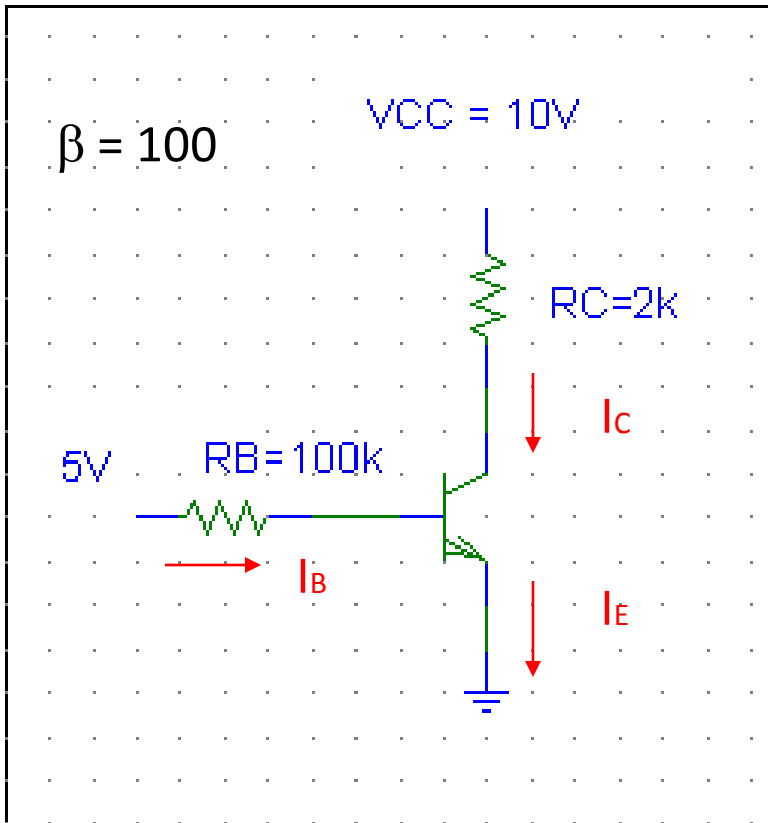

B-E Voltage loop

$$5 = I_B R_B + V_{BE}, \text{ solve for } I_B$$

$$I_B = (5 - V_{BE}) / R_B = (5 - 0.7) / 100k = 0.043mA$$

$$I_C = \beta I_B = (100) 0.043mA = 4.3mA$$

$$V_C = 10 - I_C R_C = 10 - 4.3(2) = 1.4V$$

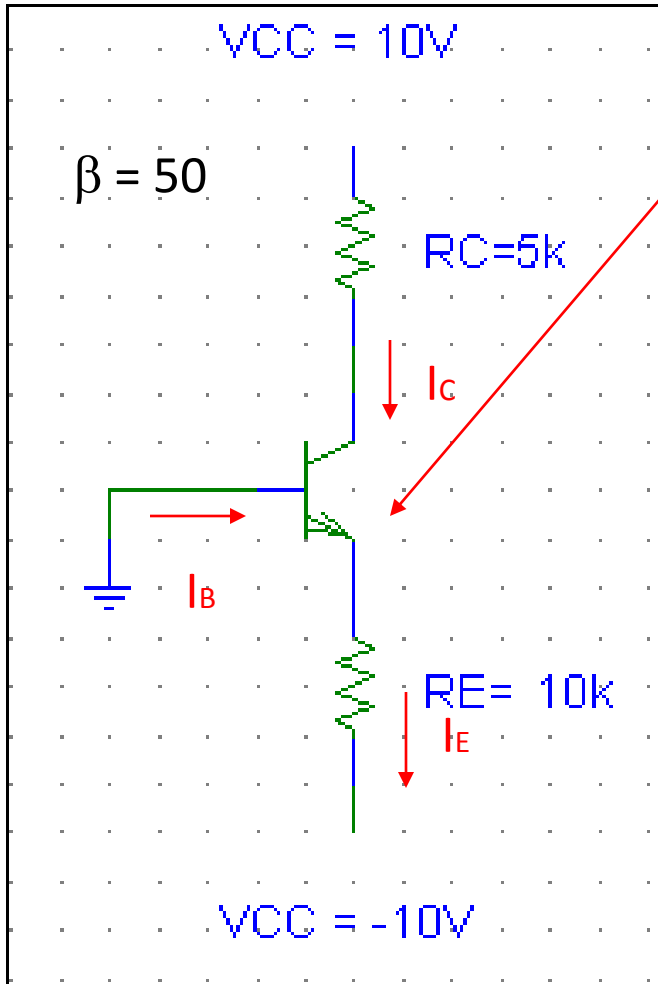

$$V_E = 0 - .7 = -0.7V$$

$$I_E = (V_E - -10)/R_E = (-.7 + 10)/10K = 0.93mA$$

$$I_C \approx I_E = 0.93mA$$

$$I_B = I_C/\beta = .93mA/50 = 18.6\mu A$$

$$V_C = 10 - I_C R_C = 10 - .93(5) = 5.35V$$