

1.

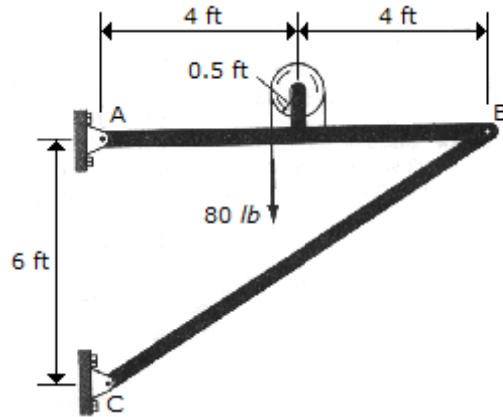

Determine the horizontal and vertical components of force at pin A.

- A. $A_x = -46.7 \text{ lb}$, $A_y = 45.0 \text{ lb}$
- B. $A_x = -53.3 \text{ lb}$, $A_y = 40.0 \text{ lb}$
- C. $A_x = 13.3 \text{ lb}$, $A_y = 10.0 \text{ lb}$
- D. $A_x = -106.7 \text{ lb}$, $A_y = 80.0 \text{ lb}$

Answer: Option A

2.

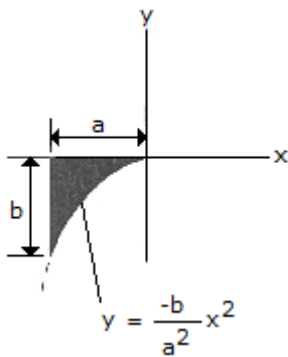

Locate the centroid of the exparabolic segment of area.

- A. $\bar{x} = -4a/5$, $\bar{y} = -b/4$
- B. $\bar{x} = -3a/4$, $\bar{y} = -3b/10$

- C. $\bar{x} = -2a/3, \bar{y} = -b/3$
- D. $\bar{x} = -5a/7, \bar{y} = -3b/8$

Answer: Option B

3.

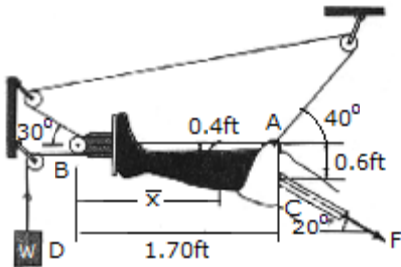

A *Russell's traction* is used for immobilizing femoral fractures *C*. If the lower leg has a weight of 8 lb, determine the weight *W* that must be suspended at *D* in order for the leg to be held in the position shown. Also, what is the tension force *F* in the femur and the distance \bar{x} which locates the center of gravity *G* of the lower leg? Neglect the size of the pulley at *B*.

- A. $x = 1.44 \text{ ft}, w = 10.8 \text{ lb}, F = 12.61 \text{ lb}$
- B. $x = 1.33 \text{ ft}, w = 15.76 \text{ lb}, F = 20.0 \text{ lb}$
- C. $x = 1.56 \text{ ft}, w = 9.75 \text{ lb}, F = 12.69 \text{ lb}$
- D. $x = 0.869 \text{ ft}, w = 6.44 \text{ lb}, F = 5.03 \text{ lb}$

Answer: Option A

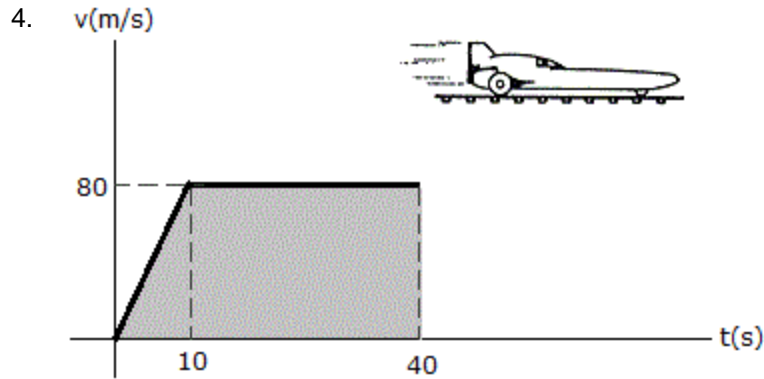

From experimental data, the motion of a jet plane while traveling along a runway is defined by the v-t graph shown. Find the position s and the acceleration a when $t = 40$ s.

- A. $s = 2.80$ km, $a = 2.00$ m/s^2
- B. $s = 2.80$ km, $a = 0$
- C. $s = 2.80$ km, $a = 2.67$ m/s^2
- D. $s = 2.80$ km, $a = 8.37$ m/s^2

Answer: Option B

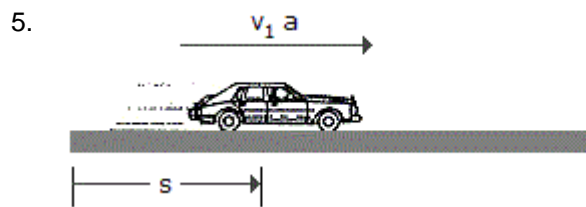

A car, initially at rest, moves along a straight road with constant acceleration such that it attains a velocity of 60 ft/s when $s = 150$ ft. Then after being subjected to *another* constant acceleration, it attains a final velocity of 100 ft/s when $s = 325$ ft. Determine the average velocity and average acceleration of the car for the entire 325-ft displacement.

- A. $v_{\text{avg}} = 80.0$ ft/s, $a_{\text{avg}} = 15.15$ ft/s^2
- B. $v_{\text{avg}} = 45.2$ ft/s, $a_{\text{avg}} = 13.91$ ft/s^2
- C. $v_{\text{avg}} = 80.0$ ft/s, $a_{\text{avg}} = 12.57$ ft/s^2

- D. $v_{\text{avg}} = 55.0 \text{ ft/s}$, $a_{\text{avg}} = 15.15 \text{ ft/s}^2$

Answer: Option B

6.

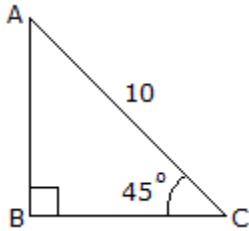

Using the basic trigonometric functions, determine the length of side AB of the right triangle.

- A. $h = 7.07$
- B. $h = 10$
- C. $h = 5$
- D. $h = 14.14$

Answer: Option A

7.

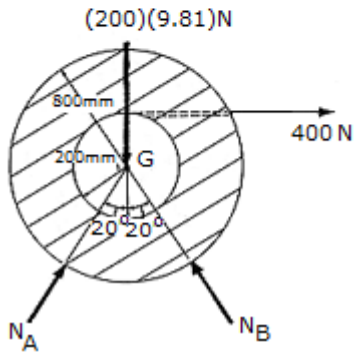
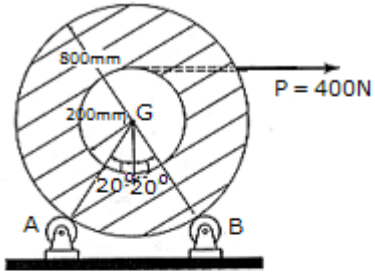

The spool of cable, originally at rest, has a mass of 200 kg and a radius of gyration of $k_G = 325$ mm. If the spool rests on two small rollers A and B and a constant horizontal force of $P = 400$ N is applied to the end of the cable, compute the angular velocity of the spool when 8 m of cable has been unraveled. Neglect friction and the mass of the rollers and unraveled cable.

- A. $\omega = 10.00$ rad/s
- B. $\omega = 12.31$ rad/s
- C. $\omega = 17.41$ rad/s
- D. $\omega = 40.0$ rad/s

Answer: Option C

8.

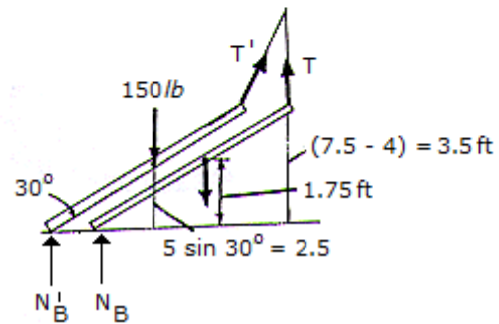
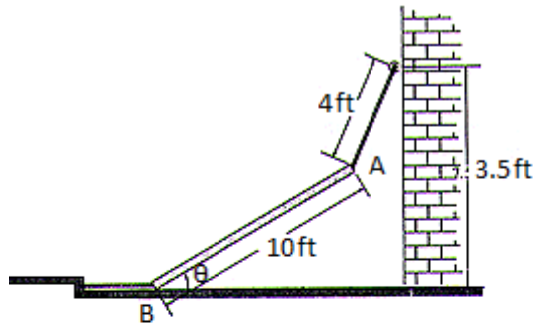

The beam having a weight of 150 lb is supported by two cables. If the cable at end B is cut so that the beam is released from rest when $\theta = 30^\circ$, determine the speed at which end A strikes the wall. Neglect friction at B . Consider the beam to be a thin rod.

- A. $v_A = 5.87 \text{ ft/s}$
- B. $v_A = 7.43 \text{ ft/s}$
- C. $v_A = 10.18 \text{ ft/s}$
- D. $v_A = 6.95 \text{ ft/s}$

Answer: Option D

9.

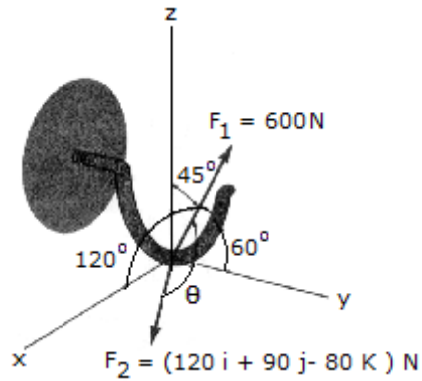

Two forces act on a block. Determine the angle θ between them.

- A. $\theta = 135.0^\circ$
- B. $\theta = 65.1^\circ$
- C. $\theta = 45.0^\circ$
- D. $\theta = 114.9^\circ$

Answer: Option D

10.

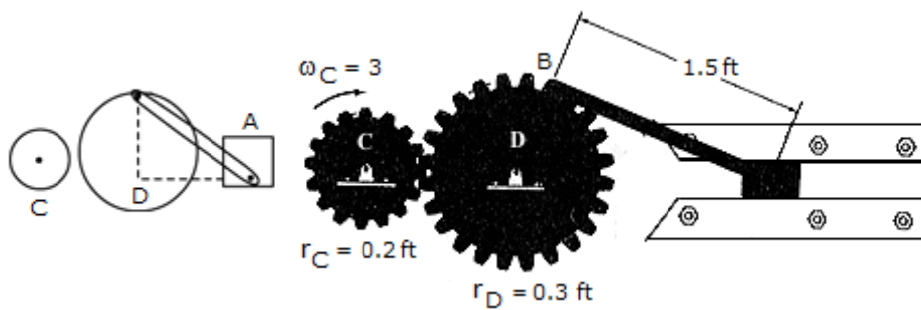

Gear C is rotating with a constant angular velocity of $\omega_c = 3 \text{ rad/s}$. Determine the acceleration of the piston A and the angular acceleration of rod AB at the instant $\theta = 90^\circ$. Set $r_c = 0.2 \text{ ft}$ and $r_d = 0.3 \text{ ft}$.

- A. $a_A = 5.88 \text{ ft/s}^2 \uparrow$, $\alpha_{AB} = 4.00 \text{ rad/s}^2 \curvearrowright$
- B. $a_A = 5.88 \text{ ft/s}^2 \downarrow$, $\alpha_{AB} = 4.00 \text{ rad/s}^2 \curvearrowright$
- C. $a_A = 0.245 \text{ ft/s}^2 \uparrow$, $\alpha_{AB} = 0.816 \text{ rad/s}^2 \curvearrowright$

- D. $a_A = 0.245 \text{ ft/s}^2$, $\alpha_{AB} = 0.816 \text{ rad/s}^2$

Answer: Option C

11.

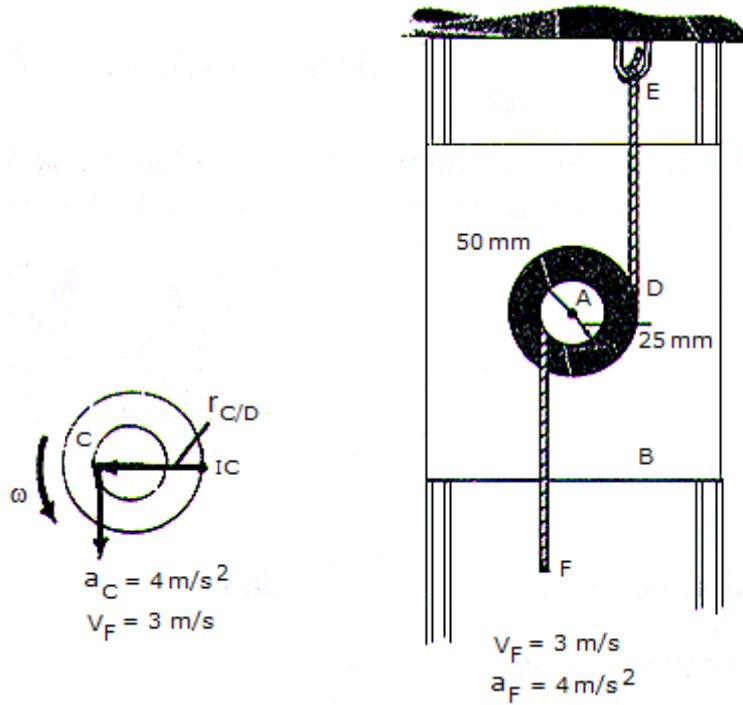

The pulley is pin-connected to block B at A . As cord CF unwinds from the inner hub with the motion shown, cord DE unwinds from the outer rim. Determine the angular acceleration of the pulley at the instant shown.

- A. $\alpha = 80.0 \text{ rad/s}^2$
- B. $\alpha = 160.0 \text{ rad/s}^2$
- C. $\alpha = 180.0 \text{ rad/s}^2$
- D. $\alpha = 53.3 \text{ rad/s}^2$

Answer: Option D

12.

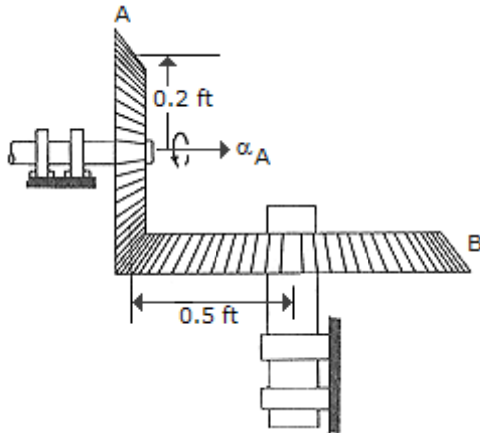

Gear A is in mesh with gear B as shown. If A starts from rest and has a constant angular acceleration of $\alpha_A = 2 \text{ rad/s}^2$, determine the time needed for B to attain an angular velocity of $\omega_B = 50 \text{ rad/s}$.

- A. $t = 62.5 \text{ s}$
- B. $t = 250.0 \text{ s}$
- C. $t = 10.00 \text{ s}$
- D. $t = 40.0 \text{ s}$

Answer: Option A

13.

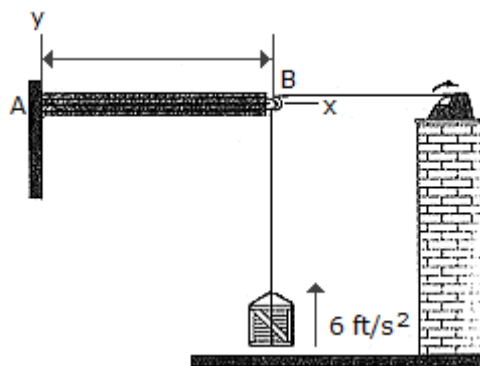

The 30-lb crate is being hoisted upward with a constant acceleration of 6 ft/s^2 . If the uniform beam AB has a weight of 200 lb, determine the components of reaction at A. Neglect the size and mass of the pulley at B.

- A. $A_x = -48.3 \text{ lb}$, $A_y = 248.3 \text{ lb}$, $M_A = 258 \text{ lb-ft CCW}$

- B. $A_x = -48.3 \text{ lb}$, $A_y = 248.3 \text{ lb}$, $M_A = 741 \text{ lb-ft CCW}$
- C. $A_x = -35.6 \text{ lb}$, $A_y = 236 \text{ lb}$, $M_A = 678 \text{ lb-ft CCW}$
- D. $A_x = -30.0 \text{ lb}$, $A_y = 230 \text{ lb}$, $M_A = 650 \text{ lb-ft CCW}$

Answer: Option C

14.

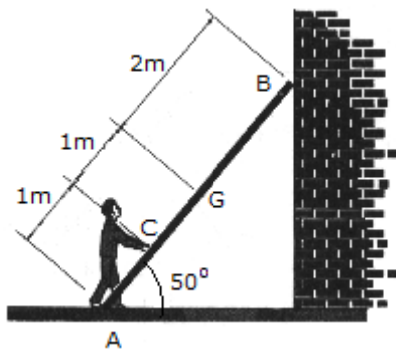

A 17-kg ladder has a center of mass at G. If the coefficients of friction at A and B are $\mu_A = 0.3$ and $\mu_B = 0.2$, respectively, determine the smallest horizontal force that the man must exert of the ladder at point C in order to push the ladder forward.

- A. $F = 120.2 \text{ N}$
- B. $F = 288 \text{ N}$
- C. $F = 166.8 \text{ N}$
- D. $F = 204 \text{ N}$

Answer: Option D

15.

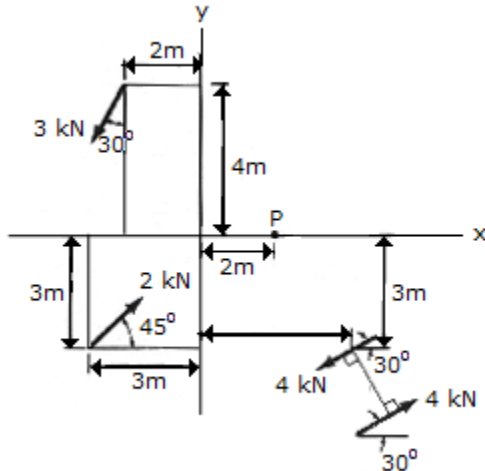

Replace the force and couple system by an equivalent single force and couple acting at point P .

- A. $\mathbf{F} = (-0.0858\mathbf{i} - 1.184\mathbf{j})$ kN, $M = 36.6$ kN-m \curvearrowright
- B. $\mathbf{F} = (-0.0858\mathbf{i} - 1.184\mathbf{j})$ kN, $M = 21.6$ kN-m \curvearrowright
- C. $\mathbf{F} = (-0.0858\mathbf{i} - 1.184\mathbf{j})$ kN, $M = 13.61$ kN-m \curvearrowright
- D. $\mathbf{F} = (-0.0858\mathbf{i} - 1.184\mathbf{j})$ kN, $M = 35.7$ kN-m \curvearrowright

Answer: Option A

16.

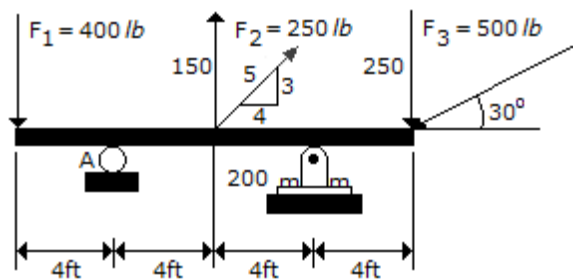

Determine the moment of force F_3 about point A on the beam.

- A. $M_3 = 6930$ ft-lb \curvearrowright
- B. $M_3 = 6000$ ft-lb \curvearrowright

C. $M_3 = 3000 \text{ ft-lb}$ 

D. $M_3 = 4000 \text{ ft-lb}$ 

Answer: Option C

17.

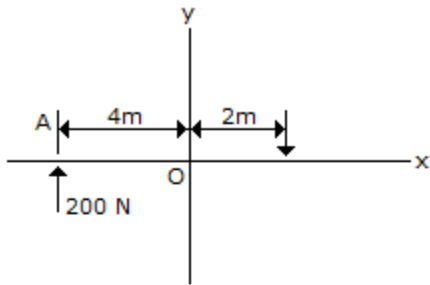

(a)

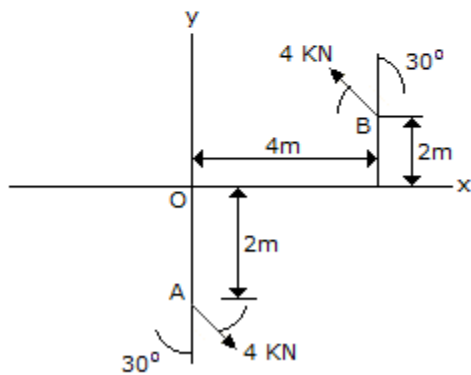

(b)

Determine the magnitude and direction of the couple shown.

A. $M = 22.6 \text{ kN-m}$ CCW

B. $M = 22.6 \text{ kN-m}$ CW

C. $M = 21.9 \text{ kN-m}$ CCW

D. $M = 21.9 \text{ kN-m}$ CW

Answer: Option C

18.

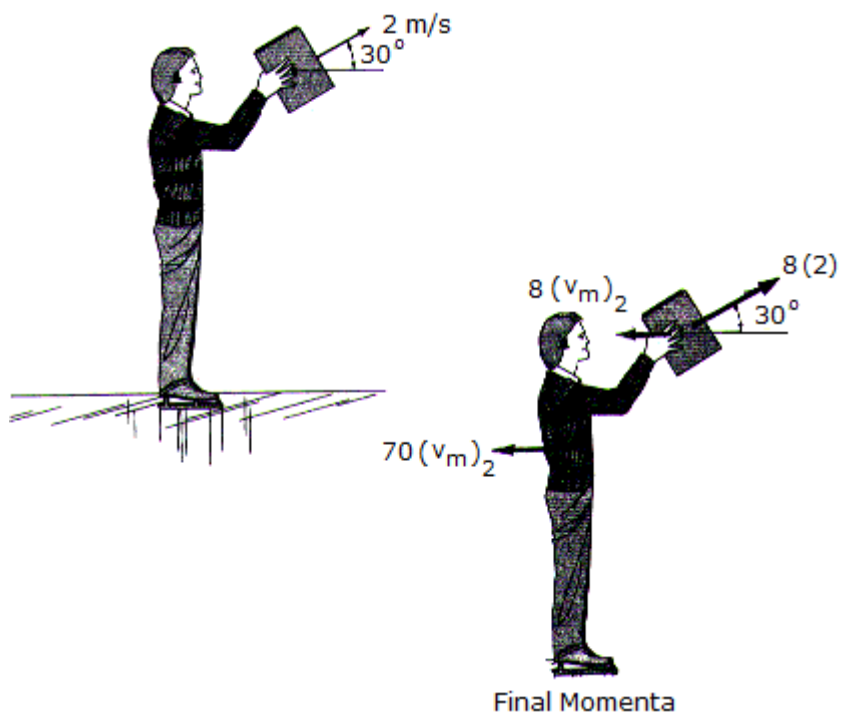

A man wearing ice skates throws an 8-kg block with an initial velocity of 2 m/s, measured relative to himself, in the direction shown. If he is originally at rest and completes the throw in 1.5 s while keeping his legs rigid, determine the horizontal velocity of the man just after releasing the block. What is the average vertical reaction of both his skates on the ice during the throw? The man has a mass of 70 kg. Neglect friction and the motion of his arms.

- A. $v_{\text{man}} = 0.1776 \text{ m/s}$, $N_{\text{avg}} = 765 \text{ N}$
- B. $v_{\text{man}} = 0.1979 \text{ m/s}$, $N_{\text{avg}} = 771 \text{ N}$
- C. $v_{\text{man}} = 0.1776 \text{ m/s}$, $N_{\text{avg}} = 771 \text{ N}$
- D. $v_{\text{man}} = 0.1979 \text{ m/s}$, $N_{\text{avg}} = 765 \text{ N}$

Answer: Option C

19.

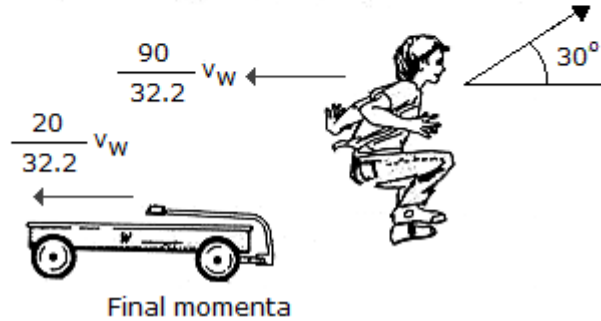
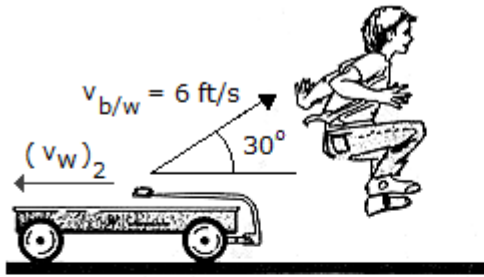

A boy, having a weight of 90 lb, jumps off a wagon with a relative velocity of $v_{b/w} = 6 \text{ ft/s}$. If the angle of jump is 30° , determine the horizontal velocity $(v_w)_2$ of the wagon just after the jump. Originally both the wagon and the boy are at rest. Also, compute the total average impulsive force that all four wheels of the wagon exert on the ground of the boy jumps off in $\Delta t = 0.8 \text{ s}$. The wagon has a weight of 20 lb.

- A. $v_{\text{wagon}} = 23.4 \text{ ft/s}$ $N_{\text{wheel}} = 110.0 \text{ lb}$
- B. $v_{\text{wagon}} = 23.4 \text{ ft/s}$ $N_{\text{wheel}} = 120.5 \text{ lb}$
- C. $v_{\text{wagon}} = 4.25 \text{ ft/s}$ $N_{\text{wheel}} = 120.5 \text{ lb}$
- D. $v_{\text{wagon}} = 4.25 \text{ ft/s}$ $N_{\text{wheel}} = 110.0 \text{ lb}$

Answer: Option C

20.

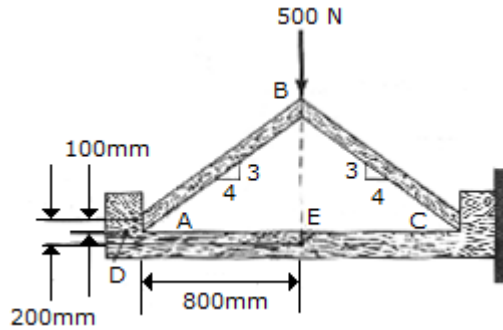

A force of 500 N acts at the top of the two-member frame. If the members are in smooth contact with one another at A , B , and C with no fasteners, determine the shear force developed at a horizontal section through point D of the support. Also, what are the axial force, shear force and moment at point E ?

- A. $V_D = 250 \text{ N}$, $A_E = 250 \text{ N}$, $V_E = 333 \text{ N}$, $M_E = 316 \text{ N-m}$
- B. $V_D = 333 \text{ N}$, $A_E = 333 \text{ N}$, $V_E = 250 \text{ N}$, $M_E = 267 \text{ N-m}$
- C. $V_D = 333 \text{ N}$, $A_E = 333 \text{ N}$, $V_E = 250 \text{ N}$, $M_E = 200 \text{ N-m}$
- D. $V_D = 250 \text{ N}$, $A_E = 250 \text{ N}$, $V_E = 333 \text{ N}$, $M_E = 267 \text{ N-m}$

Answer: Option B

21. Solve the following equation for x , y , and z :

$$x - y + z = -1 \quad -x + y + z = -1 \quad x + 2y - 2z = 5$$

- A. $x = 1$, $y = 1$, $z = -1$
- B. $x = 5/3$, $y = 7/6$, $z = -1/2$
- C. $x = -2/3$, $y = -2/3$, $z = -1$
- D. $x = -1$, $y = 1$, $z = 1$

Answer: Option A

22.

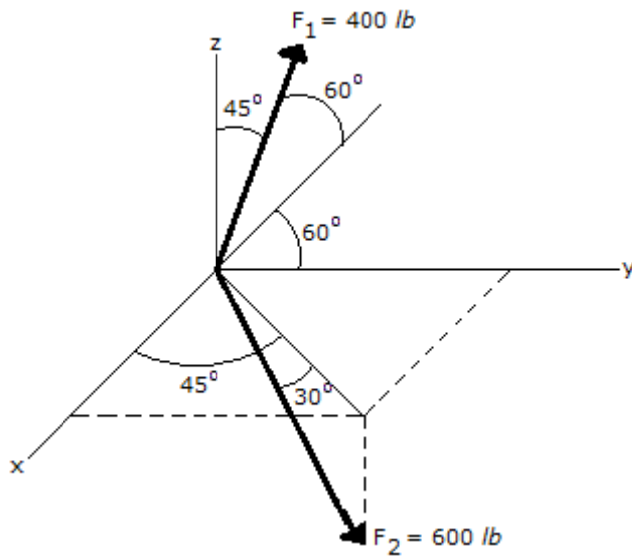

Express the force F_1 in Cartesian vector form.

- A. $F_1 = (200 \mathbf{i} - 200 \mathbf{j} + 283 \mathbf{k}) \text{ lb}$
- B. $F_1 = (200 \mathbf{i} + 200 \mathbf{j} + 283 \mathbf{k}) \text{ lb}$
- C. $F_1 = (-200 \mathbf{i} + 200 \mathbf{j} + 565 \mathbf{k}) \text{ lb}$
- D. $F_1 = (-200 \mathbf{i} + 200 \mathbf{j} + 283 \mathbf{k}) \text{ lb}$

Answer: Option D

23.

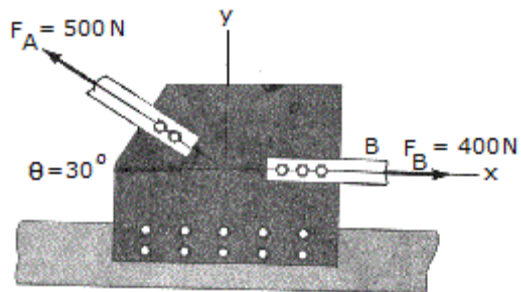

The *gusset plate* G of a bridge joint is subjected to the two member forces at A and B . If the force at B is horizontal and the force at A is directed at $\theta = 30^\circ$, determine the magnitude and direction of the resultant force.

- A. $R = 458 \text{ N}$, $\phi = 97.5^\circ \text{ CCW}$
- B. $R = 252 \text{ N}$, $\phi = 82.5^\circ \text{ CCW}$
- C. $R = 252 \text{ N}$, $\phi = 97.5^\circ \text{ CCW}$
- D. $R = 458 \text{ N}$, $\phi = 82.5^\circ \text{ CCW}$

Answer: Option C

24.

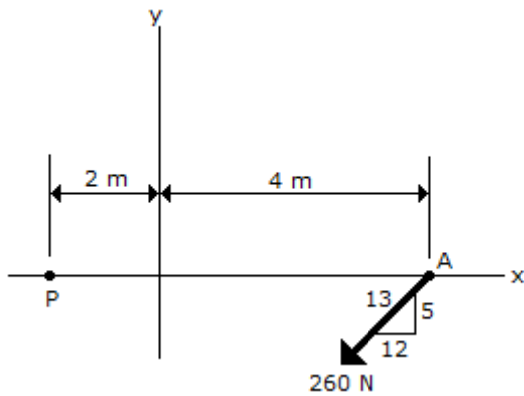

Determine the magnitude and direction of the moment of the force of the movement if the force at A about point P.

- A. $M_p = 1440 \text{ Nm}$ ↻
- B. $M_p = 600 \text{ Nm}$ ↻
- C. $M_p = 1440 \text{ Nm}$ ↻
- D. $M_p = 600 \text{ Nm}$ ↻

Answer: Option D

25.

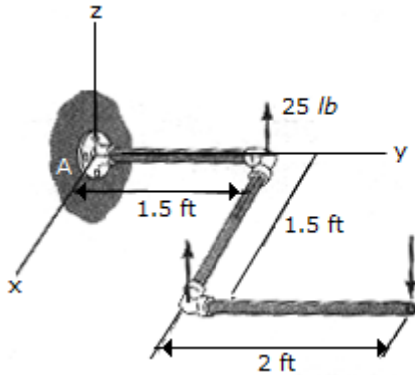

A force and couple act on the pipe assembly. Replace this system by an equivalent single resultant force. Specify the location of the resultant force along the y axis, measured from A. The pipe lies in the x - y plane.

- A. $R = 25\text{k lb}$, $y = -0.9\text{ ft}$
- B. $R = 25\text{k lb}$, $y = 0.9\text{ ft}$
- C. $R = 25\text{k lb}$, $y = 3.9\text{ ft}$
- D. $R = 25\text{k lb}$, $y = -3.9\text{ ft}$

Answer: Option A

26.

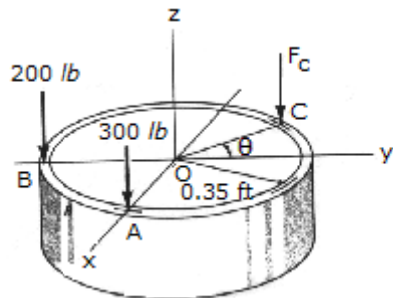

Three parallel forces act on the rim of the tube. If it is required that the resultant force F_R of the system have a line of action that coincides with the central z axis, determine the magnitude of F_C and its location θ on the rim. What is the magnitude of the resultant force F_R ?

- A. $F_C = 361\text{ lb}$, $\theta = 56.3^\circ$, $R = 861\text{ lb}$
- B. $F_C = 500\text{ lb}$, $\theta = 54.0^\circ$, $R = 1000\text{ lb}$

C. $F_c = 500 \text{ lb}$, $\theta = 36.0^\circ$, $R = 1000 \text{ lb}$

D. $F_c = 361 \text{ lb}$, $\theta = 36.9^\circ$, $R = 861 \text{ lb}$

Answer: Option A

27.

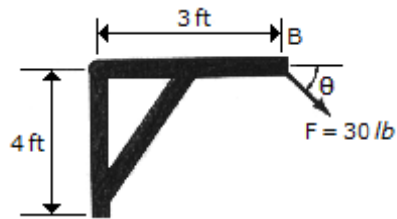

Determine the direction ($0^\circ \leq \theta \leq 180^\circ$) of the 30-lb force F so that the moment of F about point A has the minimum magnitude.

A. $\theta = 36.9^\circ$

B. $\theta = 53.1^\circ$

C. $\theta = 127.0^\circ$

D. $\theta = 90.0^\circ$

Answer: Option C

28.

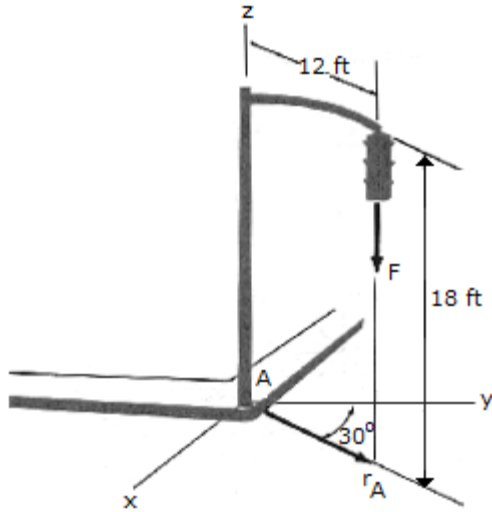

The pole supports a 22-lb traffic light. Using Cartesian vectors, determine the moment of the weight of the traffic light about the base of the pole at A.

- A. $\mathbf{M}_A = 216\mathbf{k}$ lb-ft
- B. $\mathbf{M}_A = (-132\mathbf{i} - 229\mathbf{j} - 216\mathbf{k})$ lb-ft
- C. $\mathbf{M}_A = (-229\mathbf{i} + 121\mathbf{j})$ lb-ft
- D. $\mathbf{M}_A = (-132\mathbf{i} + 229\mathbf{j})$ lb-ft

Answer: Option C

29.

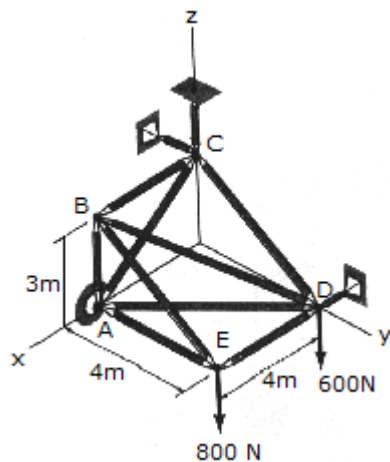

The space truss is supported by a ball-and-socket joint at A and short links, two at C and one at D. Determine the x, y, z components of reaction at A and the force in each link.

- A. $A_x = -1.050 \text{ kN}$, $A_y = 1.050 \text{ kN}$, $A_z = 0.800 \text{ kN}$, $C_y = -1.050 \text{ kN}$, $C_z = 0.600 \text{ kN}$, $D_x = 1.050 \text{ kN}$
- B. $A_x = -1.400 \text{ kN}$, $A_y = 1.400 \text{ kN}$, $A_z = 0.800 \text{ kN}$, $C_y = -1.400 \text{ kN}$, $C_z = 0.600 \text{ kN}$, $D_x = 1.400 \text{ kN}$
- C. $A_x = -2.49 \text{ kN}$, $A_y = 1.867 \text{ kN}$, $A_z = 0.800 \text{ kN}$, $C_y = -2.49 \text{ kN}$, $C_z = 0.600 \text{ kN}$, $D_x = 2.49 \text{ kN}$
- D. $A_x = -1.867 \text{ kN}$, $A_y = 1.867 \text{ kN}$, $A_z = 0.800 \text{ kN}$, $C_y = -1.867 \text{ kN}$, $C_z = 0.600 \text{ kN}$, $D_x = 1.867 \text{ kN}$

Answer: Option D

30.

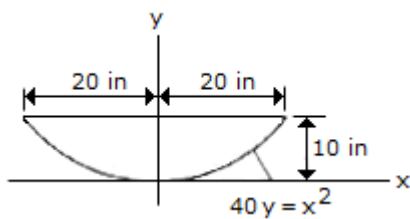

Determine the inertia of the parabolic area about the x axis.

- A. $I_x = 11,430 \text{ in.}^4$
- B. $I_x = 32,800 \text{ in.}^4$
- C. $I_x = 13,330 \text{ in.}^4$
- D. $I_x = 21,300 \text{ in.}^4$

Answer: Option A

31.

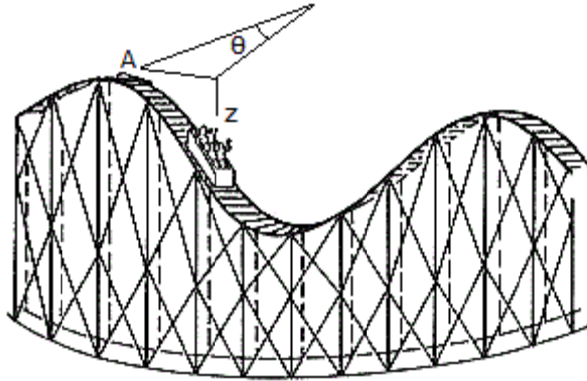

For a short time the position of a roller-coaster car along its path is defined by the equations $r = 25$ m, $\theta = (0.3t)$ rad, and $z = (-8 \cos \theta)$ m, where t is measured in seconds. Determine the magnitudes of the car's velocity and acceleration when $t = 4$ s.

- A. $v = 7.83$ m/s, $a = 2.27$ m/s²
- B. $v = 9.74$ m/s, $a = 2.51$ m/s²
- C. $v = 7.50$ m/s, $a = 2.25$ m/s²
- D. $v = 5.26$ m/s, $a = 1.989$ m/s²

Answer: Option A

32.

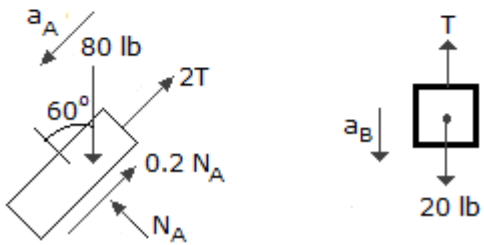
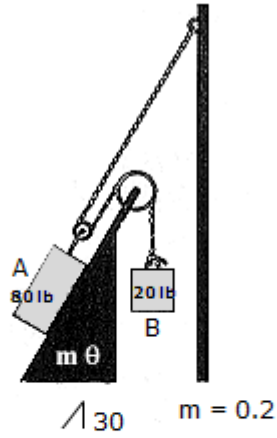

Determine the acceleration of block A when the system is released. The coefficient of friction and the weight of each block are indicated in the figure. Neglect the mass of the pulleys and cords.

- A. $a_A = 7.50 \text{ ft/s}^2$ Up the slope
- B. $a_A = 7.50 \text{ ft/s}^2$ Down the slope
- C. $a_A = 4.28 \text{ ft/s}^2$ Up the slope
- D. $a_A = 4.28 \text{ ft/s}^2$ Down the slope

Answer: Option D

33.

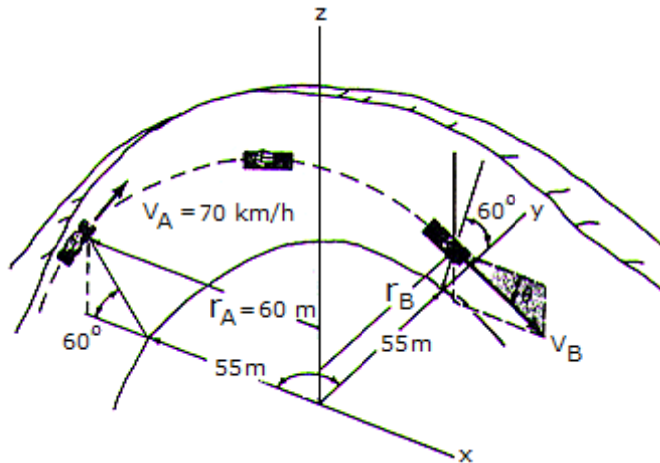

A toboggan and rider, having a total mass of 150 kg, enter horizontally tangent to a 90° circular curve with a velocity V_A and the angle θ of "descent," measured from the horizontal in a vertical $x-z$ plane, at which the toboggan exits at B . Neglect friction in the calculation. The radius r_B equals 57 m.

- A. $v_B = 21.9 \text{ m/s}$, $\theta = 20.9^\circ$
- B. $v_B = 23.4 \text{ m/s}$, $\theta = 29.0^\circ$
- C. $v_B = 20.7 \text{ m/s}$, $\theta = 8.84^\circ$
- D. $v_B = 20.3 \text{ m/s}$, $\theta = 7.37^\circ$

Answer: Option A

34.

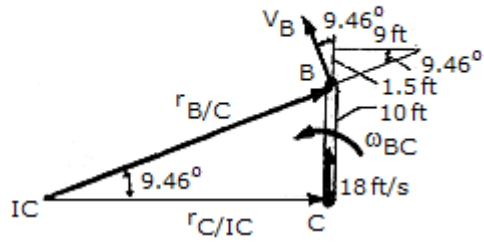
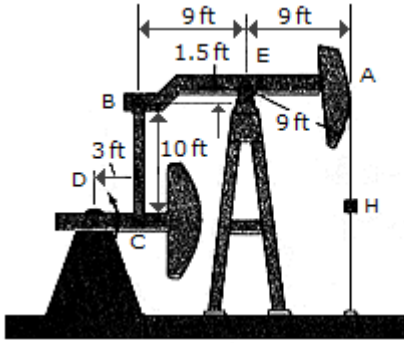

The oil pumping unit consists of a walking beam AB , connecting rod BC , and crank CD . If the crank rotates at a constant rate of 6 rad/s , determine the speed of the rod hanger H at the instant shown.

- A. $v_H = 17.76 \text{ ft/s}$
- B. $v_H = 16.20 \text{ ft/s}$
- C. $v_H = 18.00 \text{ ft/s}$
- D. $v_H = 16.42 \text{ ft/s}$

Answer: Option C

35.

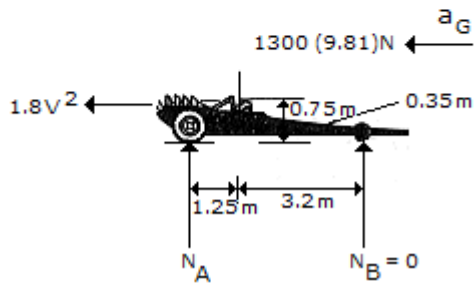
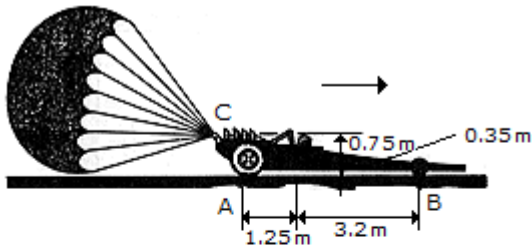

The dragster has a mass of 1.3 Mg and a center of mass at G. If a braking parachute is attached at C and provides a horizontal braking force F_D , determine the maximum deceleration the dragster can have upon releasing the parachute without tipping the dragster over backwards (i.e., the normal force under the wheels and assume that the engine is disengaged so that the wheels are freely rolling.

- A. $a = 16.35 \text{ m/s}^2$
- B. $a = 8.46 \text{ m/s}^2$
- C. $a = 2.75 \text{ m/s}^2$
- D. $a = 35.0 \text{ m/s}^2$

Answer: Option A

36.

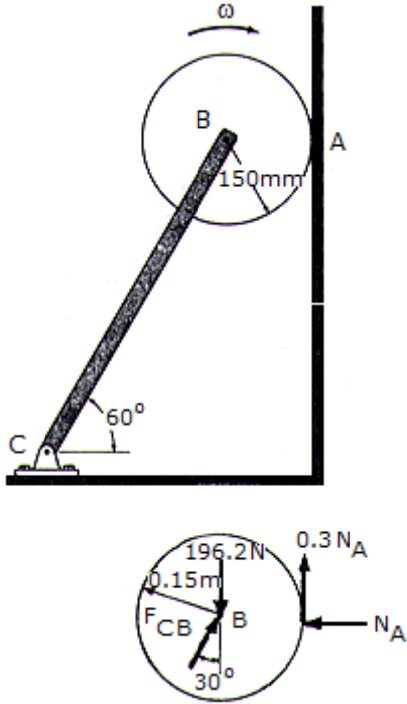

The disk has a mass of 20 kg and is originally spinning at the end of the massless strut with an angular velocity of $\omega = 60$ rad/s. If it is then placed against the wall, for which $\mu_A = 0.3$, determine the time required for the motion to stop. What is the force in strut BC during this time?

- A. $t = 3.11$ s, $F_{BC} = 193.1$ N
- B. $t = 2.65$ s, $F_{BC} = 227$ N
- C. $t = 5.30$ s, $F_{BC} = 227$ N
- D. $t = 6.21$ s, $F_{BC} = 193.1$ N

Answer: Option A

37.

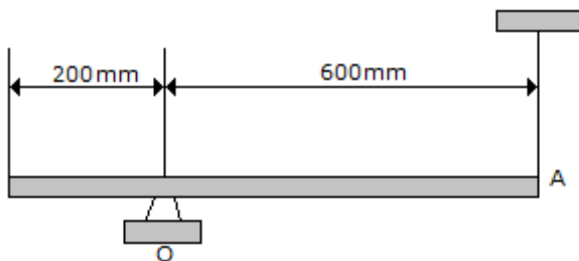

The uniform slender rod has a mass of 5 kg. Determine the magnitude of the reaction at the

pin O when the cord at A is cut and $\theta = 90^\circ$

- A. $O = 42.0 \text{ N}$
- B. $O = 91.1 \text{ N}$
- C. $O = 122.6 \text{ N}$
- D. $O = 67.4 \text{ N}$

Answer: Option B

38.

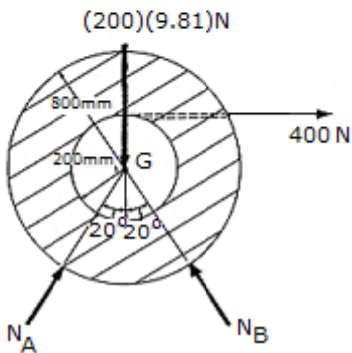
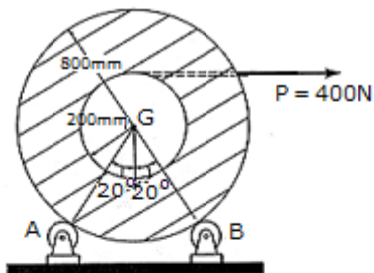

The spool of cable, originally at rest, has a mass of 200 kg and a radius of gyration of $k_G = 325 \text{ mm}$. If the spool rests on two small rollers A and B and a constant horizontal force of $P = 400 \text{ N}$ is applied to the end of the cable, compute the angular velocity of the spool when 8 m of cable has been unraveled. Neglect friction and the mass of the rollers and unraveled cable.

- A. $\omega = 10.00 \text{ rad/s}$
- B. $\omega = 12.31 \text{ rad/s}$

- C. $\omega = 17.41 \text{ rad/s}$
- D. $\omega = 40.0 \text{ rad/s}$

Answer: Option C

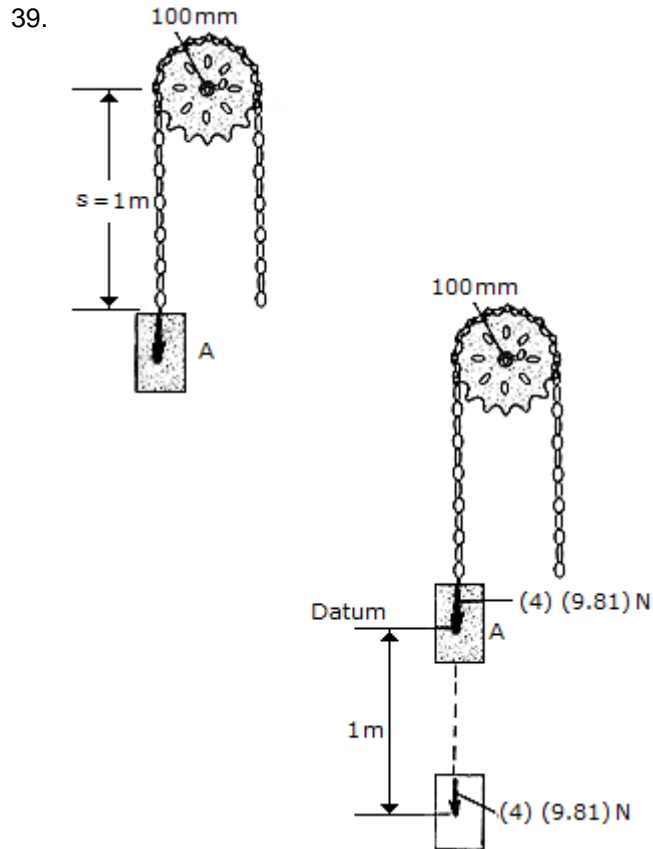

A chain that has a negligible mass is draped over a sprocket which has a mass of 2 kg and a radius of gyration of $k_O = 50 \text{ mm}$. If the 4-kg block A is released from rest in the position shown, $s = 1 \text{ m}$, determine the angular velocity which the chain imparts to the sprocket when $s = 2 \text{ m}$.

- A. $\omega = 44.3 \text{ rad/s}$
- B. $\omega = 39.6 \text{ rad/s}$
- C. $\omega = 41.8 \text{ rad/s}$
- D. $\omega = 59.1 \text{ rad/s}$

Answer: Option C

40.

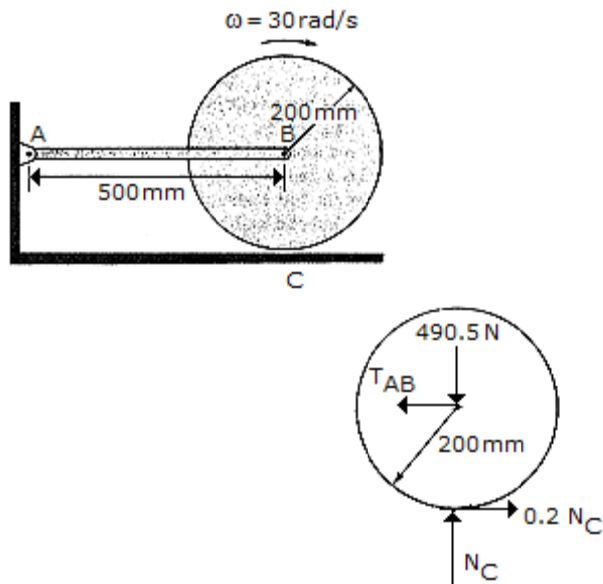

The 50-kg cylinder has an angular velocity of 30 rad/s when it is brought into contact with the horizontal surface at C. If the coefficient of friction is $\mu_c = 0.2$, determine how long it takes for the cylinder to stop spinning. What force is developed at the pin A during this time? The axis of the cylinder is connected to two symmetrical links. (Only AB is shown.) For the computation, neglect the weight of the links.

- A. $t = 1.529 \text{ s}$, $A = 0$
- B. $t = 3.06 \text{ s}$, $A = 0$
- C. $t = 1.529 \text{ s}$, $A = 49.1 \text{ N}$
- D. $t = 3.06 \text{ s}$, $A = 49.1 \text{ N}$

Answer: Option C

41.

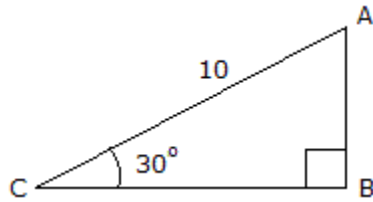

Using the basic trigonometric functions, determine the length of side AB of the right triangle.

- A. $h = 5.77$
- B. $h = 11.55$
- C. $h = 5$
- D. $h = 8.66$

Answer: Option C

42.

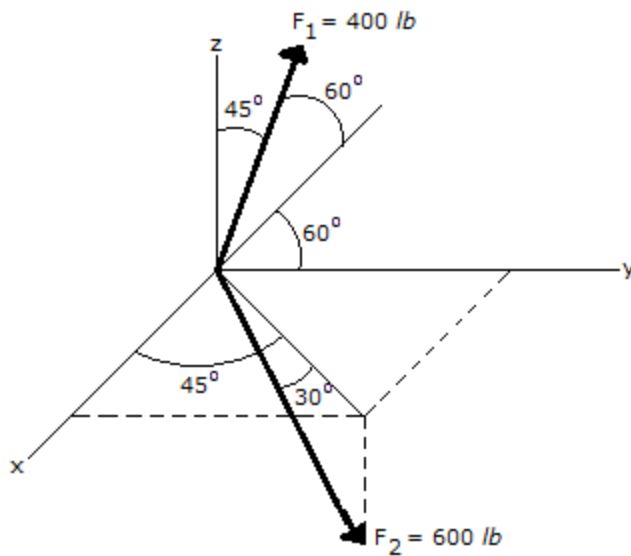

Express the Force F_2 in Cartesian vector form.

- A. $\mathbf{F}_2 = (155 \mathbf{i} + 155 \mathbf{j} + 300 \mathbf{k}) \text{ lb}$
- B. $\mathbf{F}_2 = (212 \mathbf{i} + 212 \mathbf{j} - 519 \mathbf{k}) \text{ lb}$
- C. $\mathbf{F}_2 = (155 \mathbf{i} + 155 \mathbf{j} - 300 \mathbf{k}) \text{ lb}$

- D. $\mathbf{F}_2 = (367 \mathbf{i} + 367 \mathbf{j} - 300 \mathbf{k}) \text{ lb}$

Answer: Option D

43.

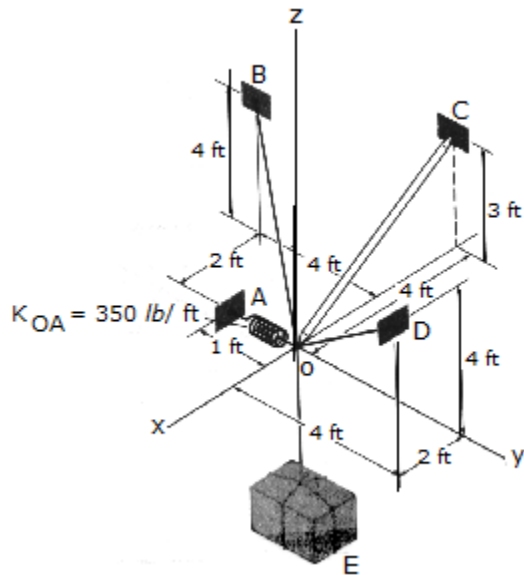

Determine the tension developed in cables OD and OB and the strut OC , required to support the 500-lb crate. The spring OA has an unstretched length of 0.2 ft and a stiffness of $k_{OA} = 350 \text{ lb/ft}$. The force in the strut acts along the axis of the strut.

- A. $F_{ob} = 289 \text{ lb}$, $F_{oc} = 175.0 \text{ lb}$, $F_{od} = 131.3 \text{ lb}$
- B. $F_{ob} = 86.2 \text{ lb}$, $F_{oc} = 175.0 \text{ lb}$, $F_{od} = 506 \text{ lb}$
- C. $F_{ob} = 375 \text{ lb}$, $F_{oc} = 0$, $F_{od} = 375 \text{ lb}$
- D. $F_{ob} = 664 \text{ lb}$, $F_{oc} = 175.0 \text{ lb}$, $F_{od} = 244 \text{ lb}$

Answer: Option B

44.

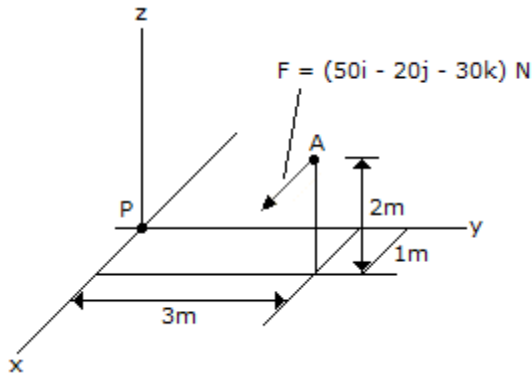

Replace the force at A by an equivalent force and couple moment at P . Express the results on Cartesian vector form.

- A. $\mathbf{F} = (-50\mathbf{i} + 20\mathbf{j} + 30\mathbf{k}) \text{ N}$, $\mathbf{M} = (50\mathbf{i} - 130\mathbf{j} + 170\mathbf{k}) \text{ N}\cdot\text{m}$
- B. $\mathbf{F} = (-50\mathbf{i} + 20\mathbf{j} + 30\mathbf{k}) \text{ N}$, $\mathbf{M} = (-50\mathbf{i} + 60\mathbf{j} + 60\mathbf{k}) \text{ N}\cdot\text{m}$
- C. $\mathbf{F} = (50\mathbf{i} - 20\mathbf{j} - 30\mathbf{k}) \text{ N}$, $\mathbf{M} = (-50\mathbf{i} + 130\mathbf{j} - 170\mathbf{k}) \text{ N}\cdot\text{m}$
- D. $\mathbf{F} = (50\mathbf{i} - 20\mathbf{j} - 30\mathbf{k}) \text{ N}$, $\mathbf{M} = (50\mathbf{i} - 60\mathbf{j} - 60\mathbf{k}) \text{ N}\cdot\text{m}$

Answer: Option C

45.

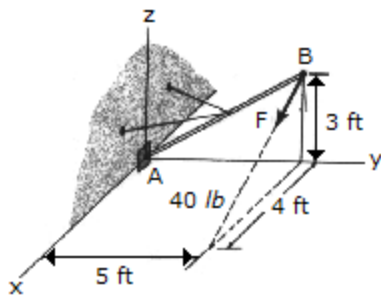

Replace the force \mathbf{F} , having a magnitude of $F = 40 \text{ lb}$ and acting at B , by an equivalent force and couple moment at A .

- A. $\mathbf{F} = (32\mathbf{i} - 24\mathbf{k}) \text{ lb}$, $\mathbf{M} = (-120\mathbf{i} + 96\mathbf{j} - 160\mathbf{k}) \text{ lb}\cdot\text{ft}$
- B. $\mathbf{F} = (32\mathbf{i} - 24\mathbf{k}) \text{ lb}$, $\mathbf{M} = 233\mathbf{k} \text{ lb}\cdot\text{ft}$
- C. $\mathbf{F} = (32\mathbf{i} - 24\mathbf{k}) \text{ lb}$, $\mathbf{M} = -72\mathbf{k} \text{ lb}\cdot\text{ft}$

- D. $\mathbf{F} = (32\mathbf{i}-24\mathbf{k})$ lb, $\mathbf{M} = (-120\mathbf{i}+160\mathbf{j}+40\mathbf{k})$ lb-ft

Answer: Option A

46.

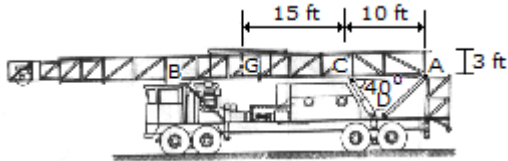

The oil rig is supported on the trailer by the pin or axle at *A* and the frame at *B*. If the rig has a weight of 115,000 lb and the center of gravity at *G*, determine the force *F* that must be developed along the hydraulic cylinder *CD* in order to start lifting the rig (slowly) off *B* toward the vertical. Also compute the horizontal and vertical components of reaction at the pin *A*.

- A. $A_x = 343$ kip, $A_y = -172.5$ kip, $F_{CD} = 447$ kip
- B. $A_x = 205$ kip, $A_y = -57.5$ kip, $F_{CD} = 268$ kip
- C. $A_x = 241$ kip, $A_y = -172.5$ kip, $F_{CD} = 375$ kip
- D. $A_x = 220$ kip, $A_y = -70.1$ kip, $F_{CD} = 288$ kip

Answer: Option A

47.

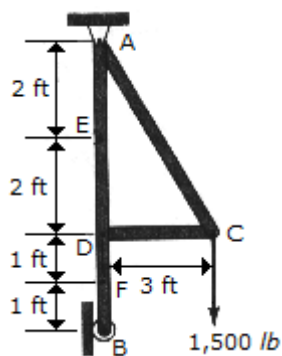

Determine the internal axial force, shear force, and moment at point *F* of the frame.

- A. $A_F = 0$, $V_F = 750$ lb, $M_F = 750$ lb-ft

- B. $A_F = 1500 \text{ lb}, V_F = 0, M_F = 4500 \text{ lb-ft}$
- C. $A_F = 0, V_F = 1500 \text{ lb}, M_F = 4500 \text{ lb-ft}$
- D. $A_F = 750 \text{ lb}, V_F = 0, M_F = 750 \text{ lb-ft}$

Answer: Option A

48.

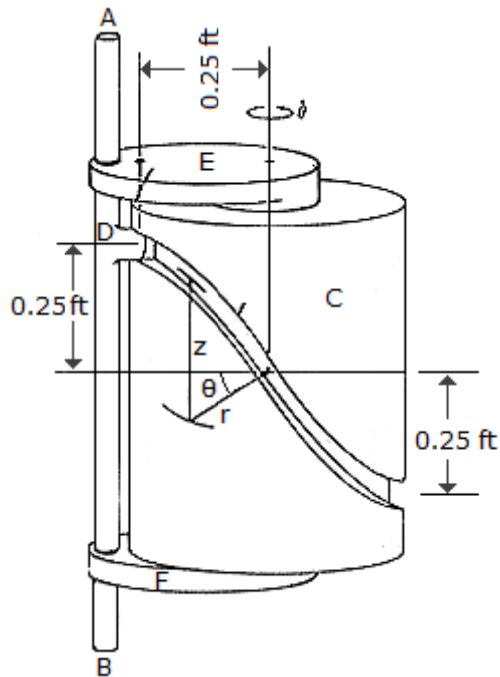

The cylindrical cam C is held fixed while the rod AB and bearings E and F rotate about the vertical axis of the cam at a constant rate of $\dot{\theta} = 4 \text{ rad/s}$. If the rod is free to slide through the bearings, determine the magnitudes of the velocity and acceleration of the guide D on the rod as a function of θ . The guide follows the groove in the cam, and the groove is defined by the equations $r = 0.25 \text{ ft}$ and $z = (0.25 \cos \theta) \text{ ft}$.

- A. $v = \sqrt{1 + \sin^2 \theta} \text{ ft/s}, a = 4.00 \sqrt{1 + \cos^2 \theta} \text{ ft/s}^2$
- B. $v = \cos \theta \text{ ft/s}, a = 4.00 \sin \theta \text{ ft/s}^2$
- C. $v = \sin \theta \text{ ft/s}, a = 4.00 \cos \theta \text{ ft/s}^2$

- D. $v = 1.000 \text{ ft/s}$, $a = 4.00 \text{ ft/s}^2$

Answer: Option A

49.

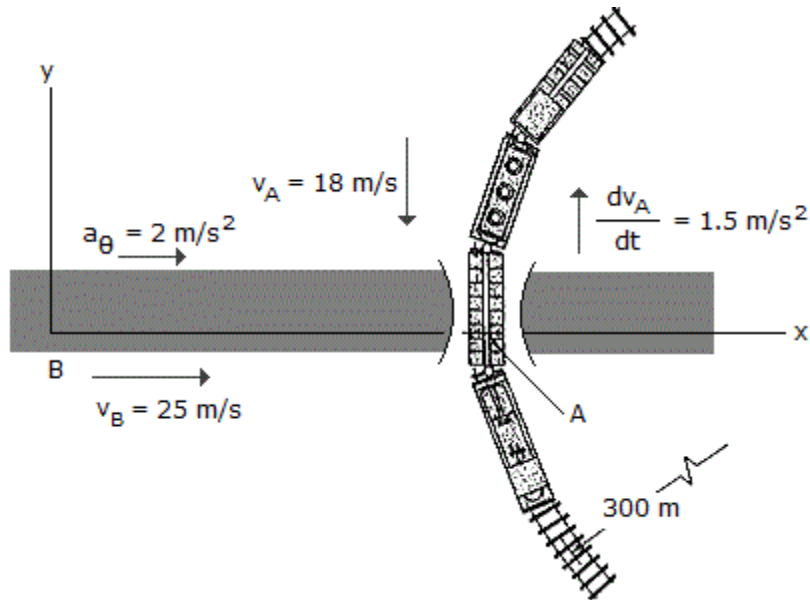

A passenger in the automobile B observes the motion of the train car A . At the instant shown, the train has a speed of 18 m/s and is reducing its speed at a rate of 1.5 m/s^2 . The automobile is accelerating at 2 m/s^2 and has a speed of 25 m/s . Determine the velocity and acceleration of A with respect to B . The train is moving along a curve of radius $= 300 \text{ m}$.

- A. $v_{A/B} = (25.0\mathbf{i} + 18.00\mathbf{j}) \text{ m/s}$, $a_{A/B} = (2.00\mathbf{i} - 1.500\mathbf{j}) \text{ m/s}^2$
- B. $v_{A/B} = (25.0\mathbf{i} + 18.00\mathbf{j}) \text{ m/s}$, $a_{A/B} = (0.920\mathbf{i} - 1.500\mathbf{j}) \text{ m/s}^2$
- C. $v_{A/B} = (-25.0\mathbf{i} - 18.00\mathbf{j}) \text{ m/s}$, $a_{A/B} = (-2.00\mathbf{i} + 1.500\mathbf{j}) \text{ m/s}^2$
- D. $v_{A/B} = (-25.0\mathbf{i} - 18.00\mathbf{j}) \text{ m/s}$, $a_{A/B} = (-0.920\mathbf{i} + 1.500\mathbf{j}) \text{ m/s}^2$

Answer: Option D

50.

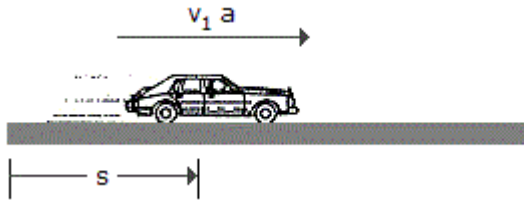

A car, initially at rest, moves along a straight road with constant acceleration such that it attains a velocity of 60 ft/s when $s = 150$ ft. Then after being subjected to *another* constant acceleration, it attains a final velocity of 100 ft/s when $s = 325$ ft. Determine the average velocity and average acceleration of the car for the entire 325-ft displacement.

- A. $v_{\text{avg}} = 80.0$ ft/s, $a_{\text{avg}} = 15.15$ ft/s²
- B. $v_{\text{avg}} = 45.2$ ft/s, $a_{\text{avg}} = 13.91$ ft/s²
- C. $v_{\text{avg}} = 80.0$ ft/s, $a_{\text{avg}} = 12.57$ ft/s²
- D. $v_{\text{avg}} = 55.0$ ft/s, $a_{\text{avg}} = 15.15$ ft/s²

Answer: Option B

51.

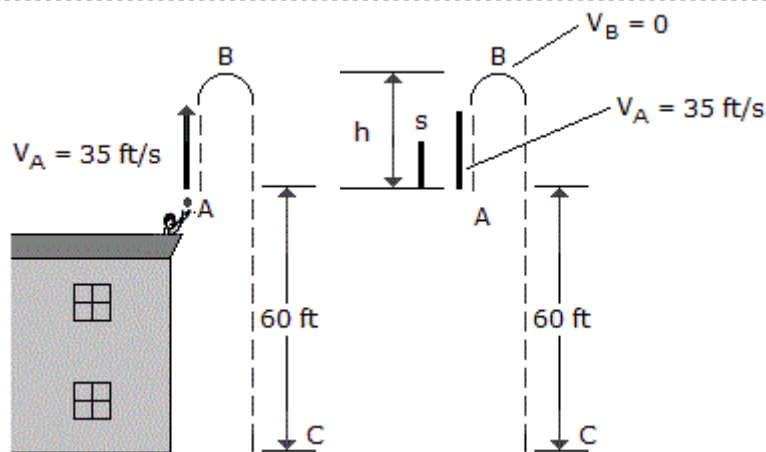

A ball thrown vertically upward from the top of a building with an initial velocity of $v_A = 35$ ft/s. Determine (a) how high above the top of the building the ball will go before it stops at B , (b) the time t_{AB} it takes to reach its maximum height, and (c) the total time t_{AC} needed for it to reach the ground at C from the instant it is released.

- A. $h = 62.4$ ft, $t_{AB} = 3.57$ s, $t_{AC} = 7.14$ s

- B. $h = 19.02 \text{ ft}$, $t_{AB} = 1.087 \text{ s}$, $t_{AC} = 2.17 \text{ s}$
- C. $h = 19.02 \text{ ft}$, $t_{AB} = 1.087 \text{ s}$, $t_{AC} = 3.30 \text{ s}$
- D. $h = 62.4 \text{ ft}$, $t_{AB} = 3.57 \text{ s}$, $t_{AC} = 8.56 \text{ s}$

Answer: Option C

52. A boat is traveling along a circular path having a radius of 20 m. Determine the magnitude of the boat's acceleration if at a given instant the boat's speed is $v = 5 \text{ m/s}$ and the rate of increase in speed is $\dot{v} = 2 \text{ m/s}^2$.

- A. $a = 2.00 \text{ m/s}^2$
- B. $a = 2.36 \text{ m/s}^2$
- C. $a = 1.25 \text{ m/s}^2$
- D. $a = 12.50 \text{ m/s}^2$

Answer: Option B

53.

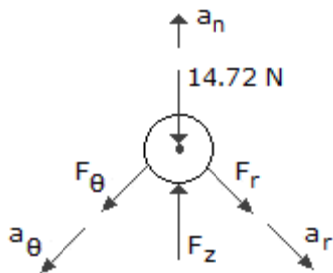

A particle having a mass of 1.5 kg, moves along a three-dimensional path defined by the equations $r = 94 + 3t$ m, $\theta = (t^2 + 2)$ rad, and $z = (6 - t^3)$ m, where t is in seconds, and the z -axis is vertical. Determine the r , θ , and z components of force which the path exerts on the particle when $t = 2$ s.

- A. $F_r = 0$, $F_\theta = 30 \text{ N}$, $F_z = -18.00 \text{ N}$
- B. $F_r = -240 \text{ N}$, $F_\theta = 66.0 \text{ N}$, $F_z = -3.29 \text{ N}$

- C. $F_r = 0, F_2 = 3 \text{ N}, F_z = -18.00 \text{ N}$
- D. $F_r = -160.0 \text{ N}, F_2 = 44.0 \text{ N}, F_z = -12.00 \text{ N}$

Answer: Option B

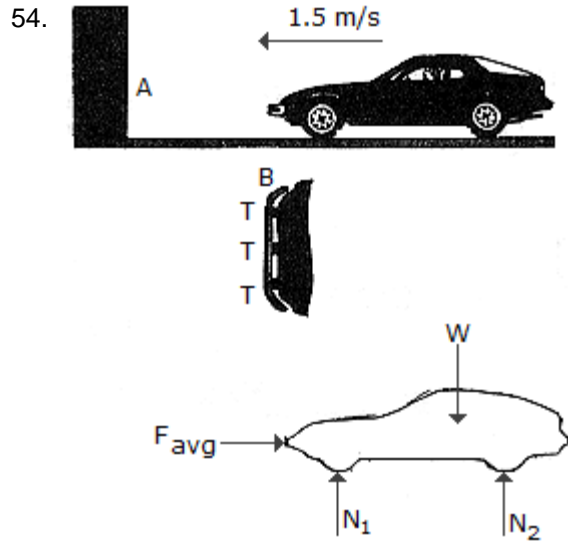

A car is equipped with a bumper B designed to absorb collisions. The bumper is mounted to the car using pieces of flexible tubing T . Upon collision with a rigid barrier A , a constant horizontal force \mathbf{F} is developed which causes a car deceleration of $3g = 29.43 \text{ m/s}^2$ (the highest safe deceleration for a passenger without a seatbelt). If the car and passenger have a total mass of 1.5 Mg and the car is initially coasting with a speed of 1.5 m/s , compute the magnitude of \mathbf{F} needed to stop the car and the deformation x of the bumper tubing.

- A. $F = 44.1 \text{ kN}, x = 38.2 \text{ mm}$
- B. $F = 22.1 \text{ kN}, x = 76.4 \text{ mm}$
- C. $F = 22.1 \text{ kN}, x = 38.2 \text{ mm}$
- D. $F = 44.1 \text{ kN}, x = 76.4 \text{ mm}$

Answer: Option A

55.

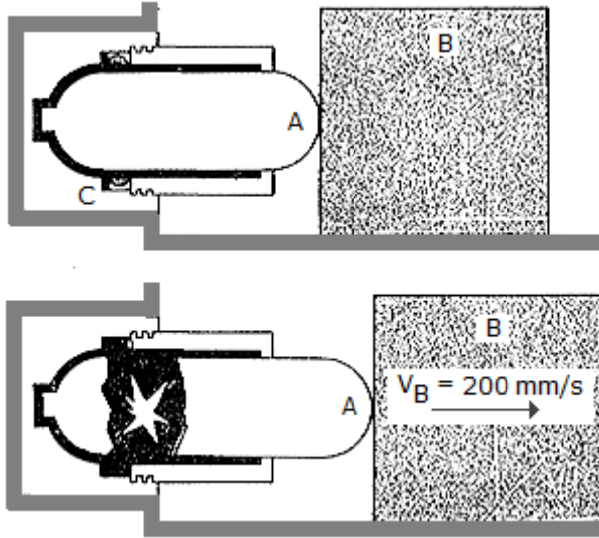

In cases of emergency, the gas actuator can be used to move a 75-kg block B by exploding a charge C near a pressurized cylinder of negligible mass. As a result of the explosion, the cylinder fractures and the released gas forces the front part of the cylinder, A , to move B and the floor is $\mu = 0.5$, determine the impulse that the actuator must impart to B .

- A. Imp = 147.2 N-s
- B. Imp = 132.2 N-s
- C. Imp = 15.00 N-s
- D. Imp = 162.2 N-s

Answer: Option D

56.

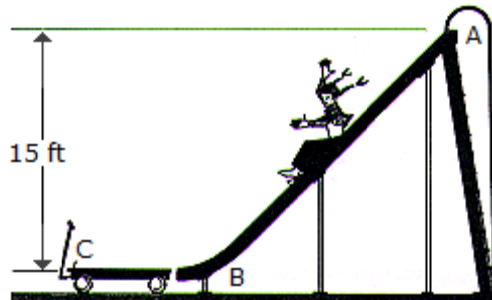

A girl having a weight of 40 lb slides down the smooth slide onto the surface of a 20-lb wagon. Determine the speed of the wagon at the instant the girl stops sliding on it. If someone ties the wagon to the slide at B , determine the horizontal impulse the girl will exert at C in order to stop her motion. Neglect friction and assume that the girl starts from rest at the top of the slide, A .

- A. $v_{\text{wagon}} = 20.7 \text{ ft/s}$ Imp = 38.6 lb-s
- B. $v_{\text{wagon}} = 31.1 \text{ ft/s}$ Imp = 38.6 lb-s
- C. $v_{\text{wagon}} = 31.1 \text{ ft/s}$ Imp = 57.9 lb-s
- D. $v_{\text{wagon}} = 20.7 \text{ ft/s}$ Imp = 57.9 lb-s

Answer: Option A

57. $v = 6 \text{ in./s}$

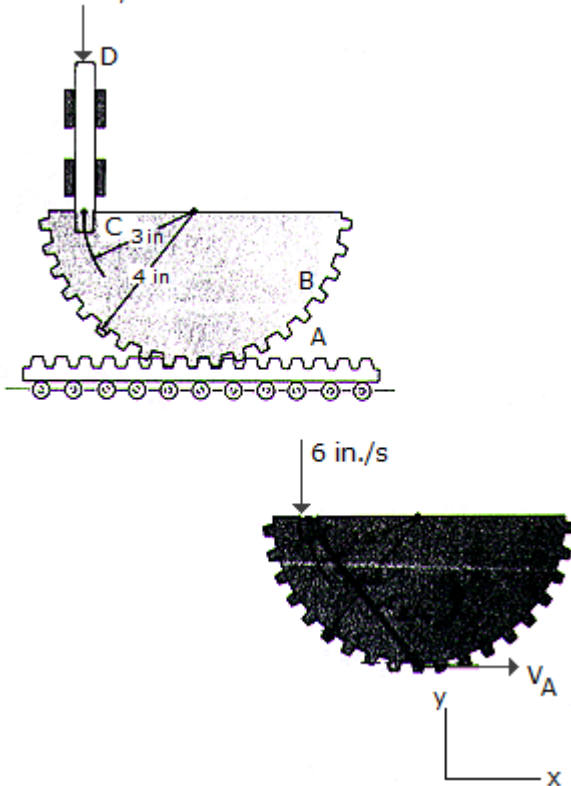

If rod CD has a downward velocity of 6 in/s at the instant shown, determine the velocity of the gear rack A at this instant. The rod is pinned at C to gear B .

- A. $v_A = 6.00 \text{ in./s}$
- B. $v_A = 8.00 \text{ in./s}$

- C. $v_A = 4.50 \text{ in./s}$
- D. $v_A = 3.38 \text{ in./s}$

Answer: Option B

58.

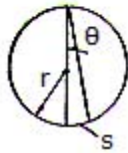
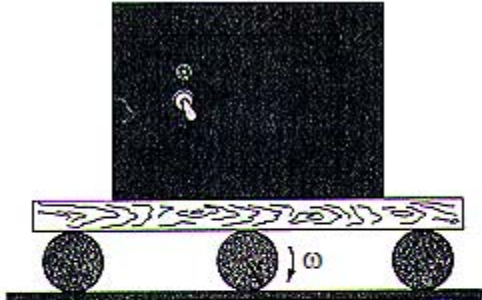

The safe is transported on a platform which rests on rollers, each having a radius r . If the rollers do not slip, determine their angular velocity ω if the safe moves forward with a velocity v .

- A. $\omega = v/(2r)$
- B. $\omega = v/r$
- C. $\omega = 3v/r$
- D. $\omega = 2v/r$

Answer: Option A

59.

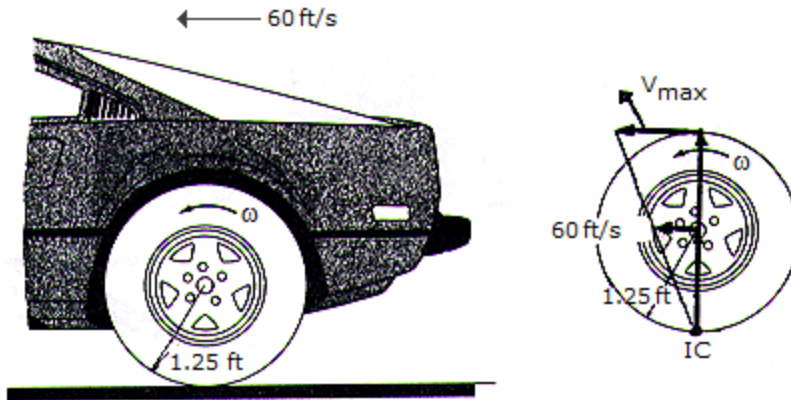

The automobile with wheels 2.5 ft in diameter is traveling in a straight path at a rate of 60 ft/s. If no slipping occurs, determine the angular velocity of one of the rear wheels and the velocity of the fastest moving point on the wheel.

- A. $\omega = 48 \text{ rad/s}$, $v_{max} = 84.9 \text{ ft/s}$
- B. $\omega = 24 \text{ rad/s}$, $v_{max} = 84.9 \text{ ft/s}$
- C. $\omega = 48 \text{ rad/s}$, $v_{max} = 120.0 \text{ ft/s}$
- D. $\omega = 24 \text{ rad/s}$, $v_{max} = 120.0 \text{ ft/s}$

Answer: Option C

60.

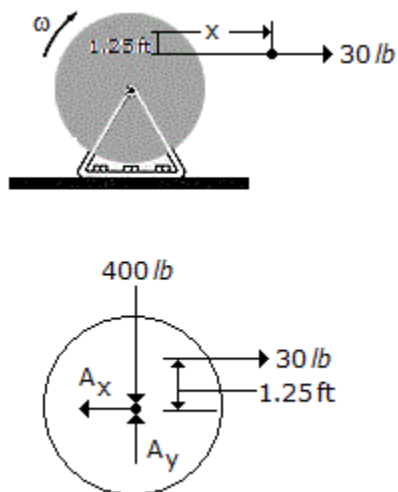

A cord wrapped around the inner core of a spool. If the cord is pulled with a constant tension of 30 lb and the spool is originally at rest, determine the spool's angular Velocity when $s = 8$ ft of cord have unraveled. Neglect the weight of the cord. The spool and cord have a total weight of 400 lb and the

radius of gyration about the axle A is $k_A = 1.30$ ft.

- A. $\omega = 6.73$ rad/s
- B. $\omega = 3.38$ rad/s
- C. $\omega = 4.78$ rad/s
- D. $\omega = 11.43$ rad/s

Answer: Option C
